

## CSMC 412

# Operating Systems Prof. Ashok K Agrawala

© 2004 Ashok Agrawala  
Set 9

## Memory Management

- Background
- Swapping
- Contiguous Allocation
- Paging
- Segmentation
- Segmentation with Paging

## Background

- Program must be brought into memory and placed within a process for it to be run.
- *Input queue* – collection of processes on the disk that are waiting to be brought into memory to run the program.
- User programs go through several steps before being run.

## Binding of Instructions and Data to Memory

Address binding of instructions and data to memory addresses can happen at three different stages.

- **Compile time:** If memory location known a priori, absolute code can be generated; must recompile code if starting location changes.
- **Load time:** Must generate *relocatable* code if memory location is not known at compile time.
- **Execution time:** Binding delayed until run time if the process can be moved during its execution from one memory segment to another. Need hardware support for address maps (e.g., *base* and *limit registers*).

## Multistep Processing of a User Program

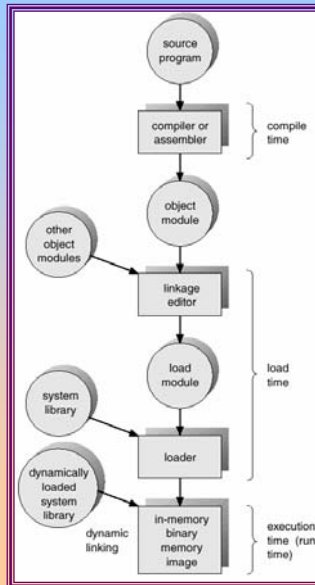

Operating System Concepts

9.5

## Logical vs. Physical Address Space

- The concept of a logical *address space* that is bound to a separate *physical address space* is central to proper memory management.
  - ☞ *Logical address* – generated by the CPU; also referred to as *virtual address*.
  - ☞ *Physical address* – address seen by the memory unit.
- Logical and physical addresses are the same in compile-time and load-time address-binding schemes; logical (virtual) and physical addresses differ in execution-time address-binding scheme.

Operating System Concepts

9.6

## Memory-Management Unit (MMU)

- Hardware device that maps virtual to physical address.
- In MMU scheme, the value in the relocation register is added to every address generated by a user process at the time it is sent to memory.
- The user program deals with *logical* addresses; it never sees the *real* physical addresses.

## Dynamic relocation using a relocation register

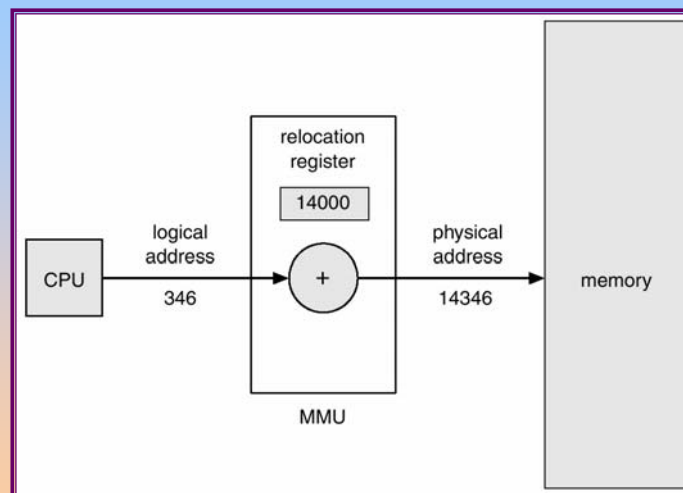

## Dynamic Loading

- Routine is not loaded until it is called
- Better memory-space utilization; unused routine is never loaded.
- Useful when large amounts of code are needed to handle infrequently occurring cases.
- No special support from the operating system is required implemented through program design.

## Dynamic Linking

- Linking postponed until execution time.
- Small piece of code, *stub*, used to locate the appropriate memory-resident library routine.
- Stub replaces itself with the address of the routine, and executes the routine.
- Operating system needed to check if routine is in processes' memory address.
- Dynamic linking is particularly useful for libraries.

## Overlays

- Keep in memory only those instructions and data that are needed at any given time.
- Needed when process is larger than amount of memory allocated to it.
- Implemented by user, no special support needed from operating system, programming design of overlay structure is complex

## Overlays for a Two-Pass Assembler

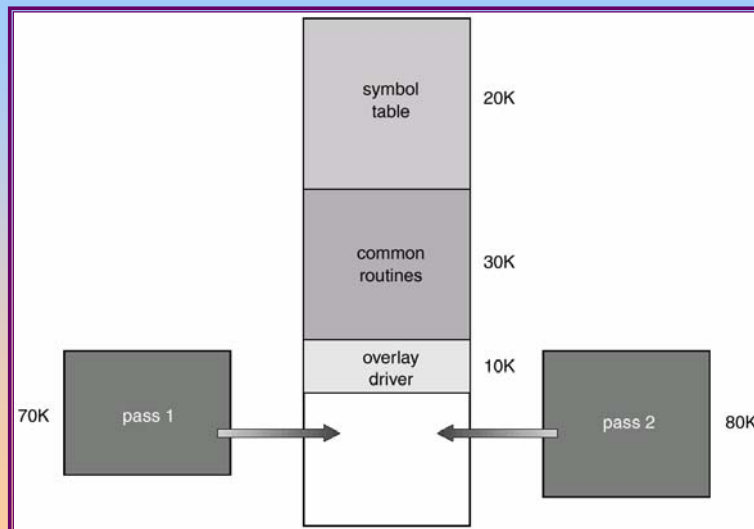

## Swapping

- A process can be *swapped* temporarily out of memory to a *backing store*, and then brought back into memory for continued execution.
- Backing store – fast disk large enough to accommodate copies of all memory images for all users; must provide direct access to these memory images.
- *Roll out, roll in* – swapping variant used for priority-based scheduling algorithms; lower-priority process is swapped out so higher-priority process can be loaded and executed.
- Major part of swap time is transfer time; total transfer time is directly proportional to the *amount* of memory swapped.
- Modified versions of swapping are found on many systems, i.e., UNIX, Linux, and Windows.

## Schematic View of Swapping

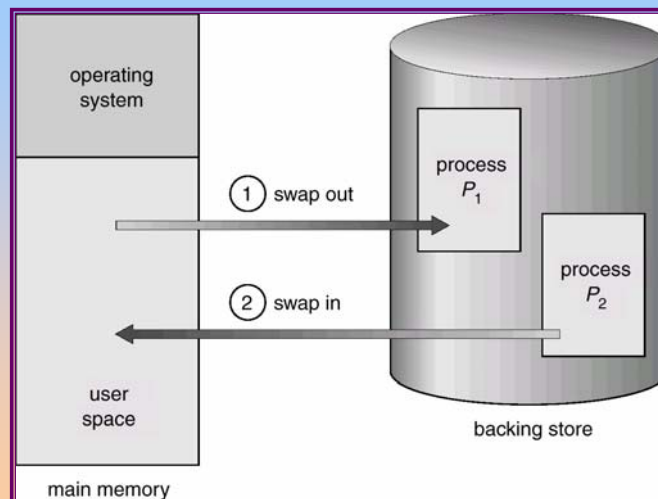

## Contiguous Allocation

- Main memory usually into two partitions:
  - Resident operating system, usually held in low memory with interrupt vector.
  - User processes then held in high memory.
- Single-partition allocation
  - Relocation-register scheme used to protect user processes from each other, and from changing operating-system code and data.
  - Relocation register contains value of smallest physical address; limit register contains range of logical addresses – each logical address must be less than the limit register.

## Hardware Support for Relocation and Limit Registers

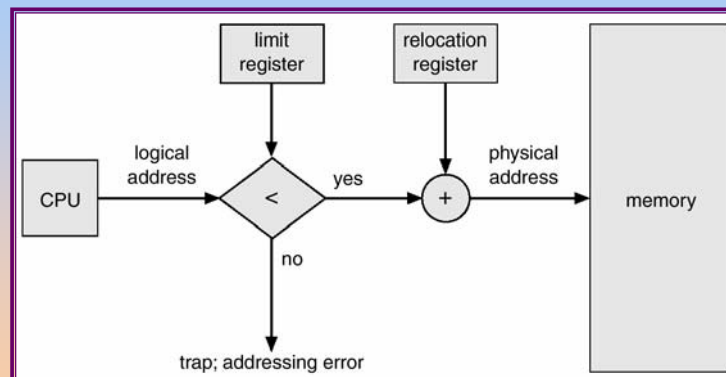

## Contiguous Allocation (Cont.)

- Multiple-partition allocation
  - *Hole* – block of available memory; holes of various size are scattered throughout memory.
  - When a process arrives, it is allocated memory from a hole large enough to accommodate it.
  - Operating system maintains information about:
    - a) allocated partitions
    - b) free partitions (hole)

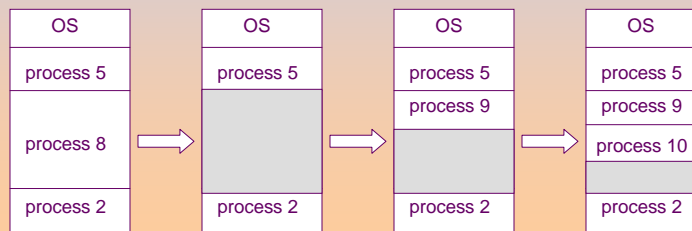

Operating System Concepts

9.17

## Dynamic Storage-Allocation Problem

How to satisfy a request of size  $n$  from a list of free holes.

- **First-fit:** Allocate the *first* hole that is big enough.
- **Best-fit:** Allocate the *smallest* hole that is big enough; must search entire list, unless ordered by size. Produces the smallest leftover hole.
- **Worst-fit:** Allocate the *largest* hole; must also search entire list. Produces the largest leftover hole.

First-fit and best-fit better than worst-fit in terms of speed and storage utilization.

Operating System Concepts

9.18

## Fragmentation

- **External Fragmentation** – total memory space exists to satisfy a request, but it is not contiguous.
- **Internal Fragmentation** – allocated memory may be slightly larger than requested memory; this size difference is memory internal to a partition, but not being used.
- Reduce external fragmentation by compaction
  - Shuffle memory contents to place all free memory together in one large block.
  - Compaction is possible *only* if relocation is dynamic, and is done at execution time.
  - I/O problem
    - Latch job in memory while it is involved in I/O.
    - Do I/O only into OS buffers.

## Paging

- Logical address space of a process can be noncontiguous; process is allocated physical memory whenever the latter is available.
- Divide physical memory into fixed-sized blocks called **frames** (size is power of 2, between 512 bytes and 8192 bytes).
- Divide logical memory into blocks of same size called **pages**.
- Keep track of all free frames.
- To run a program of size  $n$  pages, need to find  $n$  free frames and load program.
- Set up a page table to translate logical to physical addresses.
- Internal fragmentation.

## Address Translation Scheme

- Address generated by CPU is divided into:
  - ↪ *Page number (p)* – used as an index into a *page table* which contains base address of each page in physical memory.
  - ↪ *Page offset (d)* – combined with base address to define the physical memory address that is sent to the memory unit.

## Address Translation Architecture

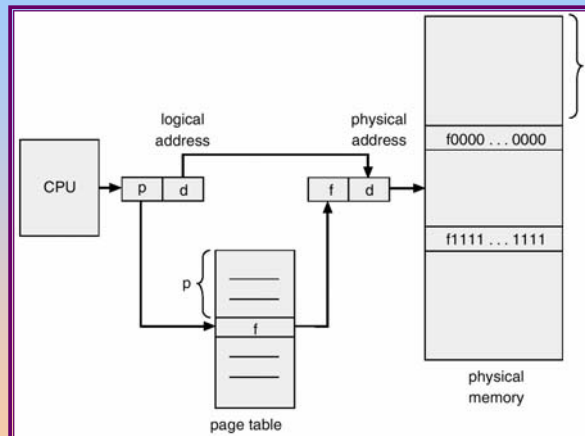

## Paging Example

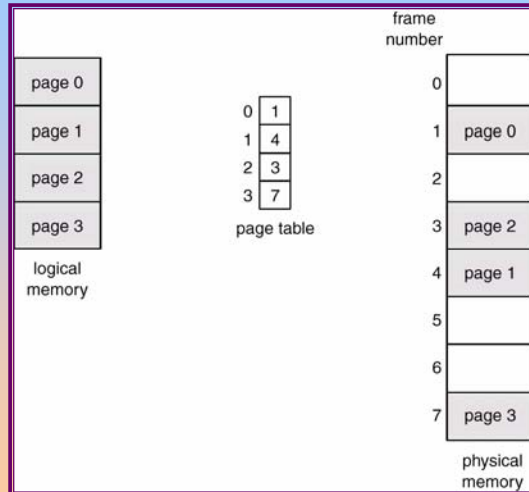

## Paging Example

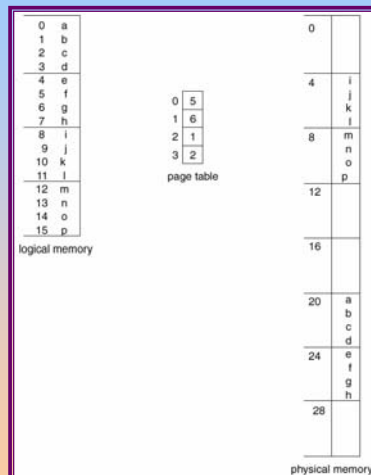

## Free Frames

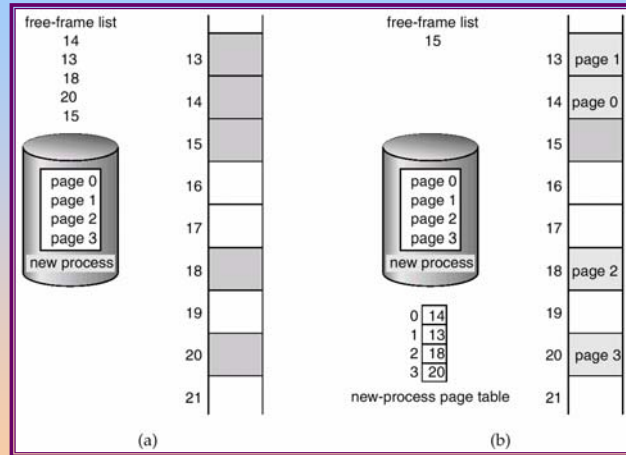

Before allocation

After allocation

## Implementation of Page Table

- Page table is kept in main memory.
- *Page-table base register (PTBR)* points to the page table.
- *Page-table length register (PRLR)* indicates size of the page table.
- In this scheme every data/instruction access requires two memory accesses. One for the page table and one for the data/instruction.
- The two memory access problem can be solved by the use of a special fast-lookup hardware cache called *associative memory* or *translation look-aside buffers (TLBs)*

## Associative Memory

### ■ Associative memory – parallel search

Page #	Frame #

Address translation ( $A'$ ,  $A''$ )

- ↪ If  $A'$  is in associative register, get frame # out.
- ↪ Otherwise get frame # from page table in memory

## Paging Hardware With TLB

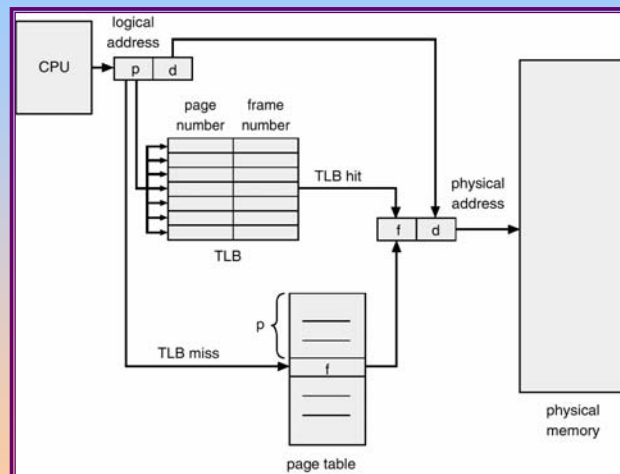

## Effective Access Time

- Associative Lookup =  $\epsilon$  time unit
- Assume memory cycle time is 1 microsecond
- Hit ratio – percentage of times that a page number is found in the associative registers; ration related to number of associative registers.
- Hit ratio =  $\alpha$
- Effective Access Time (EAT)

$$\begin{aligned} \text{EAT} &= (1 + \epsilon) \alpha + (2 + \epsilon)(1 - \alpha) \\ &= 2 + \epsilon - \alpha \end{aligned}$$

## Memory Protection

- Memory protection implemented by associating protection bit with each frame.
- *Valid-invalid* bit attached to each entry in the page table:
  - “valid” indicates that the associated page is in the process’ logical address space, and is thus a legal page.
  - “invalid” indicates that the page is not in the process’ logical address space.

## Valid (v) or Invalid (i) Bit In A Page Table

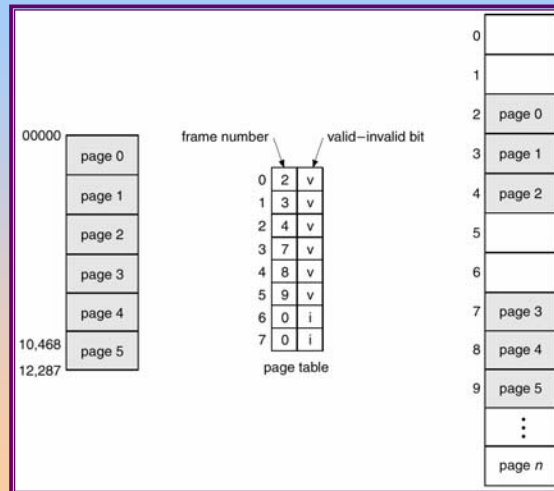

## Page Table Structure

- Hierarchical Paging
- Hashed Page Tables
- Inverted Page Tables

## Hierarchical Page Tables

- Break up the logical address space into multiple page tables.
- A simple technique is a two-level page table.

## Two-Level Paging Example

- A logical address (on 32-bit machine with 4K page size) is divided into:
  - ↪ a page number consisting of 20 bits.
  - ↪ a page offset consisting of 12 bits.
- Since the page table is paged, the page number is further divided into:
  - ↪ a 10-bit page number.
  - ↪ a 10-bit page offset.
- Thus, a logical address is as follows:

page number		page offset
$p_1$	$p_2$	$d$
10	10	12

where  $p_1$  is an index into the outer page table, and  $p_2$  is the displacement within the page of the outer page table.

## Two-Level Page-Table Scheme

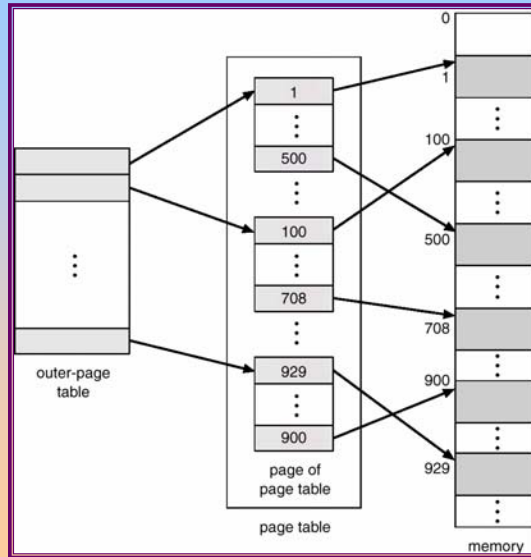

## Address-Translation Scheme

- Address-translation scheme for a two-level 32-bit paging architecture

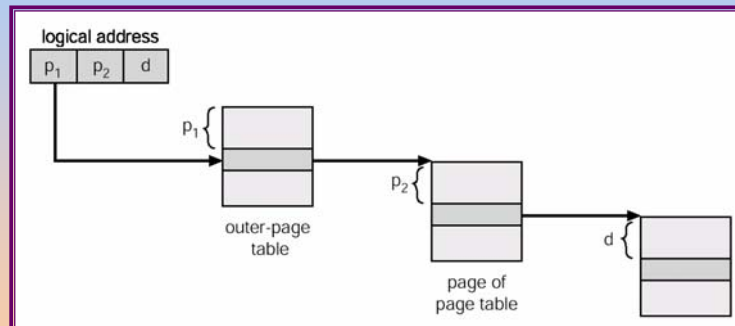

## Hashed Page Tables

- Common in address spaces > 32 bits.
- The virtual page number is hashed into a page table. This page table contains a chain of elements hashing to the same location.
- Virtual page numbers are compared in this chain searching for a match. If a match is found, the corresponding physical frame is extracted.

## Hashed Page Table

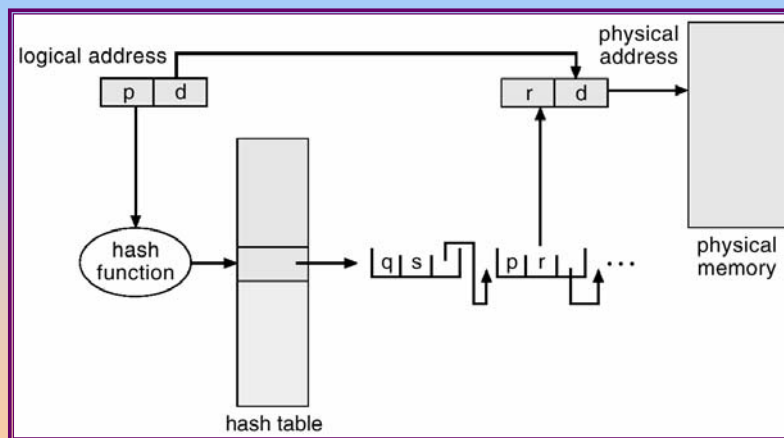

## Inverted Page Table

- One entry for each real page of memory.
- Entry consists of the virtual address of the page stored in that real memory location, with information about the process that owns that page.
- Decreases memory needed to store each page table, but increases time needed to search the table when a page reference occurs.
- Use hash table to limit the search to one — or at most a few — page-table entries.

## Inverted Page Table Architecture

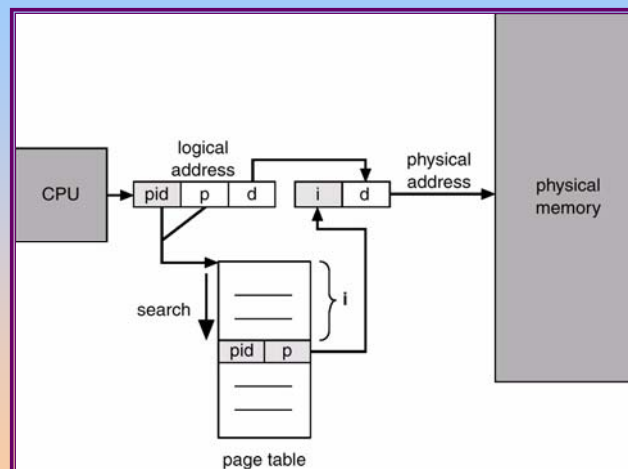

## Shared Pages

- Shared code
  - One copy of read-only (reentrant) code shared among processes (i.e., text editors, compilers, window systems).
  - Shared code must appear in same location in the logical address space of all processes.
  
- Private code and data
  - Each process keeps a separate copy of the code and data.
  - The pages for the private code and data can appear anywhere in the logical address space.

## Shared Pages Example

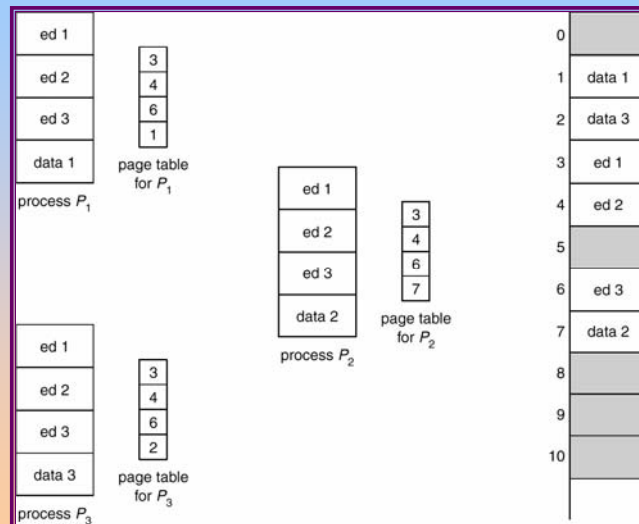

## Segmentation

- Memory-management scheme that supports user view of memory.
- A program is a collection of segments. A segment is a logical unit such as:
  - main program,
  - procedure,
  - function,
  - method,
  - object,
  - local variables, global variables,
  - common block,
  - stack,
  - symbol table, arrays

## User's View of a Program

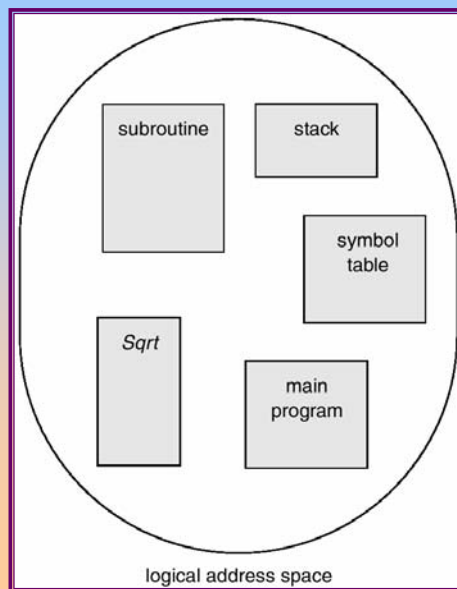

## Logical View of Segmentation

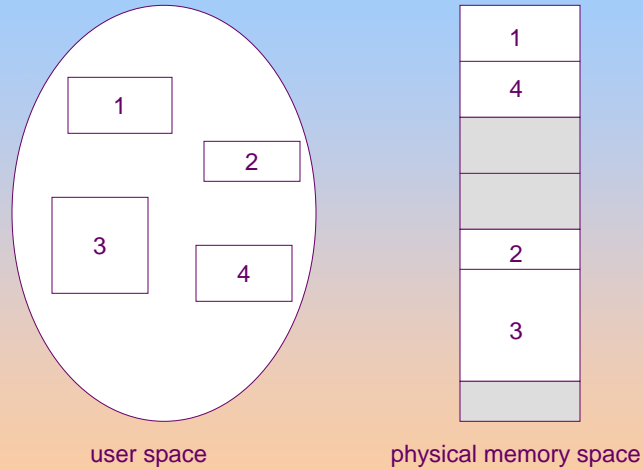

Operating System Concepts

9.45

## Segmentation Architecture

- Logical address consists of a two tuple:  
 $\langle \text{segment-number}, \text{offset} \rangle$ ,
- *Segment table* – maps two-dimensional physical addresses; each table entry has:
  - ↗ *base* – contains the starting physical address where the segments reside in memory.
  - ↗ *limit* – specifies the length of the segment.
- *Segment-table base register (STBR)* points to the segment table's location in memory.
- *Segment-table length register (STLR)* indicates number of segments used by a program;  
segment number  $s$  is legal if  $s < \text{STLR}$ .

Operating System Concepts

9.46

## Segmentation Architecture (Cont.)

- Relocation.
  - ☞ dynamic
  - ☞ by segment table
- Sharing.
  - ☞ shared segments
  - ☞ same segment number
- Allocation.
  - ☞ first fit/best fit
  - ☞ external fragmentation

## Segmentation Architecture (Cont.)

- Protection. With each entry in segment table associate:
  - ☞ validation bit = 0  $\Rightarrow$  illegal segment
  - ☞ read/write/execute privileges
- Protection bits associated with segments; code sharing occurs at segment level.
- Since segments vary in length, memory allocation is a dynamic storage-allocation problem.
- A segmentation example is shown in the following diagram

## Segmentation Hardware

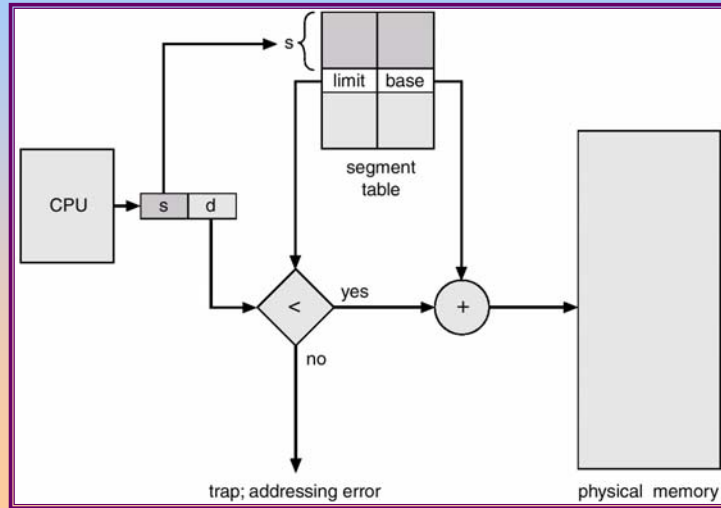

Operating System Concepts

9.49

## Example of Segmentation

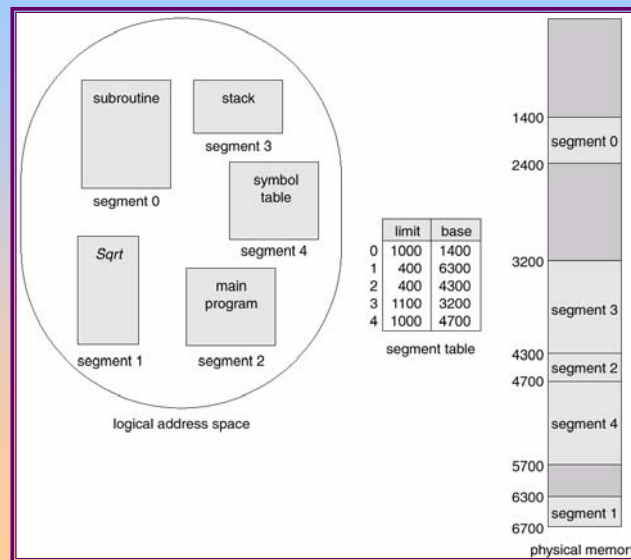

Operating System Concepts

9.50

## Sharing of Segments

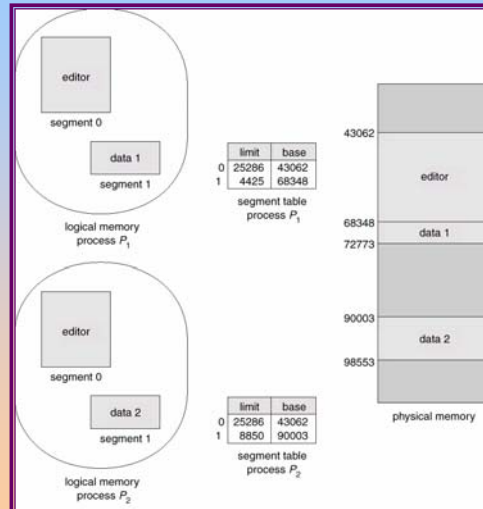

## Segmentation with Paging – MULTICS

- The MULTICS system solved problems of external fragmentation and lengthy search times by paging the segments.
- Solution differs from pure segmentation in that the segment-table entry contains not the base address of the segment, but rather the base address of a *page table* for this segment.

## MULTICS Address Translation Scheme

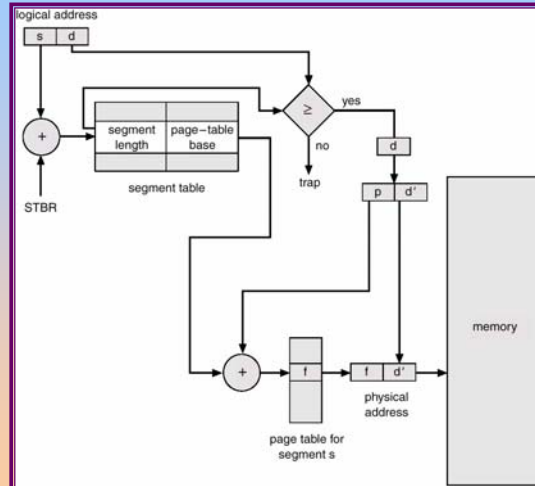

Operating System Concepts

9.53

## Segmentation with Paging – Intel 386

- As shown in the following diagram, the Intel 386 uses segmentation with paging for memory management with a two-level paging scheme.

Operating System Concepts

9.54

## Intel 30386 Address Translation

