

Questions?

- Project?

Ideation

“The best way to get a good idea is to get a lot of ideas”

- Seed the brainstorm
- Get physical
- Follow the rules (IDEO)
 - One conversation at a time
 - Stay focus
 - Encourage wild ideas
 - Defer judgment
 - Build upon idea from others

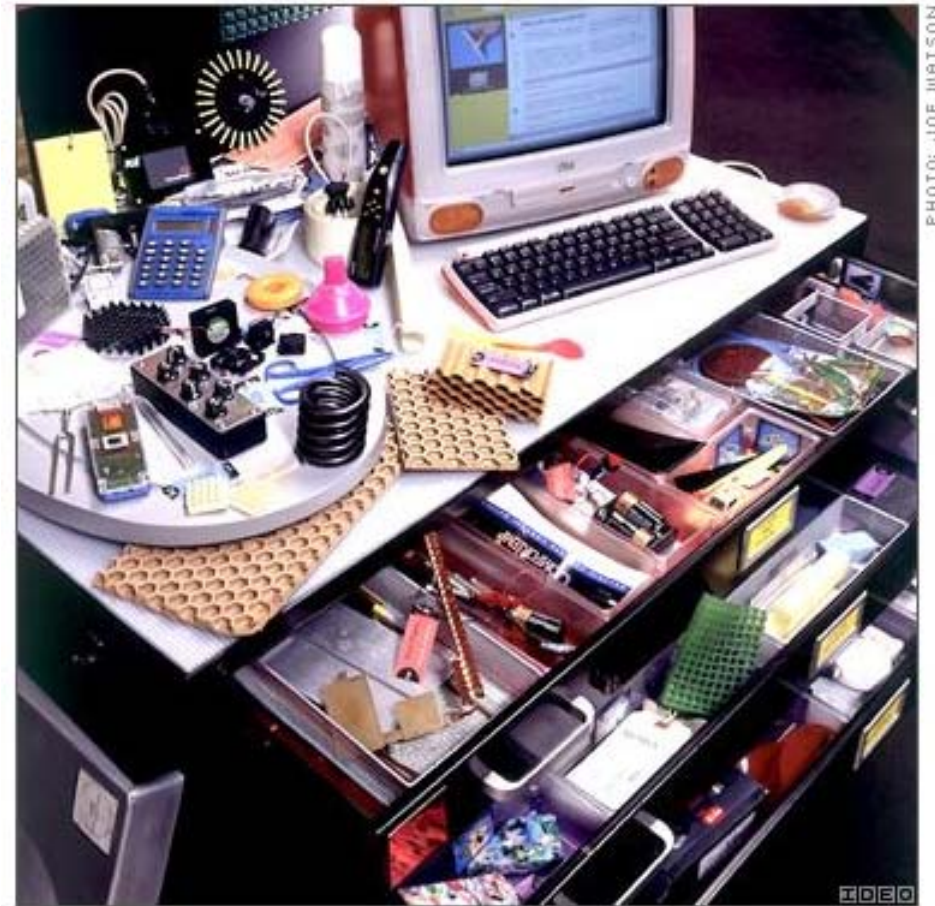

Idea selection

- Literature search, previous work and patent
 - Well documented report of previous experiences
- Looking around to see how others solved similar problem
 - In everyday life
 - By putting things apart
- Be aware of Intellectual property rights
 - Patents
 - Trademarks
 - Copyrights

Deconstruction

- Safety is always the most important consideration
 - Wear safety glasses!
 - If there is a warning about dangerous content: Don't open it!
 - Be mindful of sharp tools and parts!
 - Predict the outcome of your action before carrying them!
 - *Things might snap, pinch...*
 - Always put safety first
 - *If it does not feel right don't do it...*
- Document
 - Location of screws, orientation of connectors...
 - Sketches assemblies
 - Take pictures

Molded part

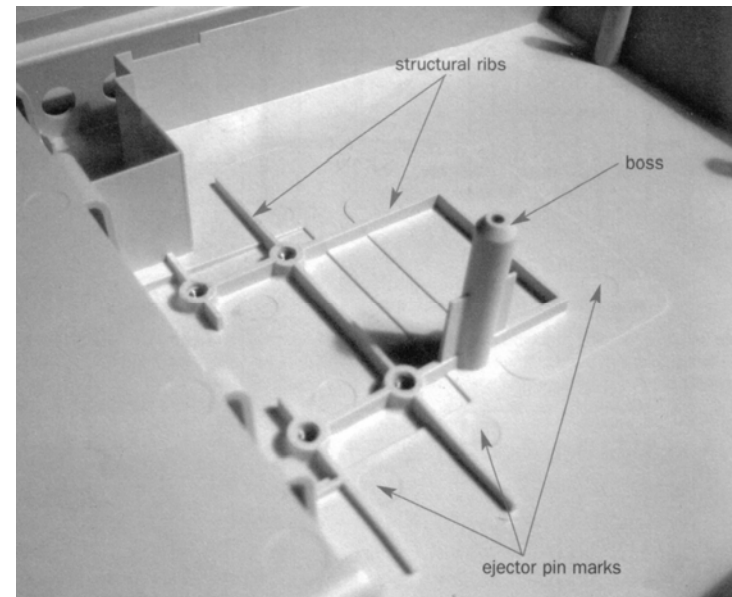
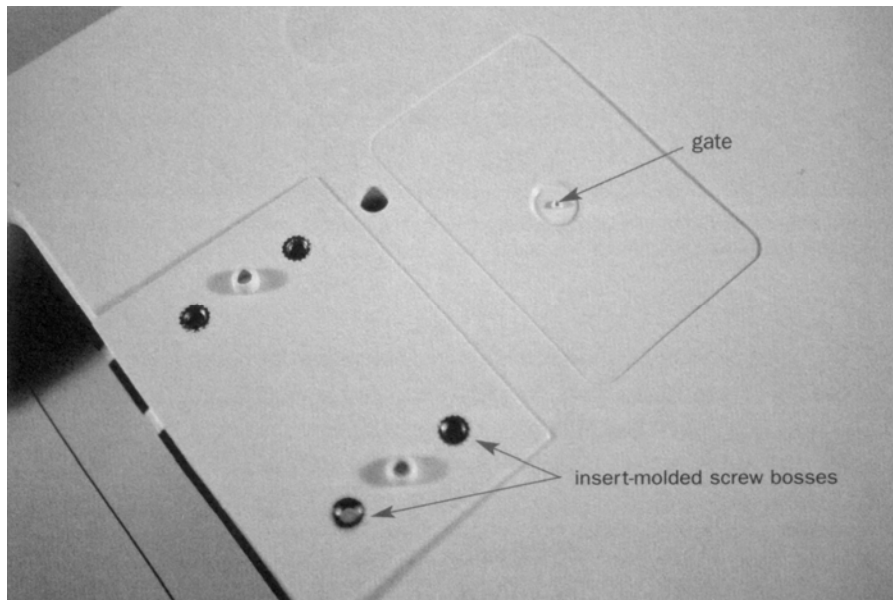
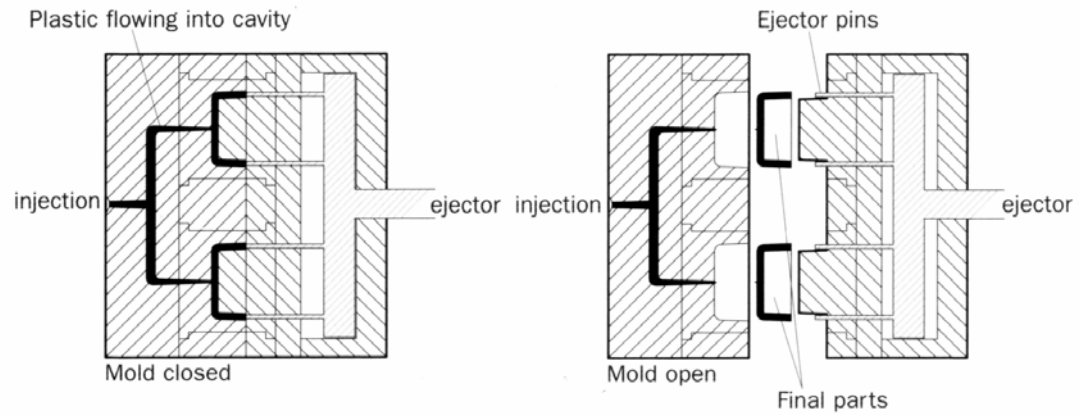

From "Process Material Measurements", Cuffaro et al.

Fasteners

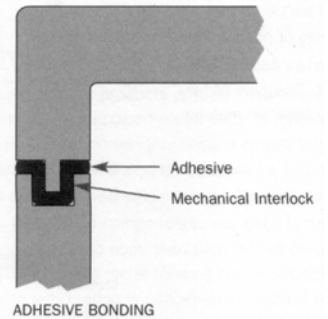
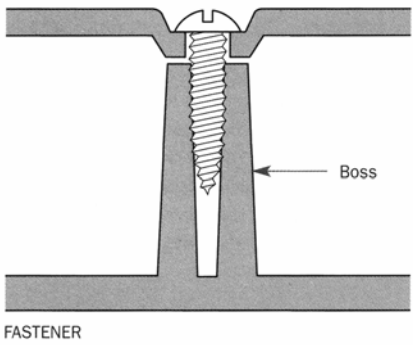
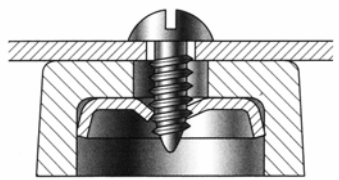
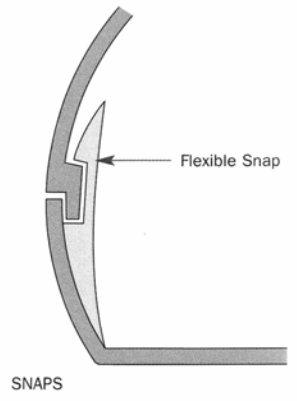
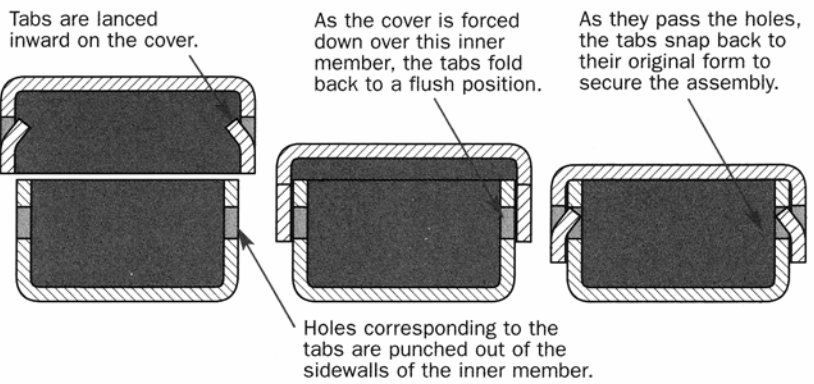
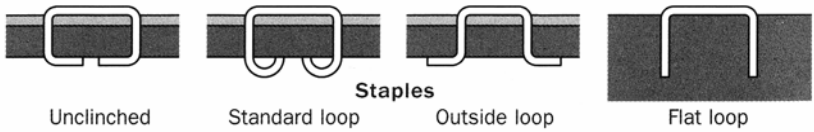

From "Process Material Measurements", Cuffaro et al.

What to look for

- Assembly techniques
- Mechanisms
- Architecture
- ...