

# CMSC330 Example Quiz #1 Solution

1. (6 pts) Programming languages

Name a disadvantage of dynamic types in terms of program correctness. Provide a code example in Ruby showing the disadvantage.

**Type errors are not caught at compile time.**

**For example, in the following code:**

```
x = 4
x = "a" if ( ... )
x = x / 2
```

**x = "a" is not a compile-time error. The error is hidden until x = x/2 is executed at run time.**

2. (4 pts) Ruby features

What is the output (if any) of the following Ruby programs? Write FAIL if code does not execute.

```
a. a = [ ]                                // nil b 3
   a[1] = "b"
   a[2] = 3
   a.each{ |x| puts x }
```

3. (4 pts) Regular expressions and finite automata

Give a regular expression equivalent to the following finite automaton.

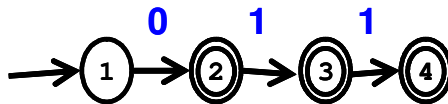

**0|01|011 or 0(ε|1|11)**

4. (6 pts) Regular expression to NFA

Create a NFA for the regular expression  $a(bc)^*$  using construction method from class.

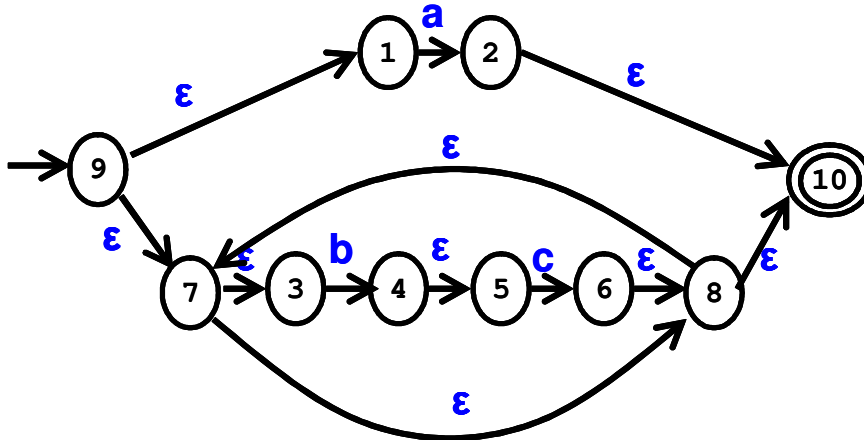

5. (10 pts) NFA to DFA

Apply the subset construction algorithm to convert the following NFA to a DFA. Be sure to list the NFA states represented by each DFA state.

