

CSMC 417

Computer Networks Prof. Ashok K Agrawala

© 2011 Ashok Agrawala
Set 3

The Physical Layer

Chapter 2

- Theoretical Basis for Data Communications
- Guided Transmission Media
- Wireless Transmission
- Communication Satellites
- Digital Modulation and Multiplexing
- Public Switched Telephone Network
- Mobile Telephone System
- Cable Television

Revised: August 2011

The Physical Layer

Foundation on which other layers build

- Properties of wires, fiber, wireless limit what the network can do

Key problem is to send (digital) bits using only (analog) signals

- This is called modulation

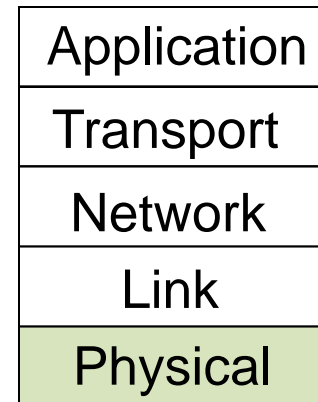

Theoretical Basis for Data Communication

- Fourier analysis »
- Bandwidth-limited signals »
- Maximum data rate of a channel »

Fourier Analysis

- We model the behavior of variation of voltage or current with mathematical functions
- Fourier series is used

$$g(t) = \frac{1}{2}c + \sum_{n=1}^{\infty} a_n \sin(2\pi nft) + \sum_{n=1}^{\infty} b_n \cos(2\pi nft)$$

- Function reconstructed with

$$a_n = \frac{2}{T} \int_0^T g(t) \sin(2\pi nft) dt \quad b_n = \frac{2}{T} \int_0^T g(t) \cos(2\pi nft) dt \quad c = \frac{2}{T} \int_0^T g(t) dt$$

Fourier Analysis

- A time-varying signal can be equivalently represented as a series of frequency components (harmonics):

$$g(t) = \frac{1}{2}c + \sum_{n=1}^{\infty} a_n \sin(2\pi nft) + \sum_{n=1}^{\infty} b_n \cos(2\pi nft)$$

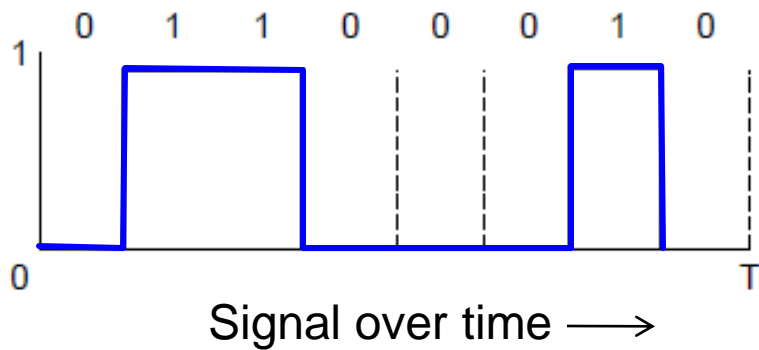

=

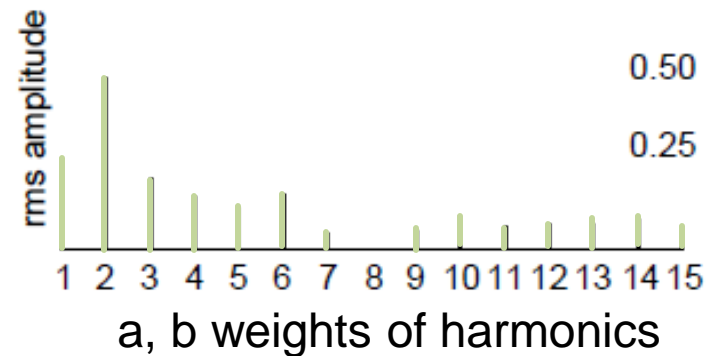

Bandwidth-Limited Signals

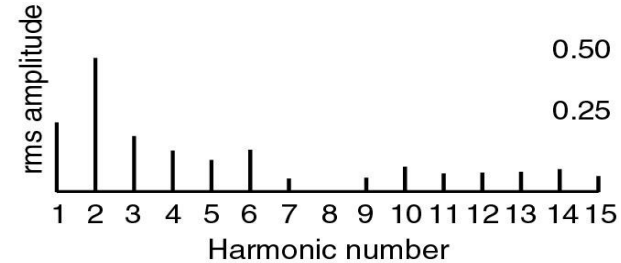
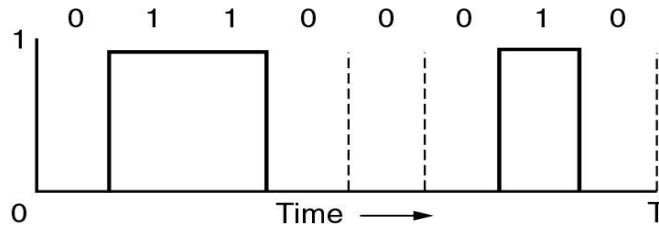

(a)

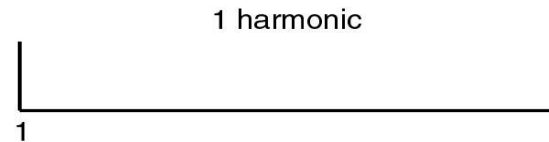
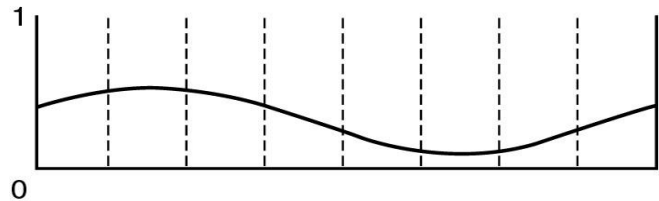

(b)

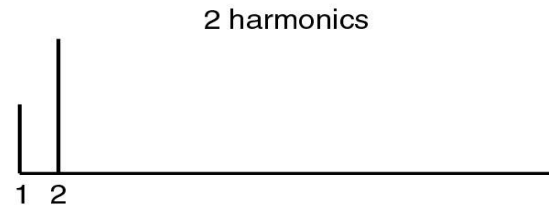
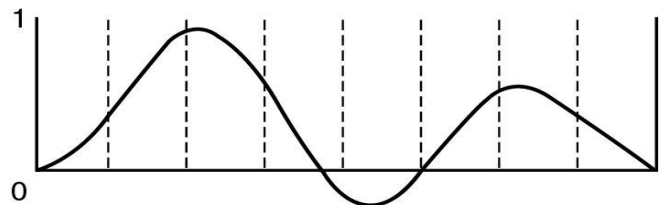

(c)

A binary signal and its root-mean-square Fourier amplitudes.
(b) – (c) Successive approximations to the original signal.

Bandwidth-Limited Signals

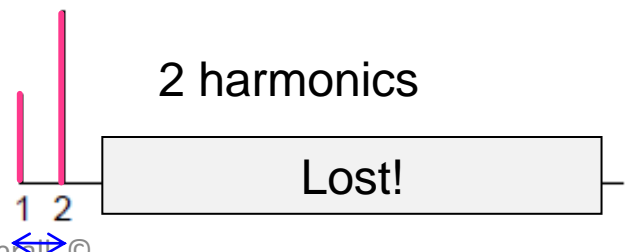
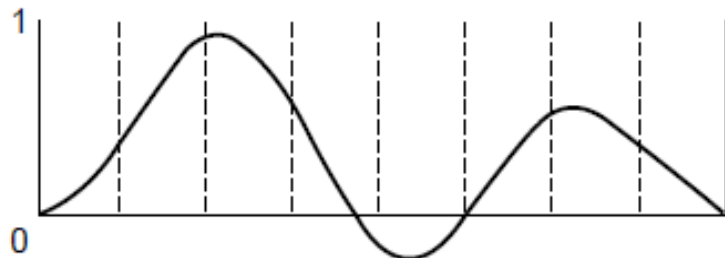
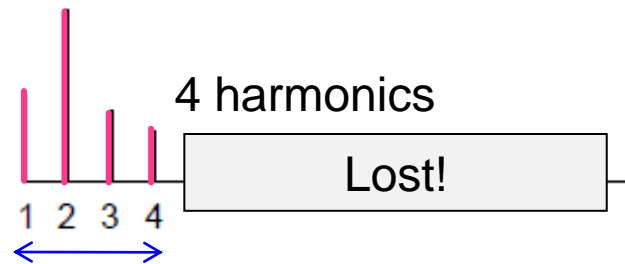
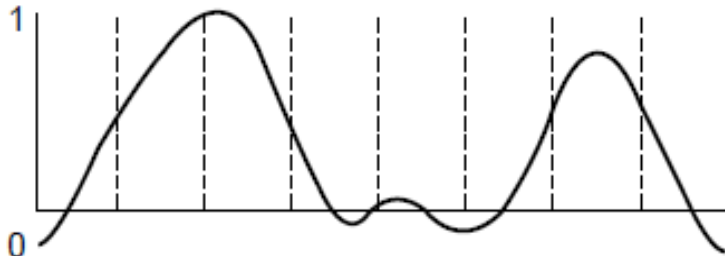
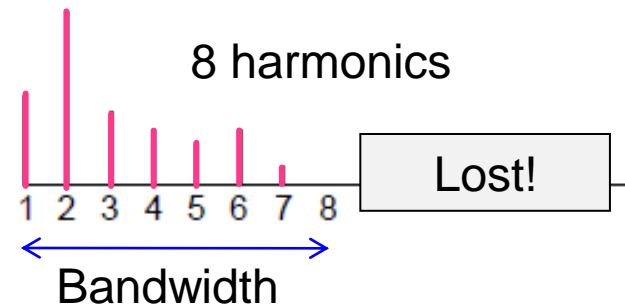
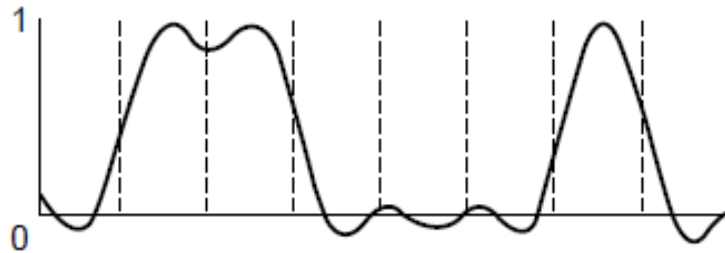

Bandwidth-Limited Signals (3)

Bps	T (msec)	First harmonic (Hz)	# Harmonics sent
300	26.67	37.5	80
600	13.33	75	40
1200	6.67	150	20
2400	3.33	300	10
4800	1.67	600	5
9600	0.83	1200	2
19200	0.42	2400	1
38400	0.21	4800	0

Guided Transmission (Wires & Fiber)

Media have different properties, hence performance

- Reality check
 - Storage media »
- Wires:
 - Twisted pairs »
 - Coaxial cable »
 - Power lines »
- Fiber cables »

Reality Check: Storage media

Send data on tape / disk / DVD for a high bandwidth link

- Mail one box with 1000 800GB tapes (6400 Tbit)
- Takes one day to send (86,400 secs)
- Data rate is 70 Gbps.

Data rate is faster than long-distance networks!

But, the message delay is very poor.

Twisted Pair



(a)



(b)

(a) Category 3 UTP.

(b) Category 5 UTP.

Twisted Pairs

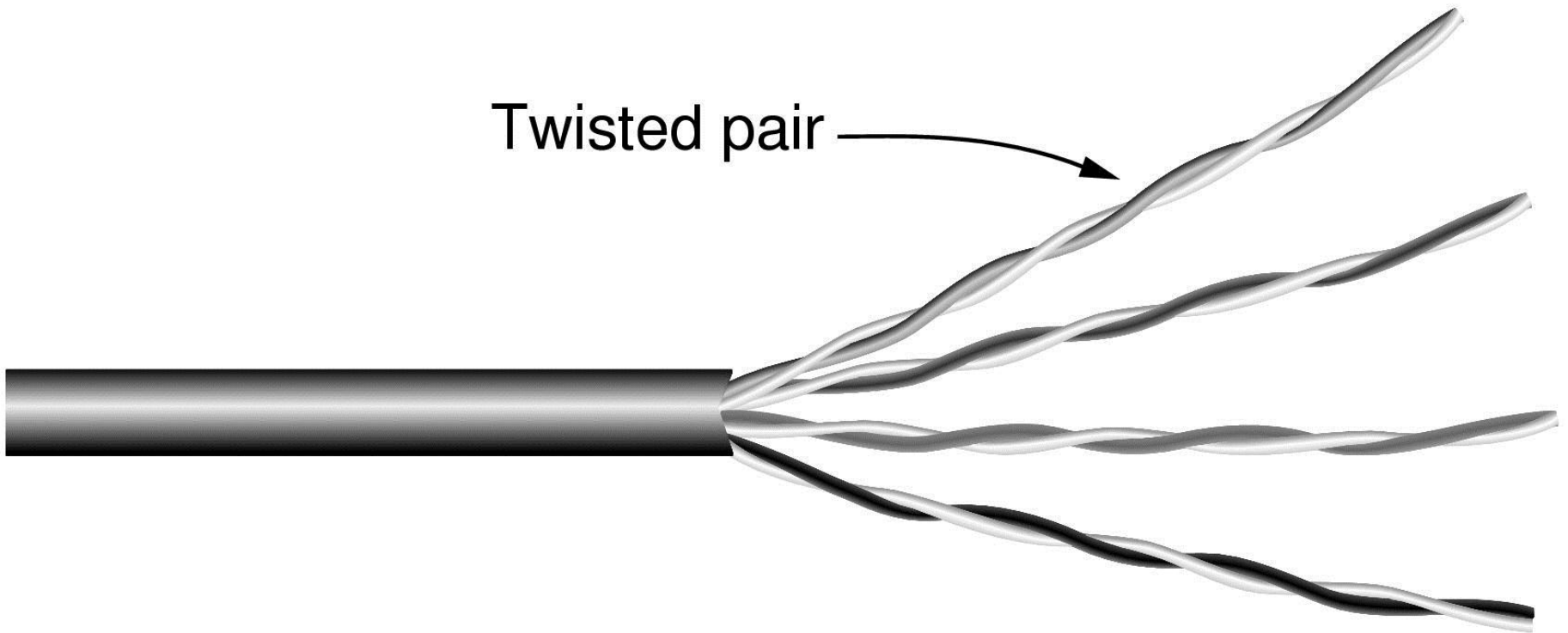

Twisted pair

Category 5 UTP cable with four twisted pairs

Link Terminology

Full-duplex link

- Used for transmission in both directions at once
- e.g., use different twisted pairs for each direction

Half-duplex link

- Both directions, but not at the same time
- e.g., senders take turns on a wireless channel

Simplex link

- Only one fixed direction at all times; not common

Coaxial Cable

A coaxial cable.

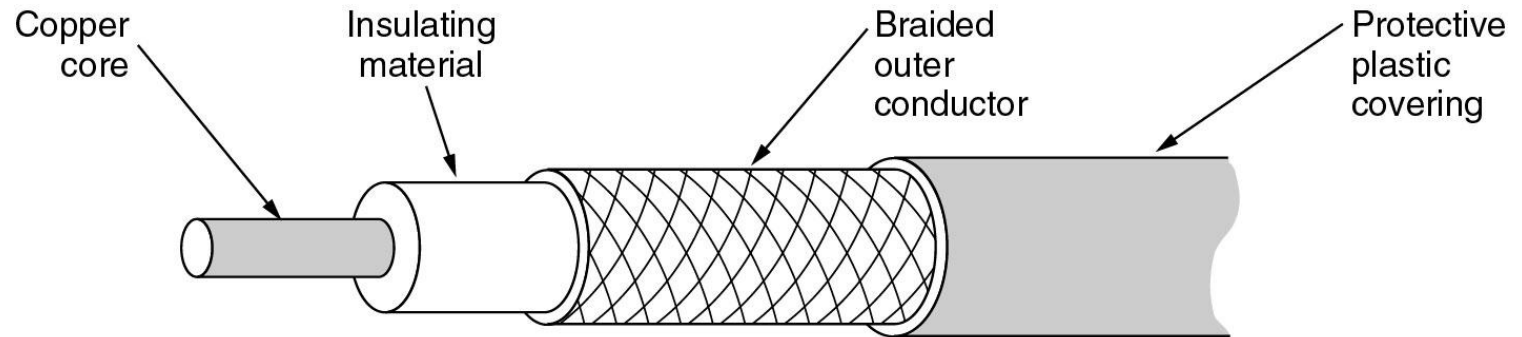

Power Lines

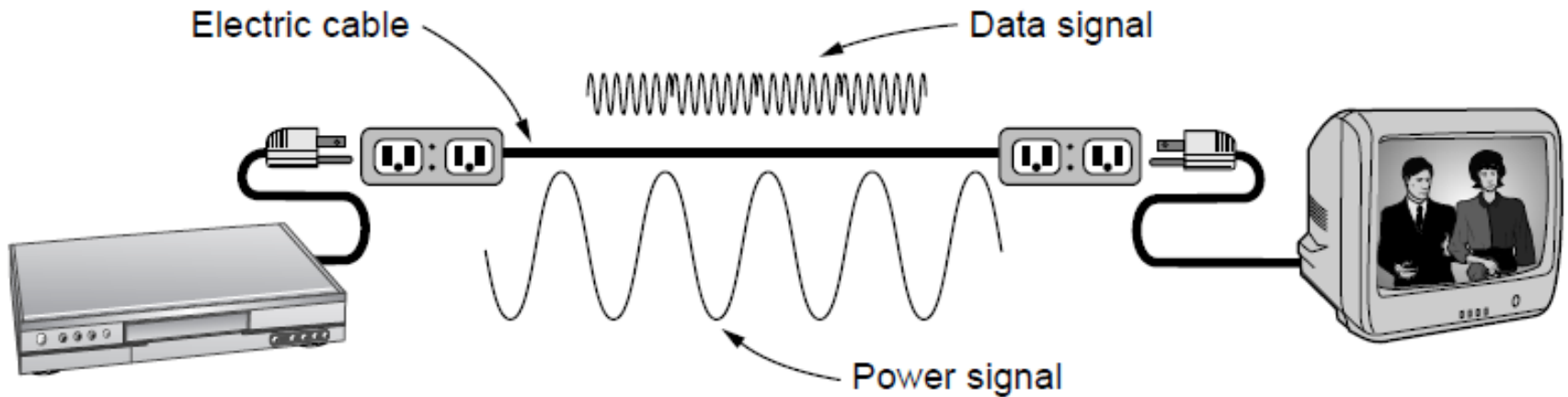

A network that uses household electrical wiring.

Fiber Optics (1)

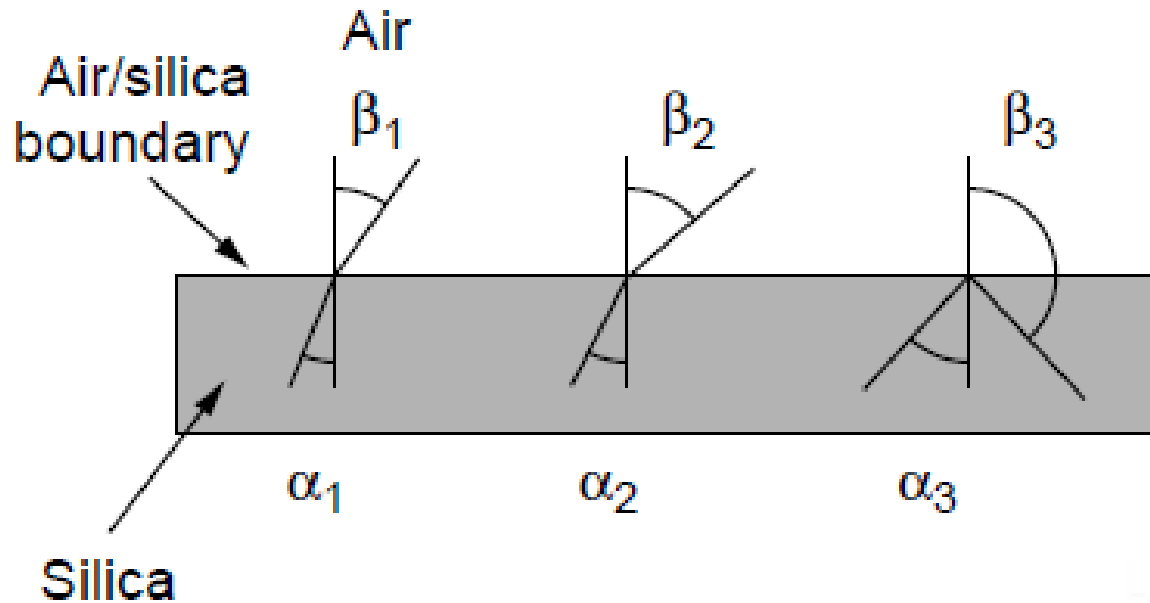

Three examples of a light ray from inside a silica fiber impinging on the air/silica boundary at different angles.

Fiber Cables (1)

Common for high rates and long distances

- Long distance ISP links, Fiber-to-the-Home
- Light carried in very long, thin strand of glass

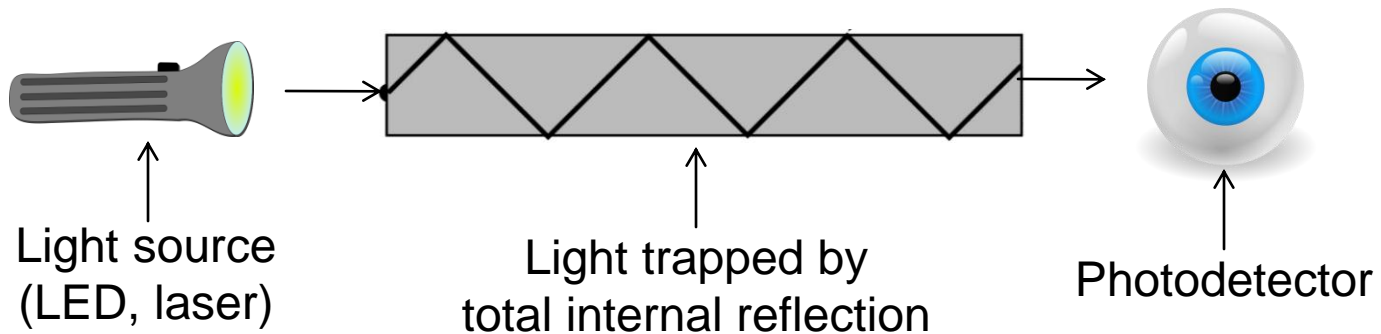

Fiber Cables (2)

Fiber has enormous bandwidth (THz) and tiny signal loss – hence high rates over long distances

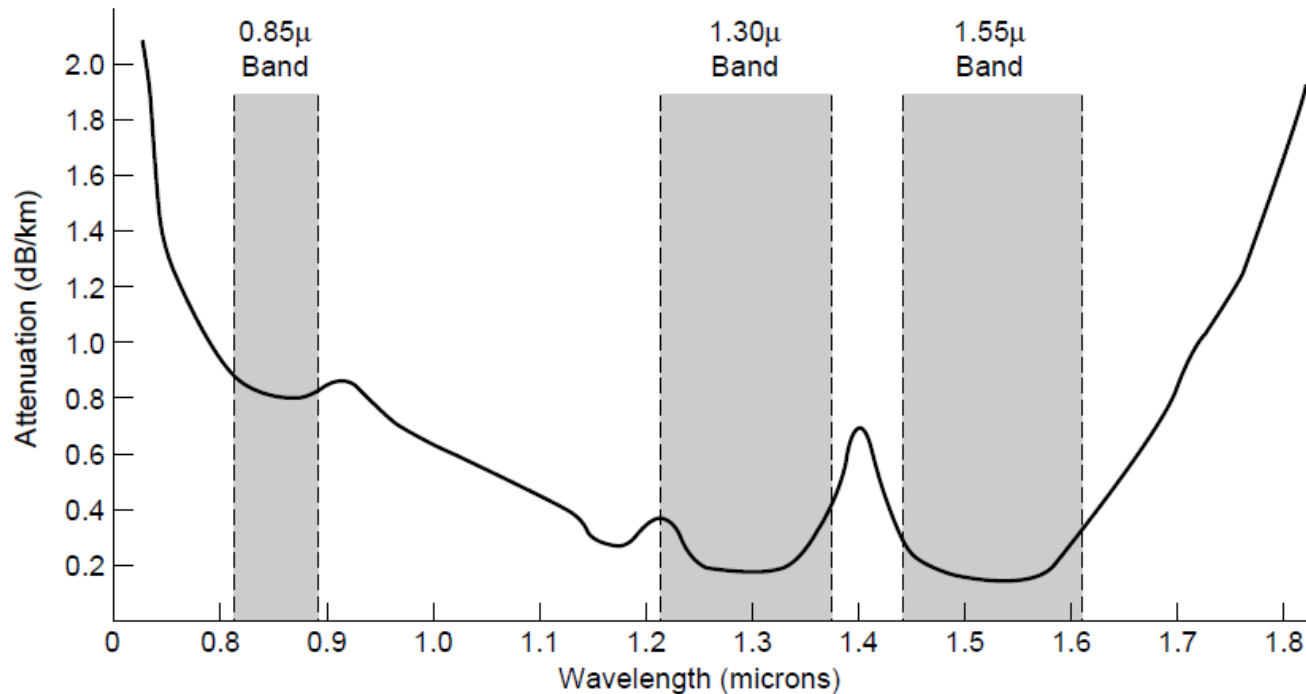

Fiber Cables (3)

Single-mode

- Core so narrow (10um) light can't even bounce around
- Used with lasers for long distances, e.g., 100km

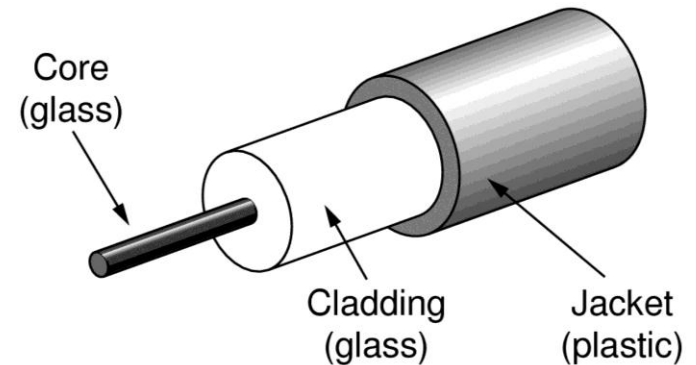

Multi-mode

- Other main type of fiber
- Light can bounce (50um core)
- Used with LEDs for cheaper, shorter distance links

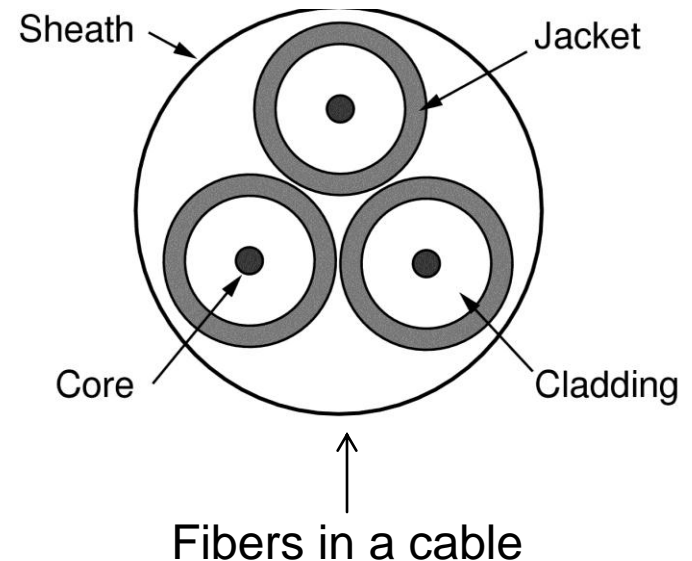

Fiber Cables (4)

Comparison of the properties of wires and fiber:

Property	Wires	Fiber
Distance	Short (100s of m)	Long (tens of km)
Bandwidth	Moderate	Very High
Cost	Inexpensive	Less cheap
Convenience	Easy to use	Less easy
Security	Easy to tap	Hard to tap

Fiber Optic Networks

A fiber optic ring with active repeaters.

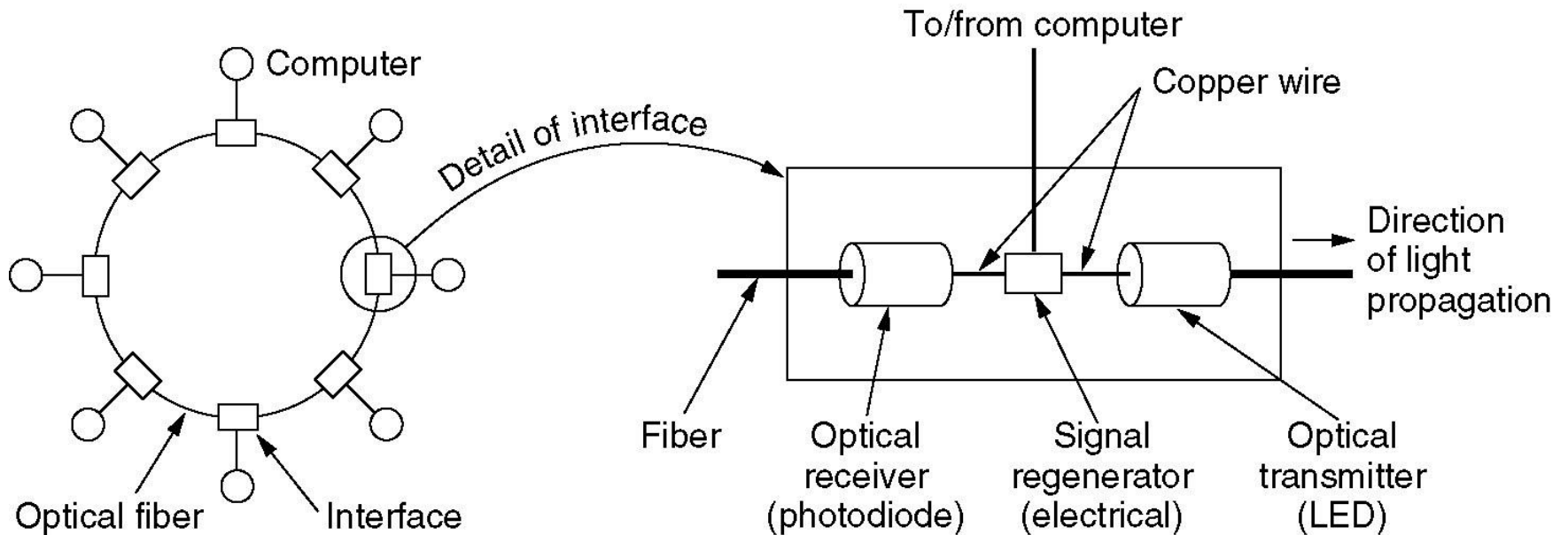

Fiber Optic Networks (2)

A passive star connection in a fiber optics network.

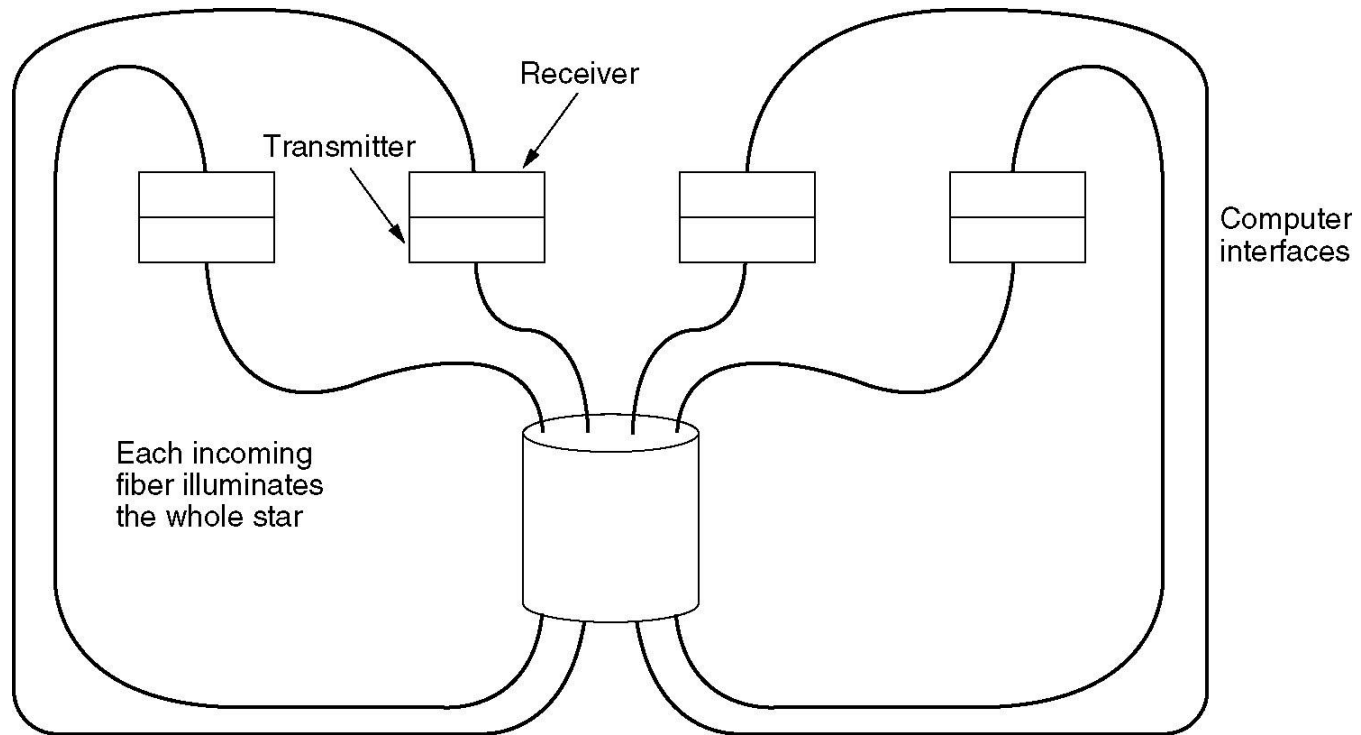

Wireless Transmission

- Electromagnetic Spectrum »
- Radio Transmission »
- Microwave Transmission »
- Light Transmission »
- Wireless vs. Wires/Fiber »

Electromagnetic Spectrum (1)

Different bands have different uses:

- Radio: wide-area broadcast; Infrared/Light: line-of-sight
- Microwave: LANs and 3G/4G; ← Networking focus

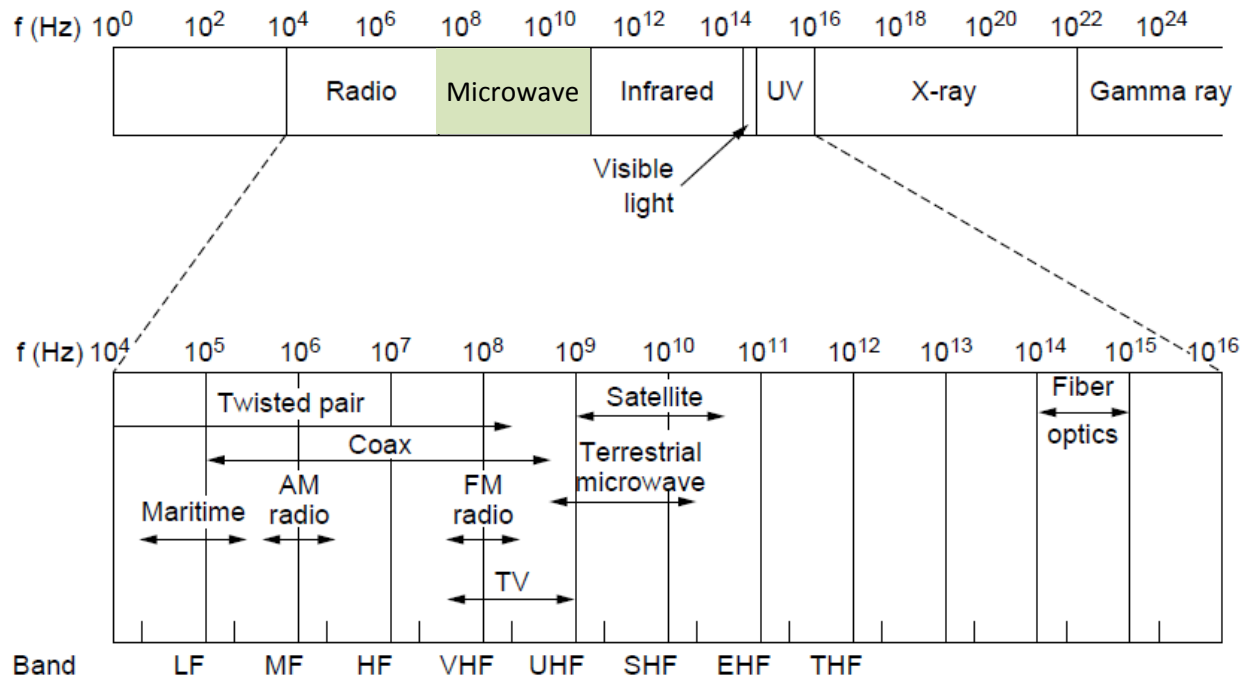

Electromagnetic Spectrum (3)

Fortunately, there are also unlicensed (“ISM”) bands:

- Free for use at low power; devices manage interference
- Widely used for networking; WiFi, Bluetooth, Zigbee, etc.

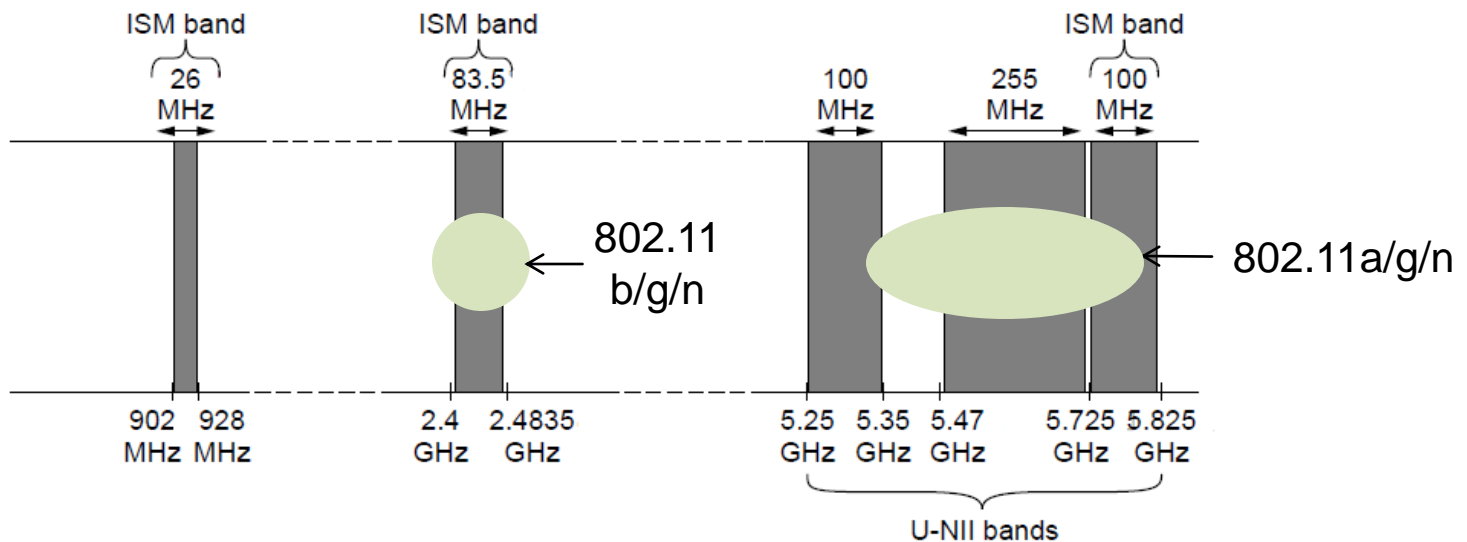

The Electromagnetic Spectrum (2)

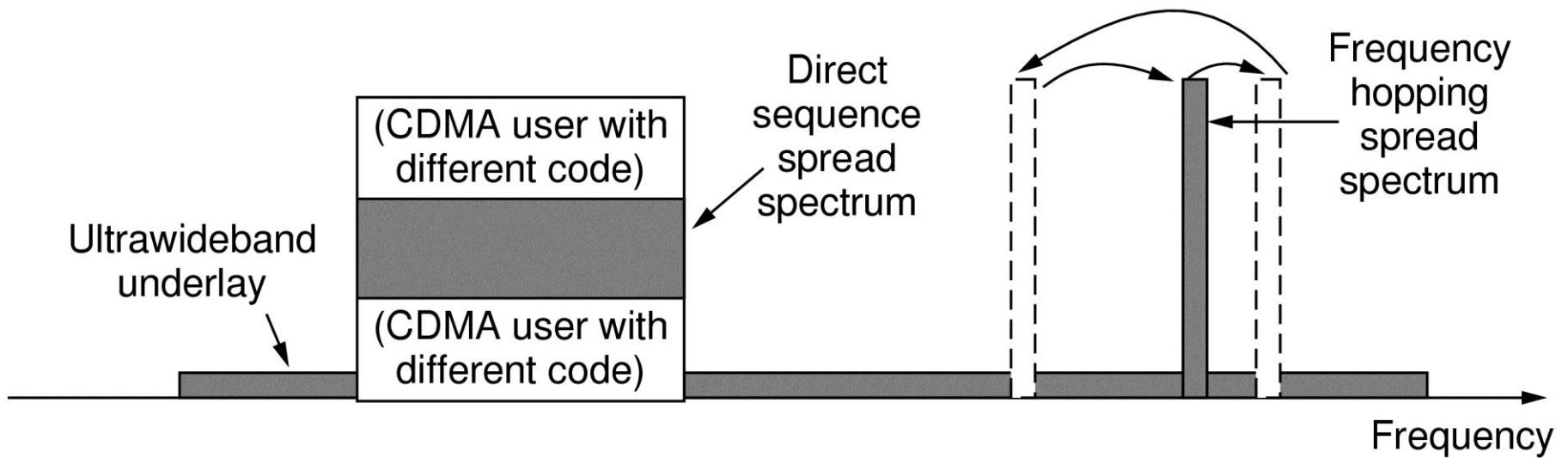

Spread spectrum and ultra-wideband (UWB) communication

Radio Transmission

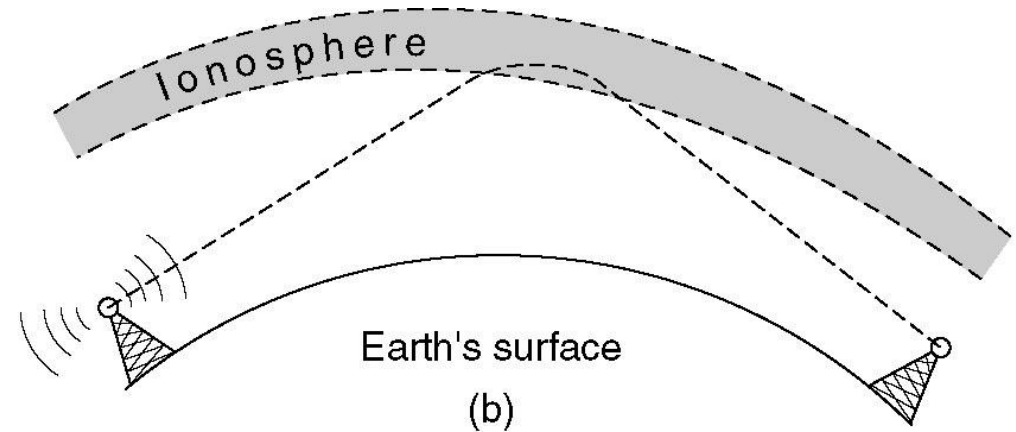
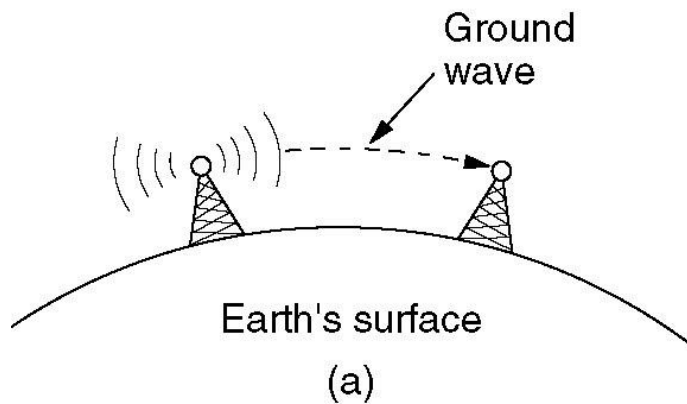

(a) In the VLF, LF, and MF bands, radio waves follow the curvature of the earth.

(b) In the HF band, they bounce off the ionosphere.

Microwave Transmission

- Microwaves have much bandwidth and are widely used indoors (WiFi) and outdoors (3G, satellites)
 - Signal is attenuated/reflected by everyday objects
 - Strength varies with mobility due multipath fading, etc.

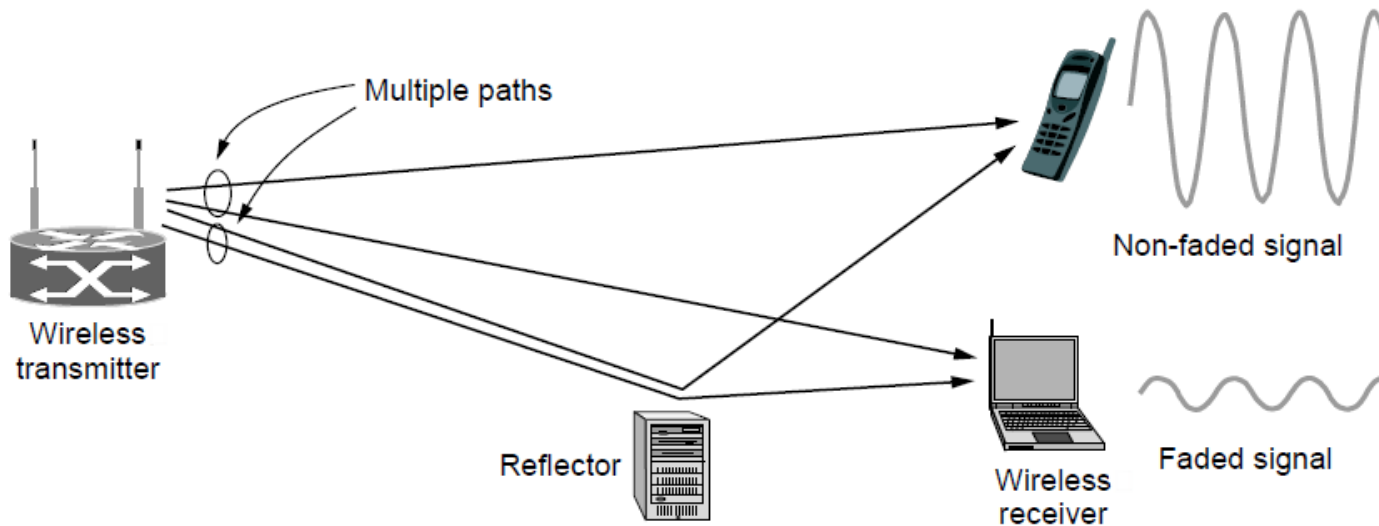

Light Transmission

Line-of-sight light (no fiber) can be used for links

- Light is highly directional, has much bandwidth
- Use of LEDs/cameras and lasers/photodetectors

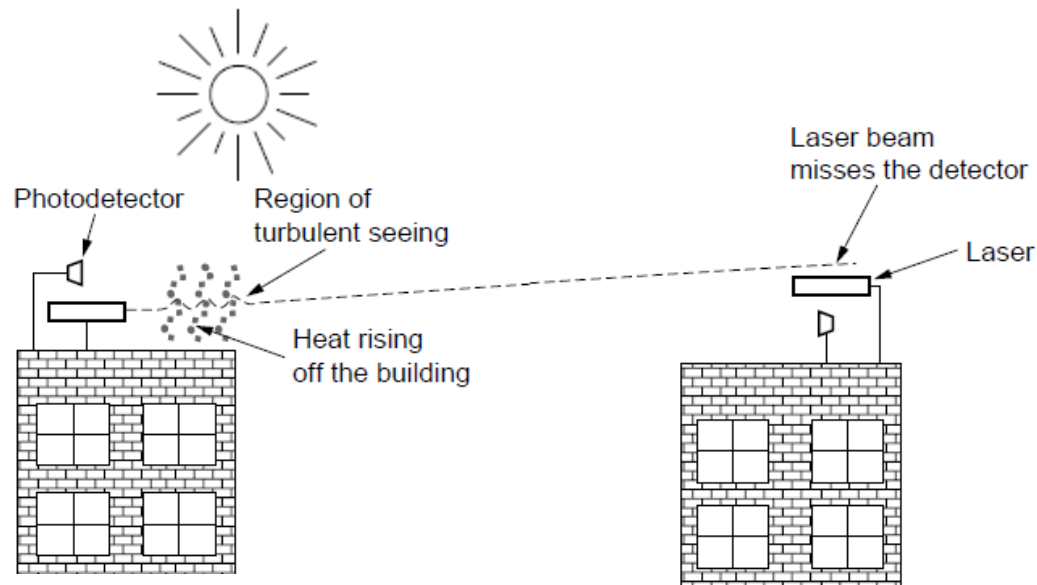

Wireless vs. Wires/Fiber

Wireless:

- + Easy and inexpensive to deploy
- + Naturally supports mobility
- + Naturally supports broadcast
- Transmissions interfere and must be managed
- Signal strengths hence data rates vary greatly

Wires/Fiber:

- + Easy to engineer a fixed data rate over point-to-point links
- Can be expensive to deploy, esp. over distances
- Doesn't readily support mobility or broadcast

Communication Satellites

Satellites are effective for broadcast distribution and anywhere/anytime communications

- Kinds of Satellites »
- Geostationary (GEO) Satellites »
- Low-Earth Orbit (LEO) Satellites »
- Satellites vs. Fiber »

Kinds of Satellites

Satellites and their properties vary by altitude:

— Geostationary (GEO). Medium-Earth Orbit

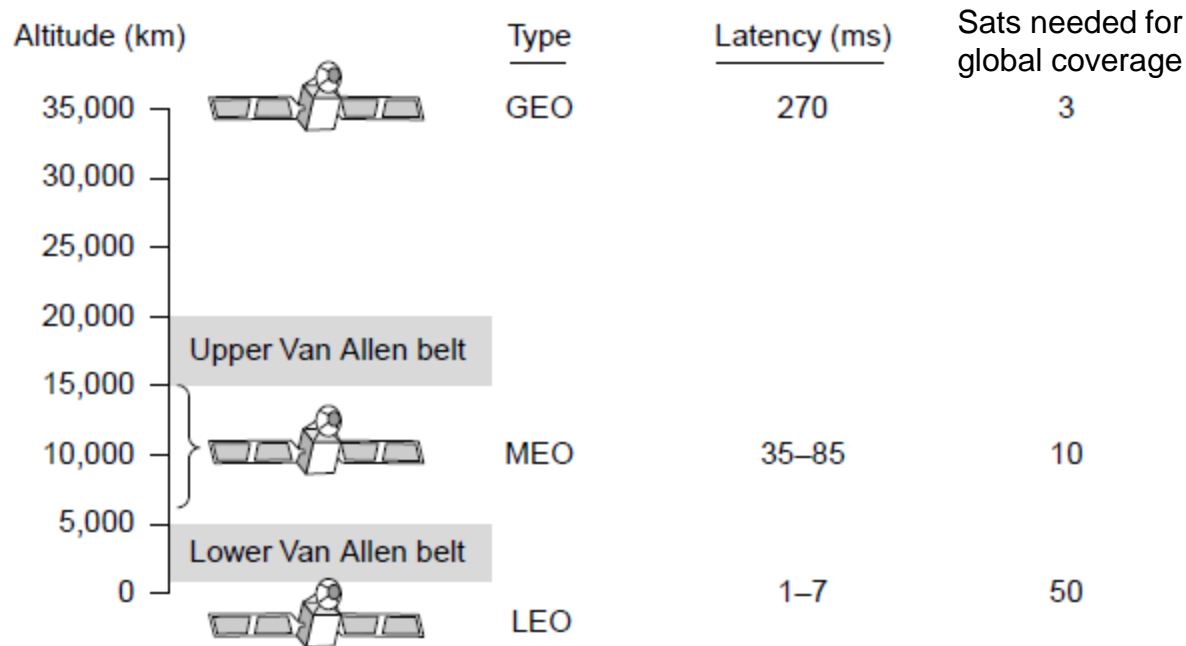

Communication Satellites (2)

The principal satellite bands.

Band	Downlink	Uplink	Bandwidth	Problems
L	1.5 GHz	1.6 GHz	15 MHz	Low bandwidth; crowded
S	1.9 GHz	2.2 GHz	70 MHz	Low bandwidth; crowded
C	4.0 GHz	6.0 GHz	500 MHz	Terrestrial interference
Ku	11 GHz	14 GHz	500 MHz	Rain
Ka	20 GHz	30 GHz	3500 MHz	Rain, equipment cost

Geostationary Satellites

GEO satellites orbit 35,000 km above a fixed location

- VSAT (computers) can communicate with the help of a hub
- Different bands (L, S, C, Ku, Ka) in the GHz are in use but may be crowded or susceptible to rain.

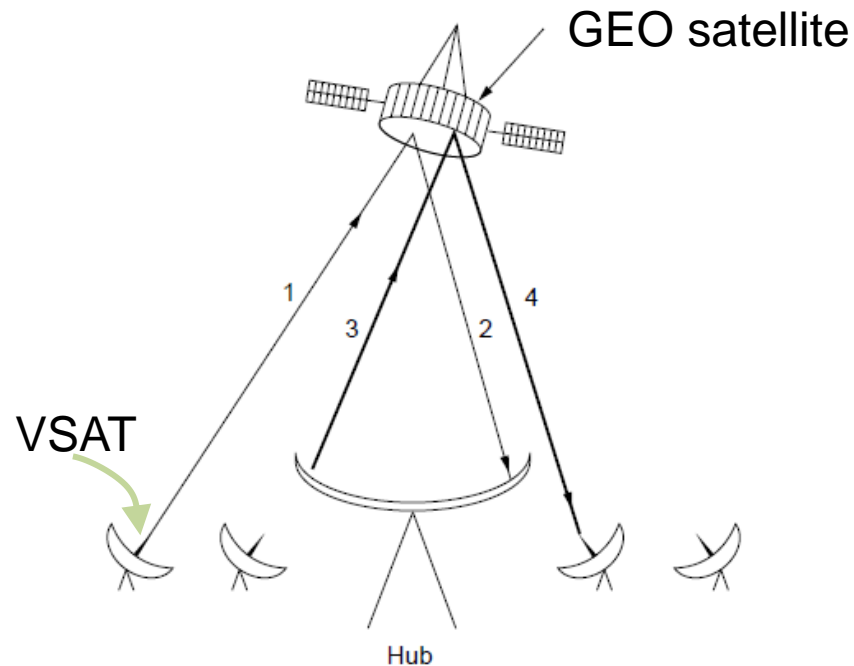

Low-Earth Orbit Satellites

Iridium

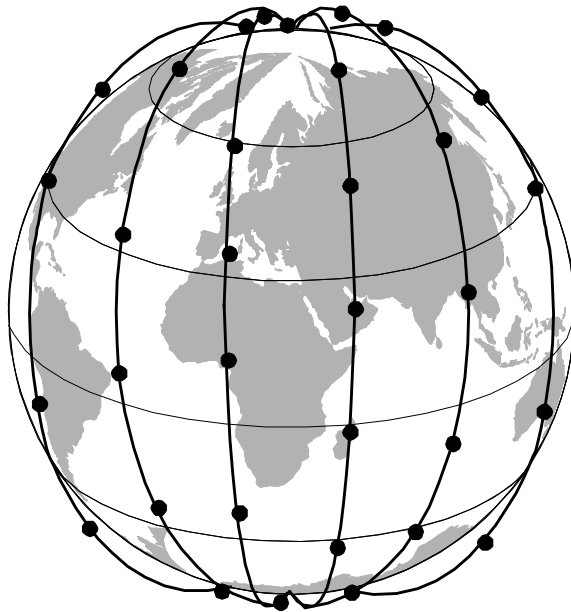

(a)

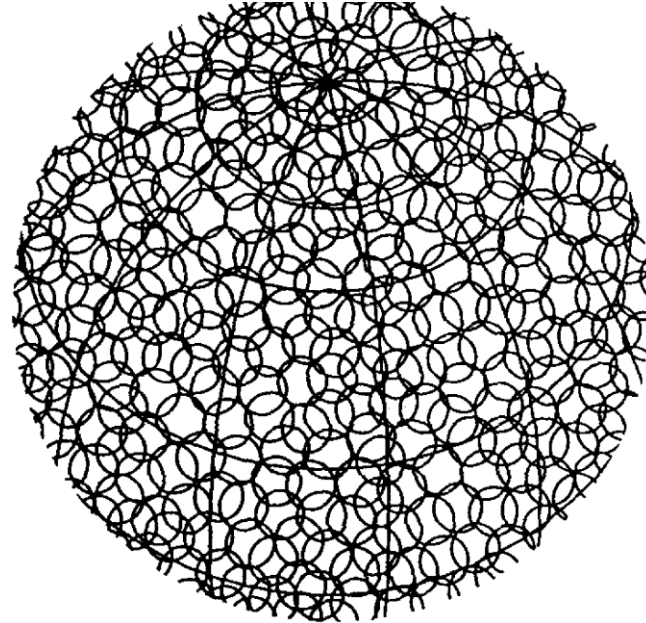

(b)

(a) The Iridium satellites from six necklaces around the earth.

(b) 1628 moving cells cover the earth.

Globalstar

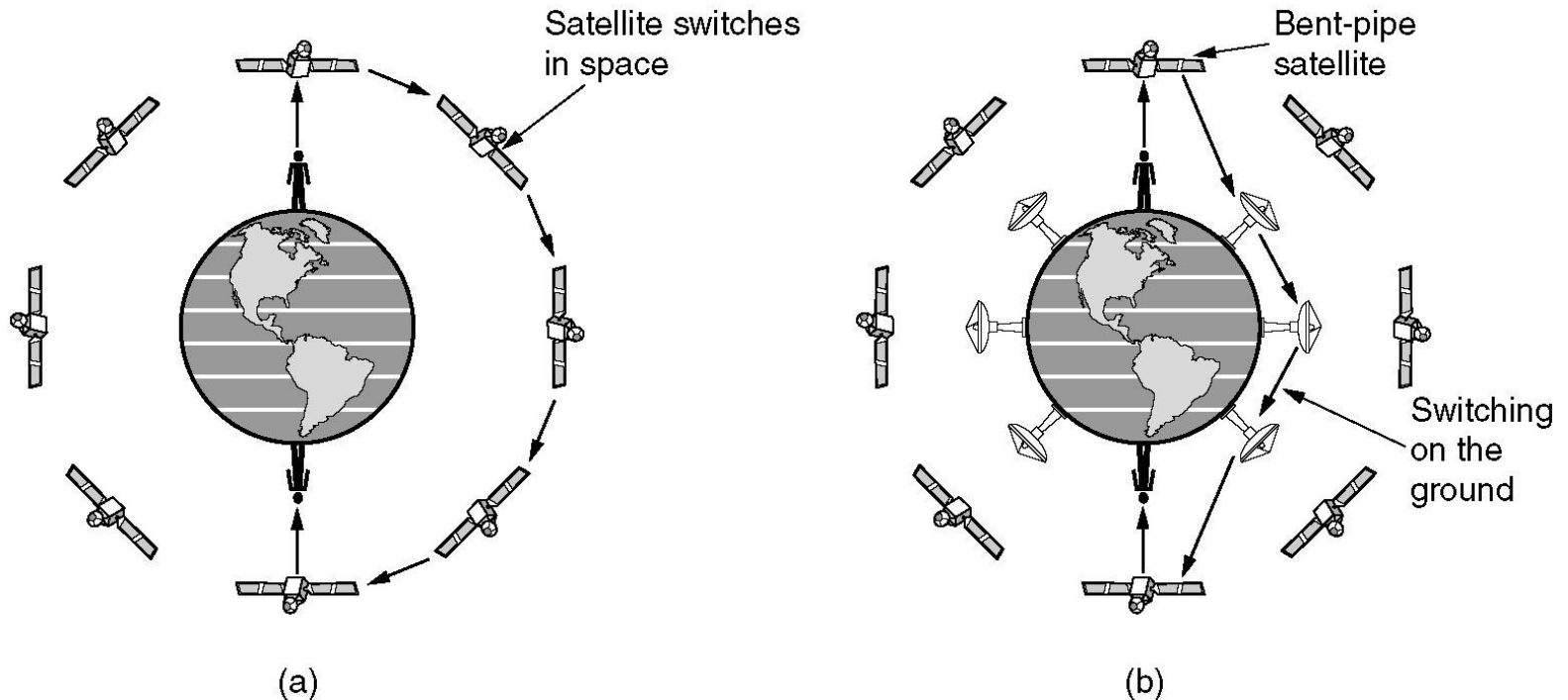

(a) Relaying in space.

(b) Relaying on the ground.

Satellite vs. Fiber

Satellite:

- + Can rapidly set up anywhere/anytime communications (after satellites have been launched)
- + Can broadcast to large regions
- Limited bandwidth and interference to manage

Fiber:

- + Enormous bandwidth over long distances
- Installation can be more expensive/difficult

Digital Modulation and Multiplexing

Modulation schemes send bits as signals;
multiplexing schemes share a channel
among users.

- Baseband Transmission »
- Passband Transmission »
- Frequency Division Multiplexing »
- Time Division Multiplexing »
- Code Division Multiple Access »

Baseband Transmission

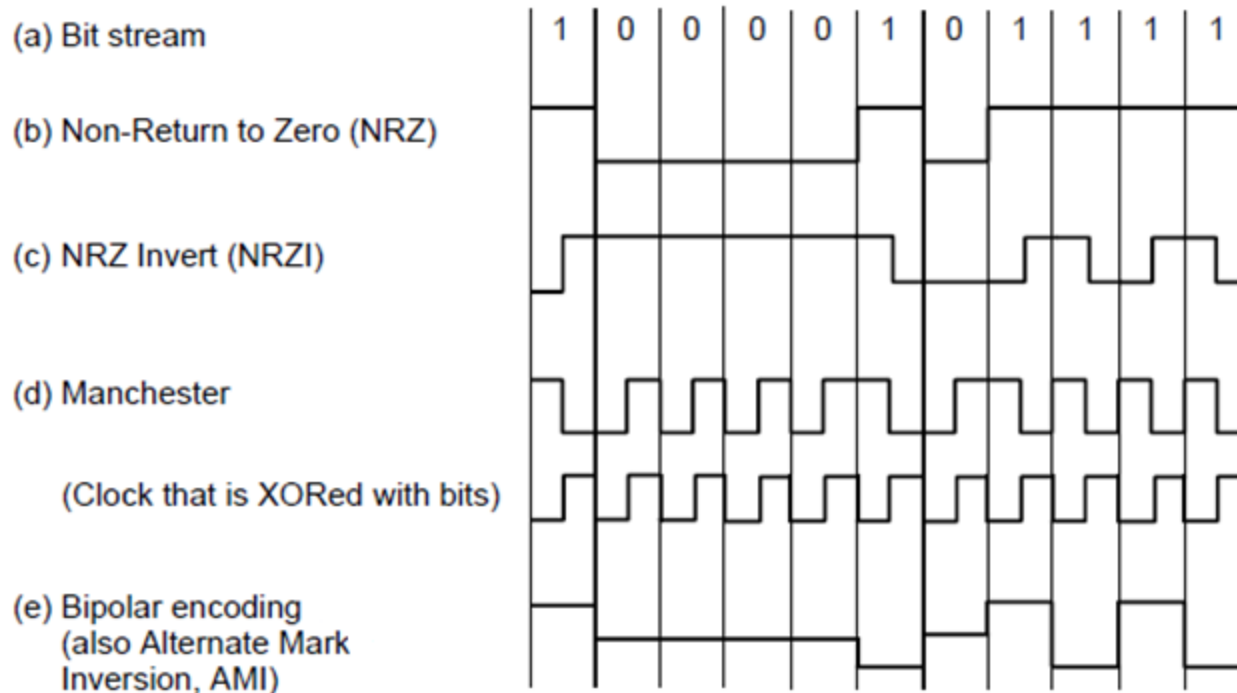

Line codes: (a) Bits, (b) NRZ, (c) NRZI,
(d) Manchester, (e) Bipolar or AMI.

Baseband Transmission

- Line codes send symbols that represent one or more bits
 - NRZ is the simplest, literal line code (+1V="1", -1V="0")
 - Other codes tradeoff bandwidth and signal transitions

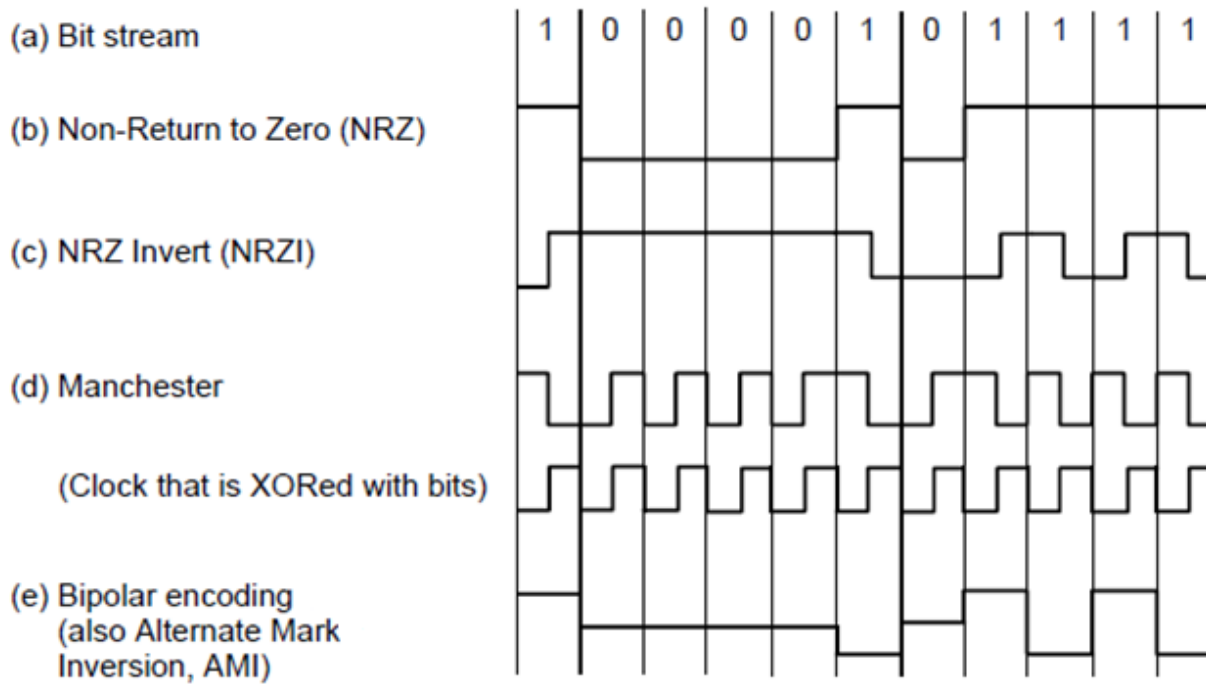

Four different line codes

CN5E by Tanenbaum & Wetherall, ©
Pearson Education-Prentice Hall and D.
Wetherall, 2011

Clock Recovery

- To decode the symbols, signals need sufficient transitions
 - Otherwise long runs of 0s (or 1s) are confusing, e.g.:



- Strategies:
 - Manchester coding, mixes clock signal in every symbol
 - 4B/5B maps 4 data bits to 5 coded bits with 1s and 0s:

Data	Code	Data	Code	Data	Code	Data	Code
0000	11110	0100	01010	1000	10010	1100	11010
0001	01001	0101	01011	1001	10011	1101	11011
0010	10100	0110	01110	1010	10110	1110	11100
0011	10101	0111	01111	1011	10111	1111	11101

- Scrambler XORs tx/rx data with pseudorandom bits

Clock Recovery

Data (4B)	Codeword (5B)	Data (4B)	Codeword (5B)
0000	11110	1000	10010
0001	01001	1001	10011
0010	10100	1010	10110
0011	10101	1011	10111
0100	01010	1100	11010
0101	01011	1101	11011
0110	01110	1110	11100
0111	01111	1111	11101

4B/5B mapping.

Passband Transmission (1)

Modulating the amplitude, frequency/phase of a carrier signal sends bits in a (non-zero) frequency range

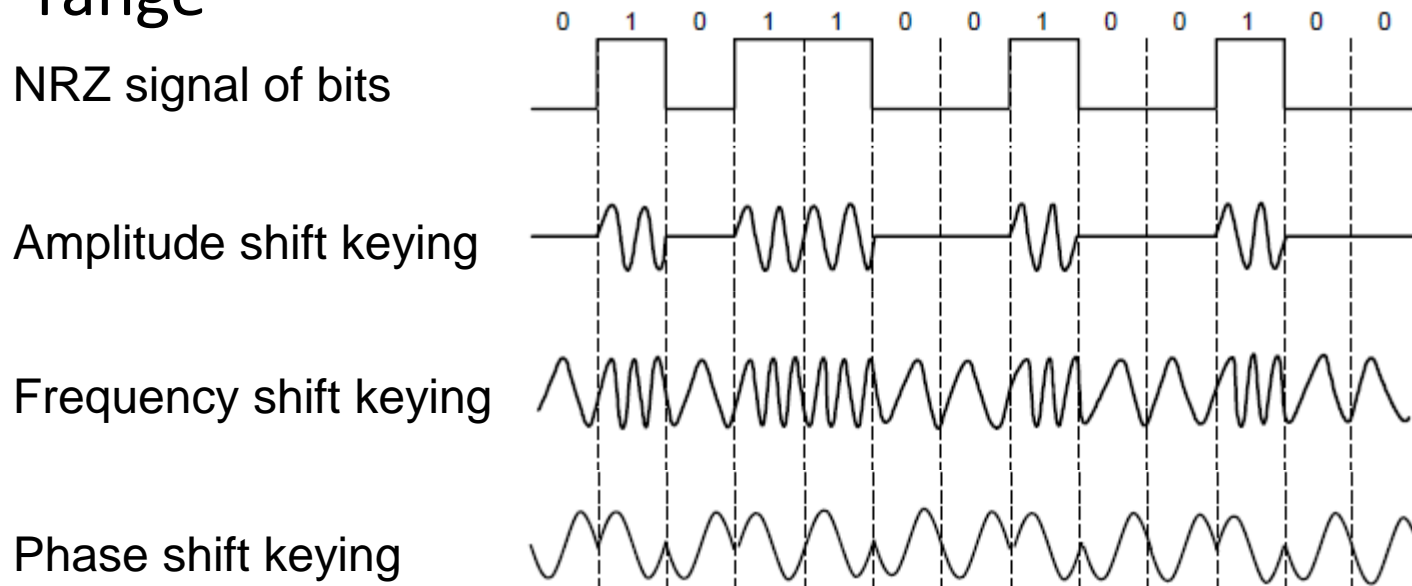

Passband Transmission (2)

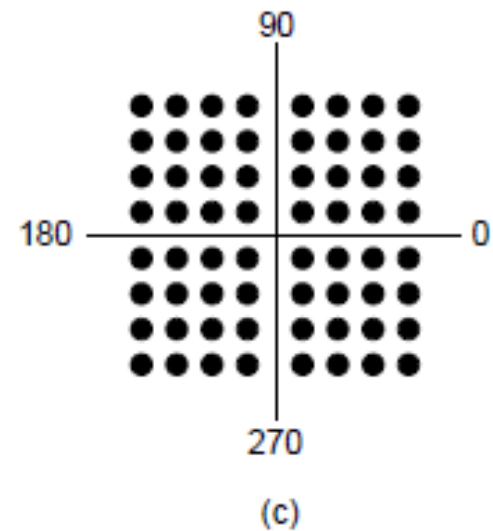
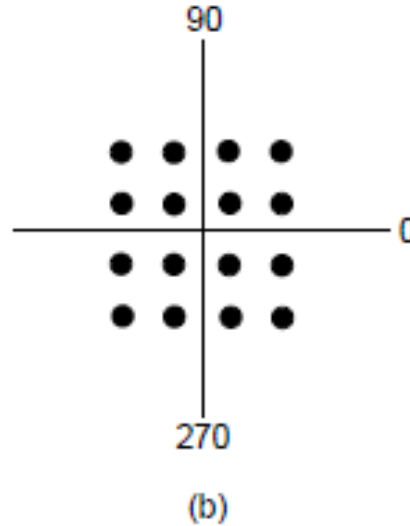
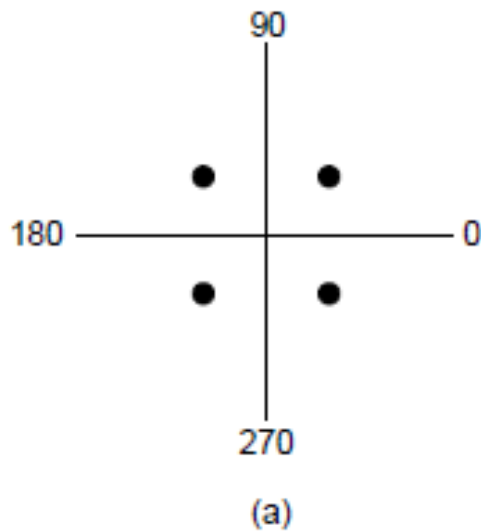

(a) QPSK. (b) QAM-16. (c) QAM-64.

Passband Transmission (3)

Gray-coding assigns bits to symbols so that small symbol errors cause few bit errors:



When 1101 is sent:

Point	Decodes as	Bit errors
A	1101	0
B	110 <u>0</u>	1
C	<u>1</u> 001	1
D	11 <u>1</u> 1	1
E	<u>0</u> 101	1

Modems (3)

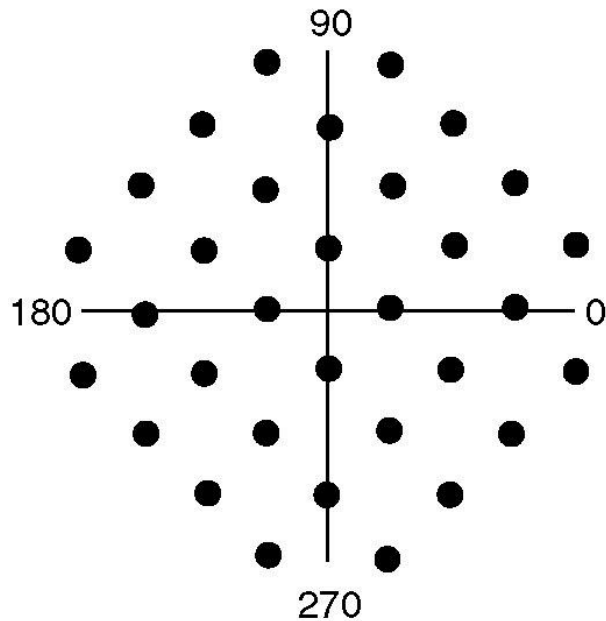

(a)

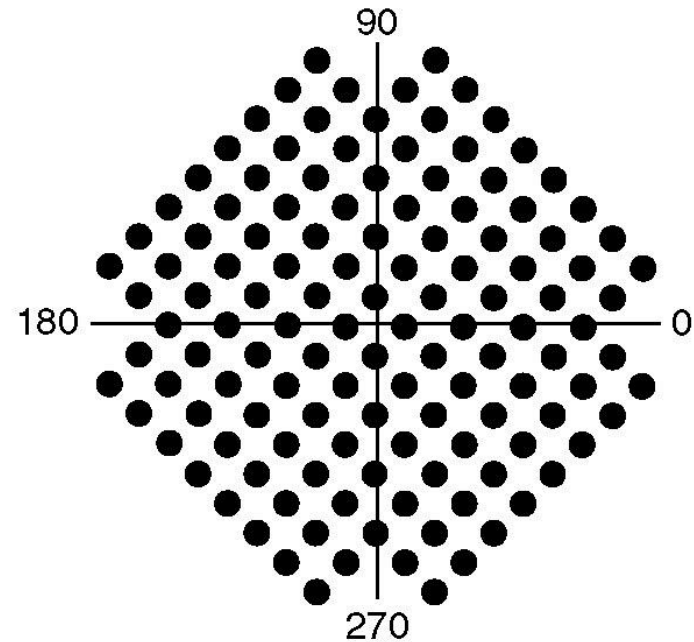

(b)

(a) V.32 for 9600 bps.

(b) V.32 bis for 14,400 bps.

Frequency Division Multiplexing (1)

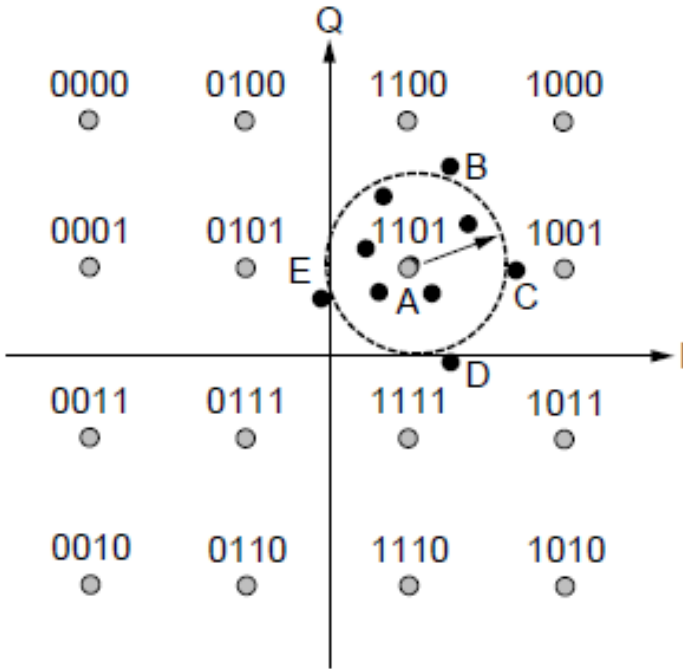

When 1101 is sent:

Point	Decodes as	Bit errors
A	1101	0
B	110 <u>0</u>	1
C	<u>1</u> 001	1
D	11 <u>1</u> 1	1
E	<u>0</u> 101	1

Gray-coded QAM-16.

Frequency Division Multiplexing (2)

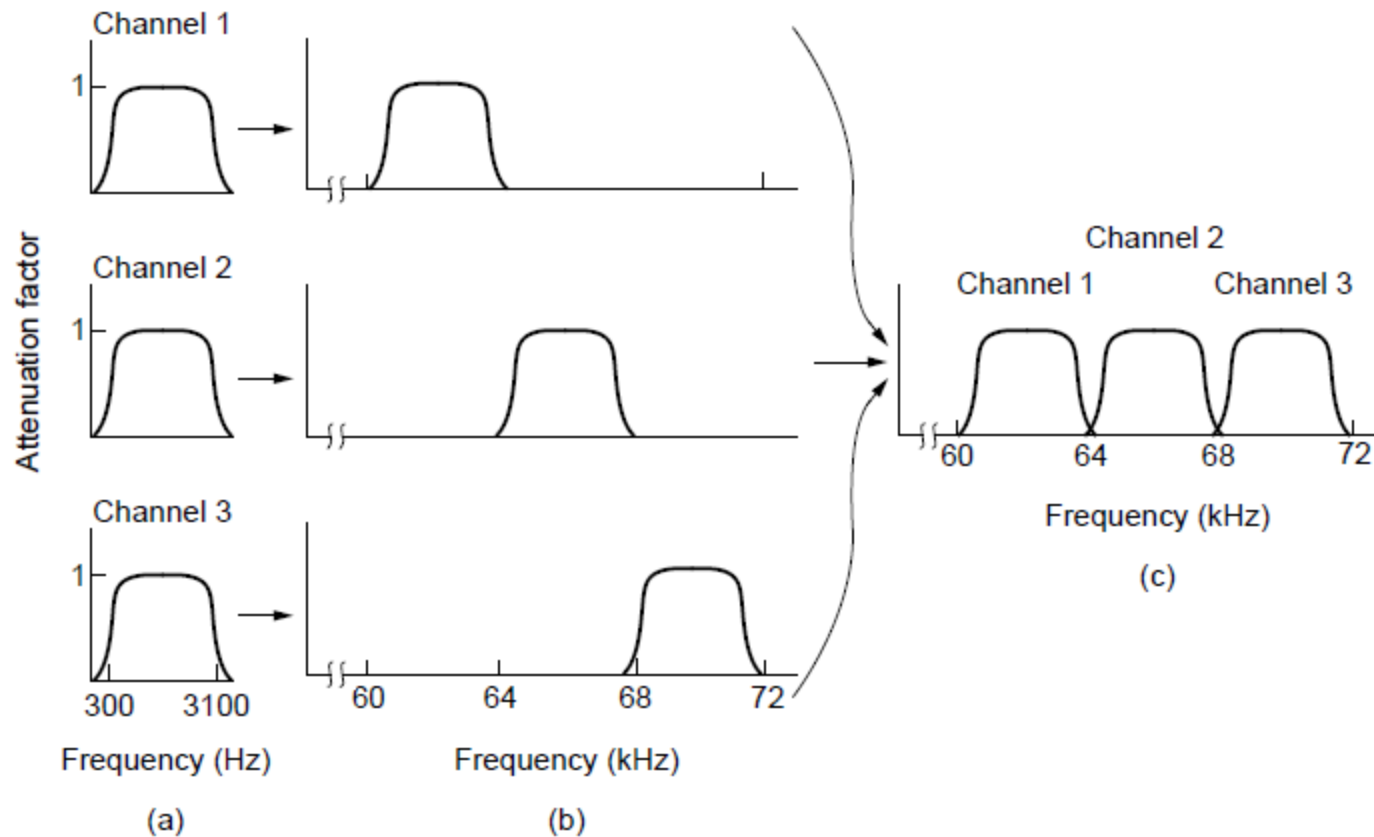

Frequency division multiplexing. (a) The original bandwidths.
(b) The bandwidths raised in frequency.
(c) The multiplexed channel.

Frequency Division Multiplexing (3)

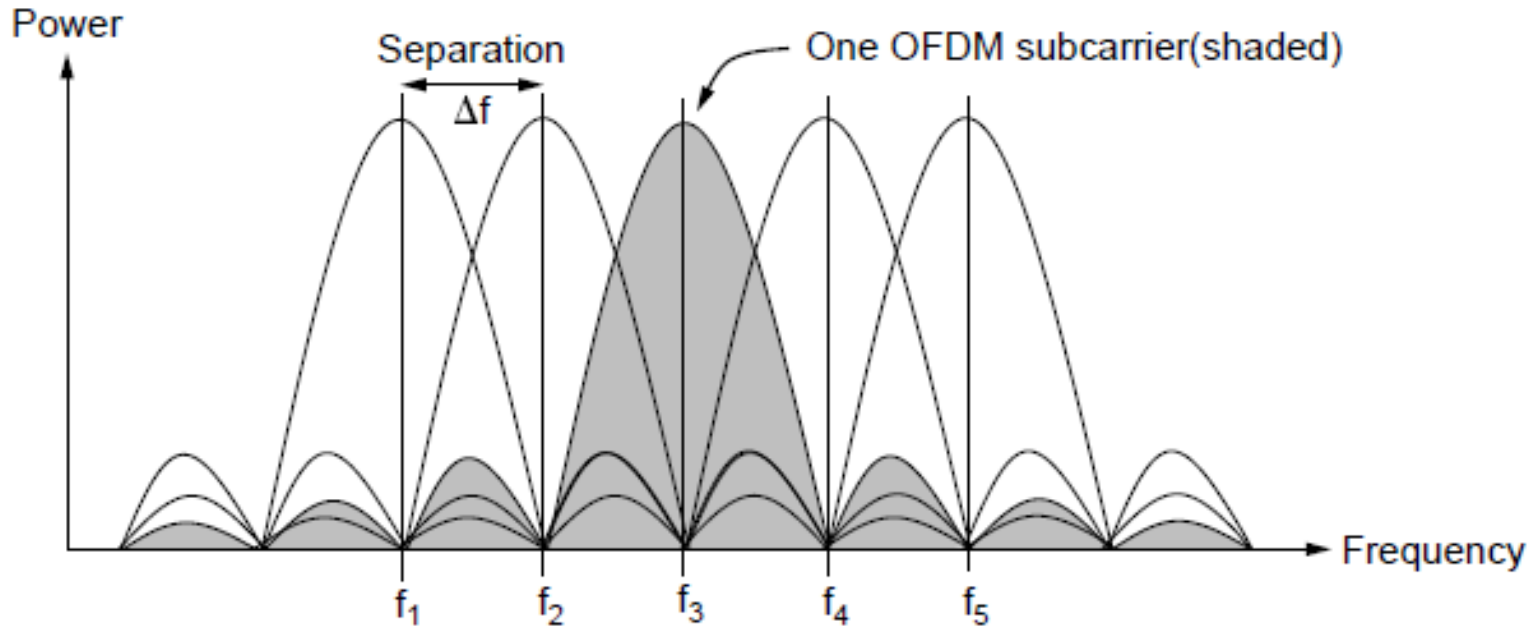

Orthogonal frequency division
multiplexing (OFDM).

Time Division Multiplexing (TDM)

Time division multiplexing shares a channel over time:

- Users take turns on a fixed schedule; this is not packet switching or STDM (Statistical TDM)
- Widely used in telephone / cellular systems

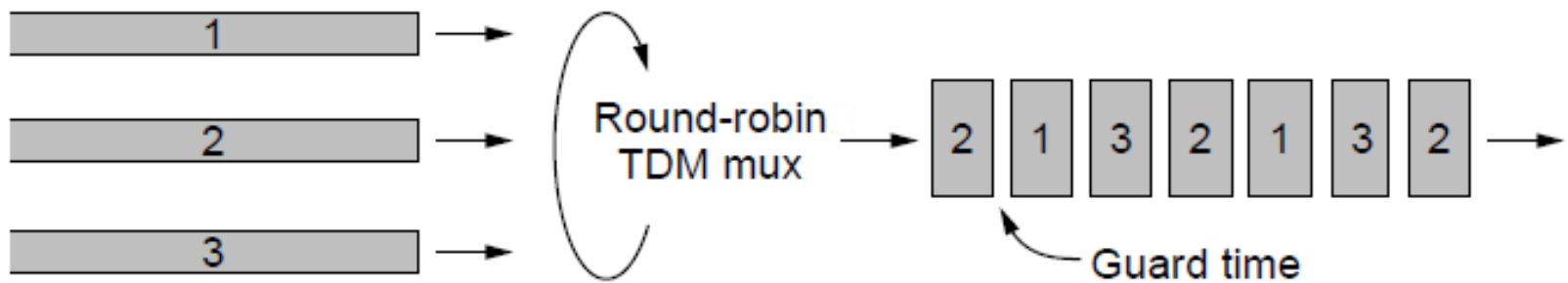

Code Division Multiple Access (CDMA)

CDMA shares the channel by giving users a code

- Codes are orthogonal; can be sent at the same time
- Widely used as part of 3G networks

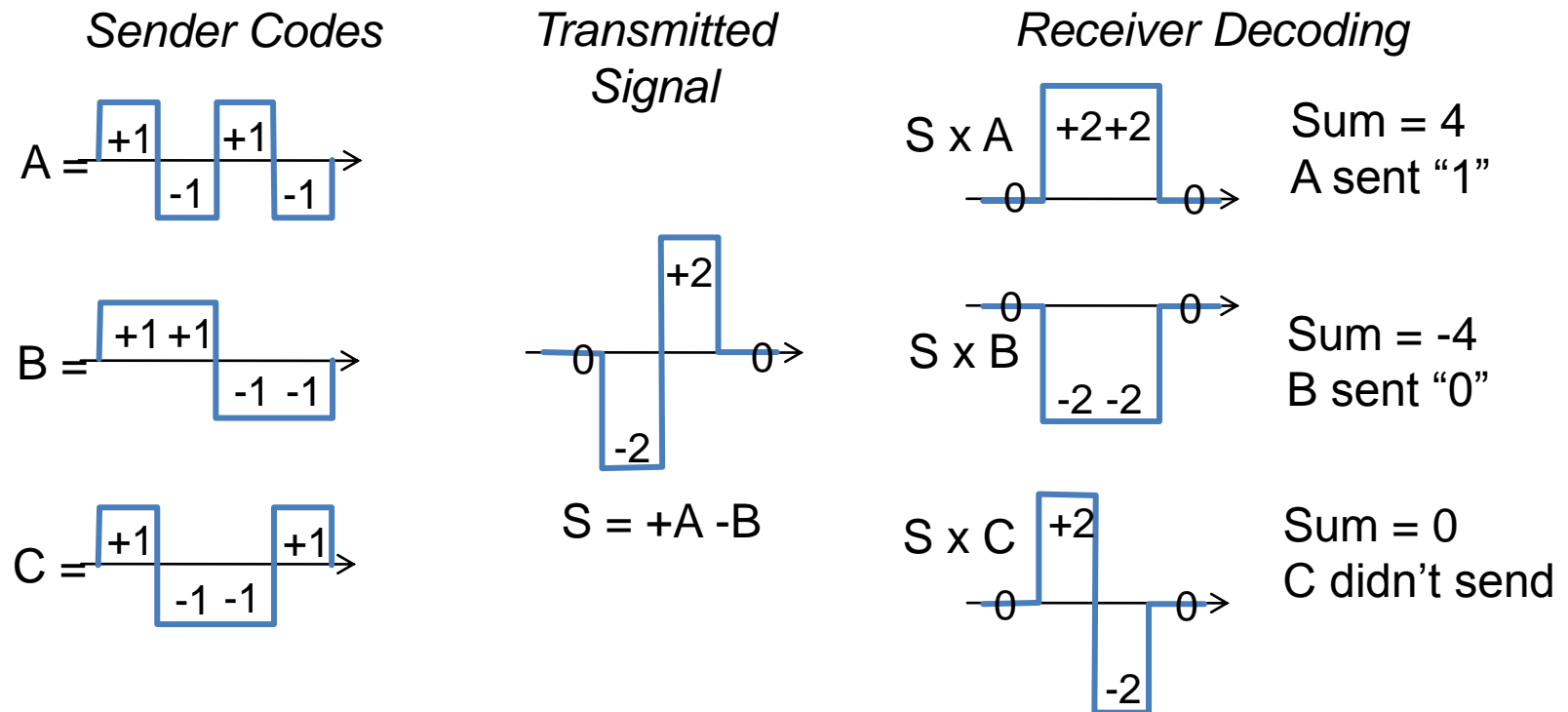

Code Division Multiplexing (1)

$$A = (-1 \ -1 \ -1 \ +1 \ +1 \ -1 \ +1 \ +1)$$

$$B = (-1 \ -1 \ +1 \ -1 \ +1 \ +1 \ +1 \ -1)$$

$$C = (-1 \ +1 \ -1 \ +1 \ +1 \ +1 \ -1 \ -1)$$

$$D = (-1 \ +1 \ -1 \ -1 \ -1 \ -1 \ +1 \ -1)$$

(a)

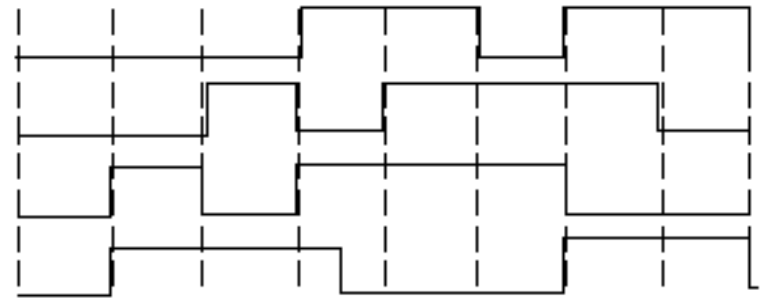

(b)

(a) Chip sequences for four stations.

(b) Signals the sequences represent

Code Division Multiplexing (2)

$S_1 = C$	$= (-1 +1 -1 +1 +1 +1 -1 -1)$	$S_1 \bullet C = [1+1-1+1+1+1-1-1]/8 = 1$
$S_2 = B+\underline{C}$	$= (-2 \ 0 \ 0 \ 0 +2 +2 \ 0 -2)$	$S_2 \bullet C = [2+0+0+0+2+2+0+2]/8 = 1$
$S_3 = A+\underline{B}$	$= (\ 0 \ 0 -2 +2 \ 0 -2 \ 0 +2)$	$S_3 \bullet C = [0+0+2+2+0-2+0-2]/8 = 0$
$S_4 = A+\underline{B}+C$	$= (-1 +1 -3 +3 +1 -1 -1 +1)$	$S_4 \bullet C = [1+1+3+3+1-1+1-1]/8 = 1$
$S_5 = A+B+\underline{C}+D$	$= (-4 \ 0 -2 \ 0 +2 \ 0 +2 -2)$	$S_5 \bullet C = [4+0+2+0+2+0-2+2]/8 = 1$
$S_6 = A+B+\underline{C}+D$	$= (-2 -2 \ 0 -2 \ 0 -2 +4 \ 0)$	$S_6 \bullet C = [2-2+0-2+0-2-4+0]/8 = -1$

(c) (d)

(a) Six examples of transmissions.

(b) Recovery of station C's

Public Switched Telephone System

- Structure of the Telephone System
- The Politics of Telephones
- The Local Loop: Modems, ADSL and Wireless
- Trunks and Multiplexing
- Switching

Structure of the Telephone System

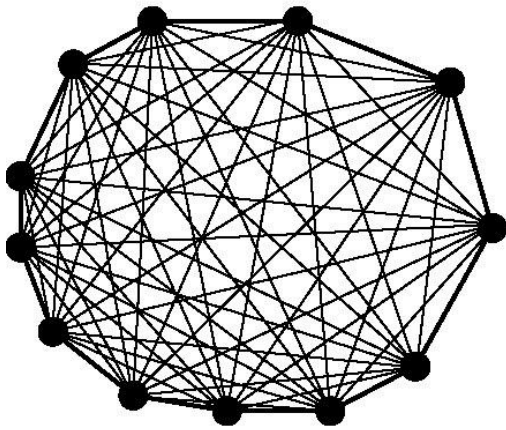

(a)

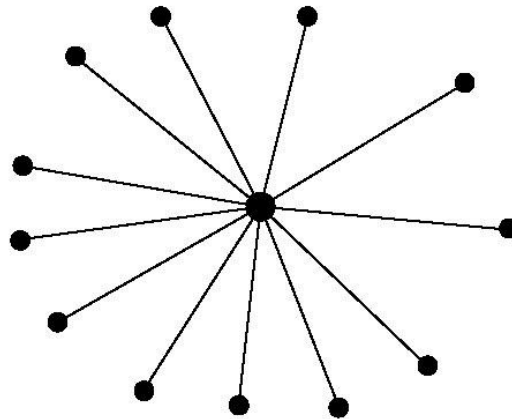

(b)

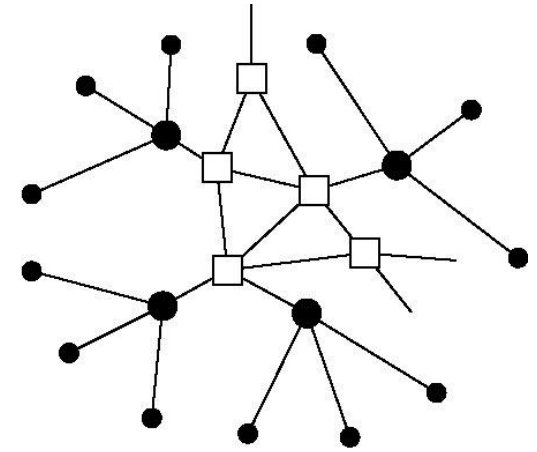

(c)

(a) Fully-interconnected network.

(b) Centralized switch.

(c) Two-level hierarchy.

Structure of the Telephone System

A hierarchical system for carrying voice calls made of:

- Local loops, mostly analog twisted pairs to houses
- Trunks, digital fiber optic links that carry calls
- Switching offices, that move calls among trunks

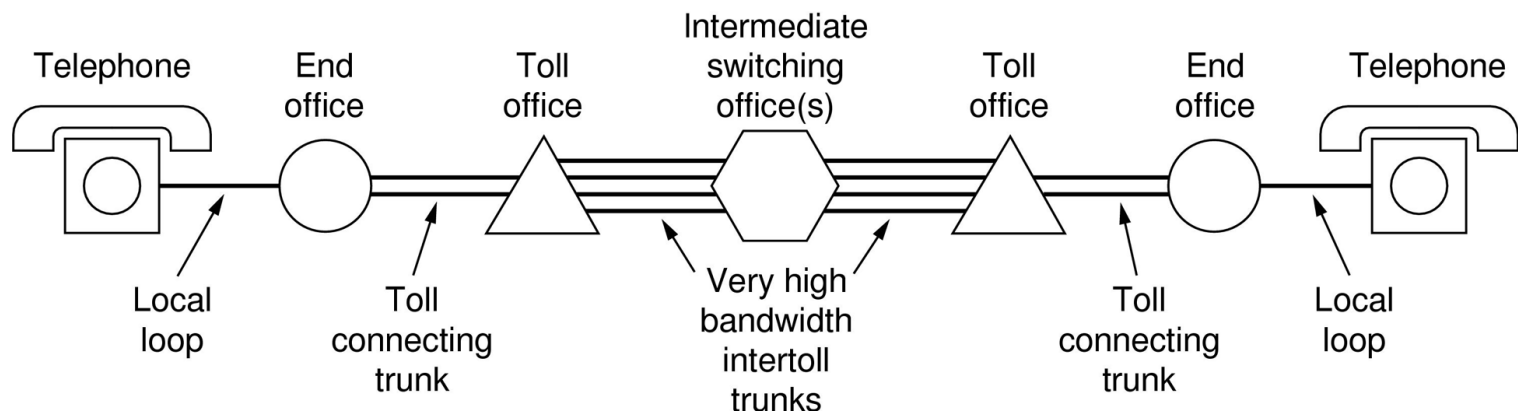

The Politics of Telephones

- In the U.S., there is a distinction for competition between serving a local area (LECs) and connecting to a local area (at a POP) to switch calls across areas (IXCs)
 - Customers of a LEC can dial via any IXC they choose

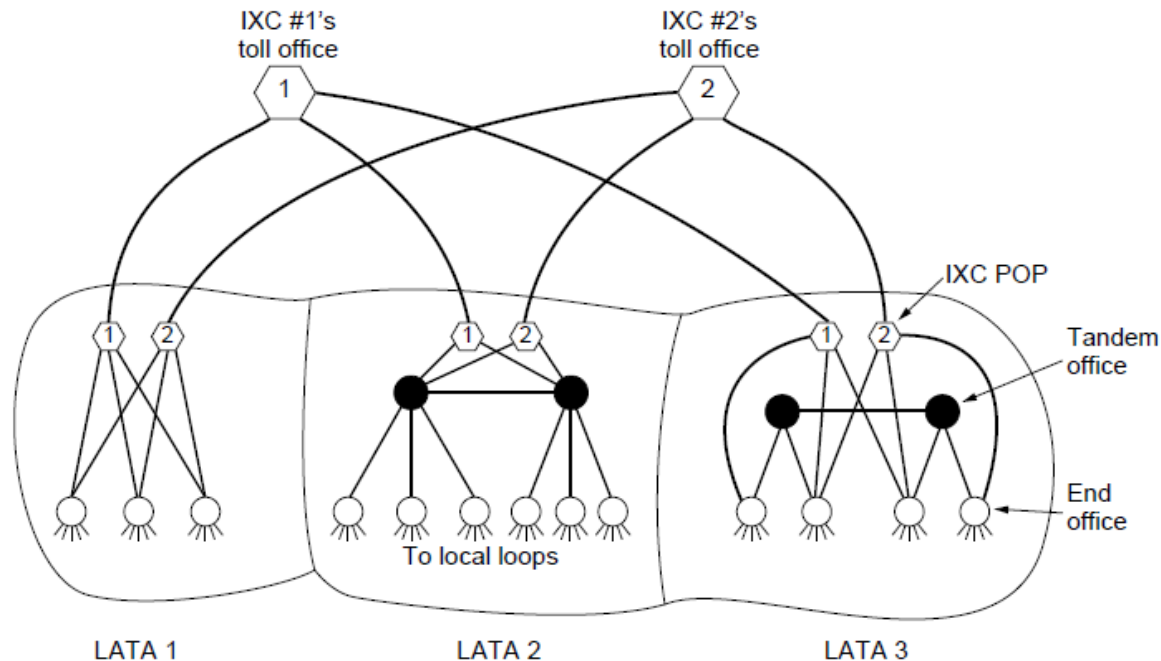

The Politics of Telephones

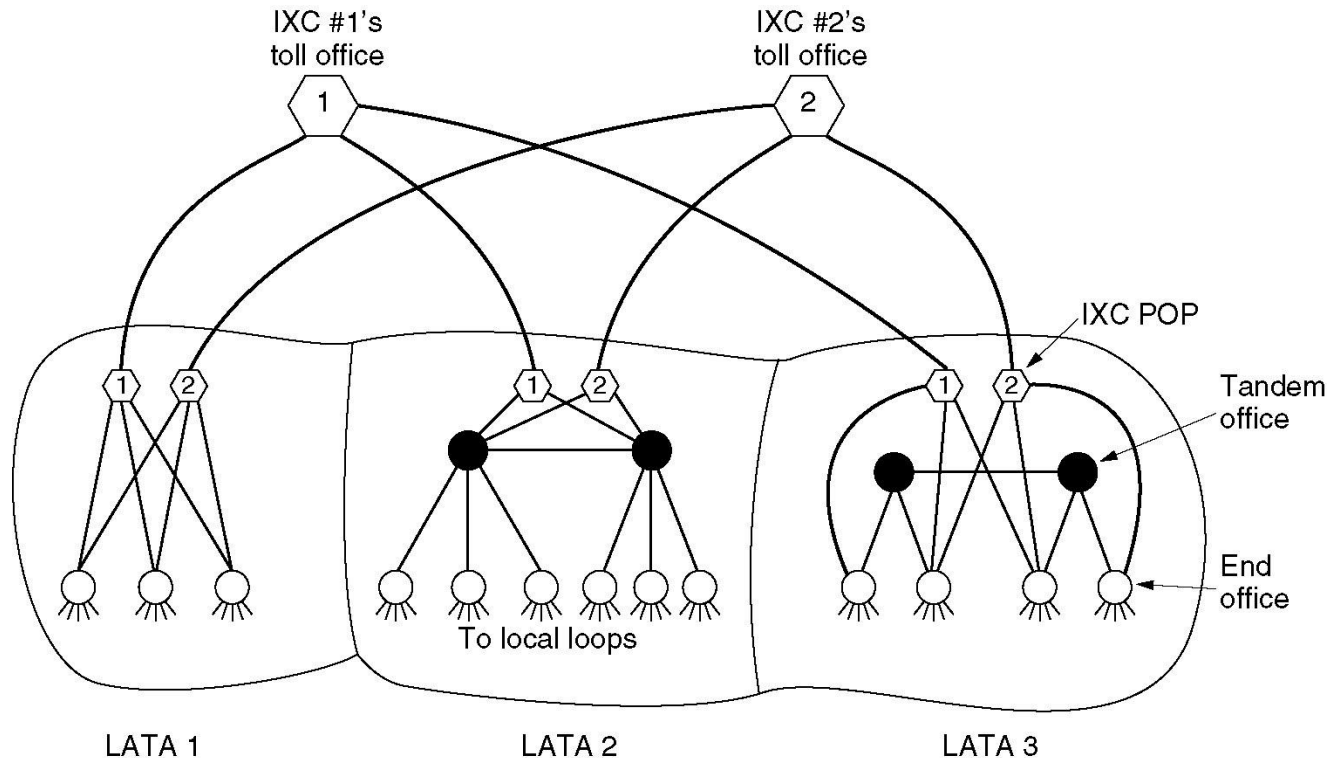

The relationship of LATAs, LECs, and IXCs. All the circles are LEC switching offices. Each hexagon belongs to the IXC whose number is on it.

Major Components of the Telephone System

- Local loops
 - Analog twisted pairs going to houses and businesses
- Trunks
 - Digital fiber optics connecting the switching offices
- Switching offices
 - Where calls are moved from one trunk to another

Local loop (2): Digital Subscriber Lines

DSL broadband sends data over the local loop to the local office using frequencies that are not used for POTS

- Telephone/computer s attach to the same old phone line
- Rates vary with line
 - ADSL2 up to 12 Mbps
- OFDM is used up to 1.1 MHz for ADSL2
 - Most bandwidth down

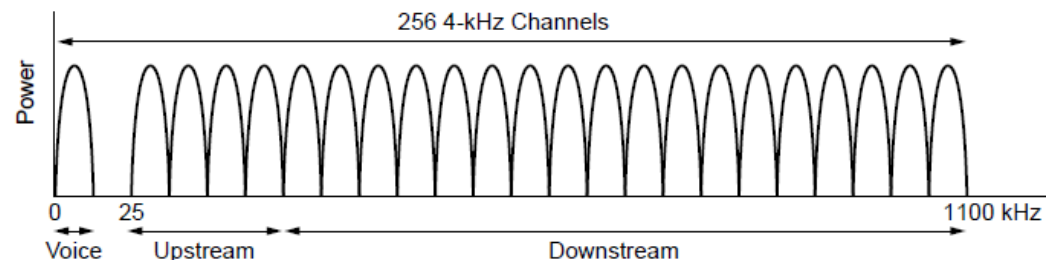
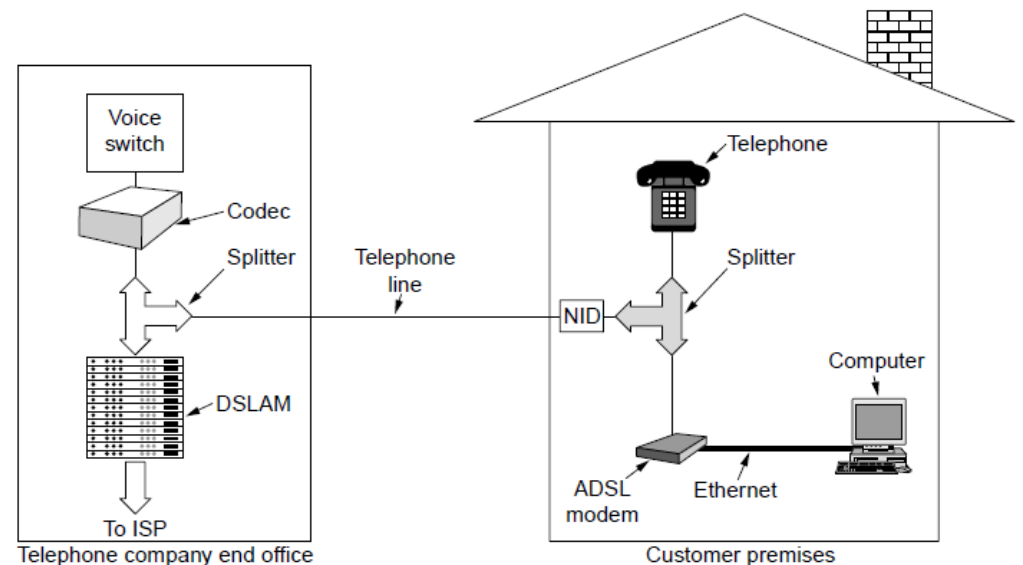

Local loop (3): Fiber To The Home

FTTH broadband relies on deployment of fiber optic cables to provide high data rates customers

- One wavelength can be shared among many houses
- Fiber is passive (no amplifiers, etc.)

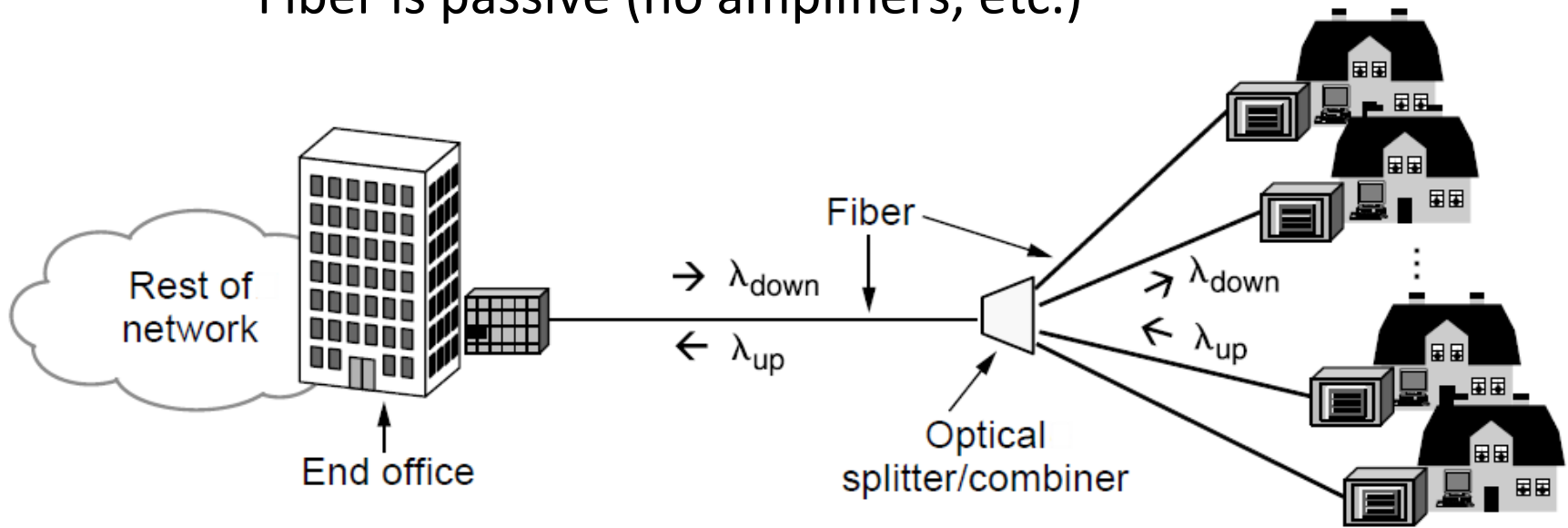

The Local Loop: Modems, ADSL, and Wireless

The use of both analog and digital transmissions for a computer to computer call. Conversion is done by the modems and codecs.

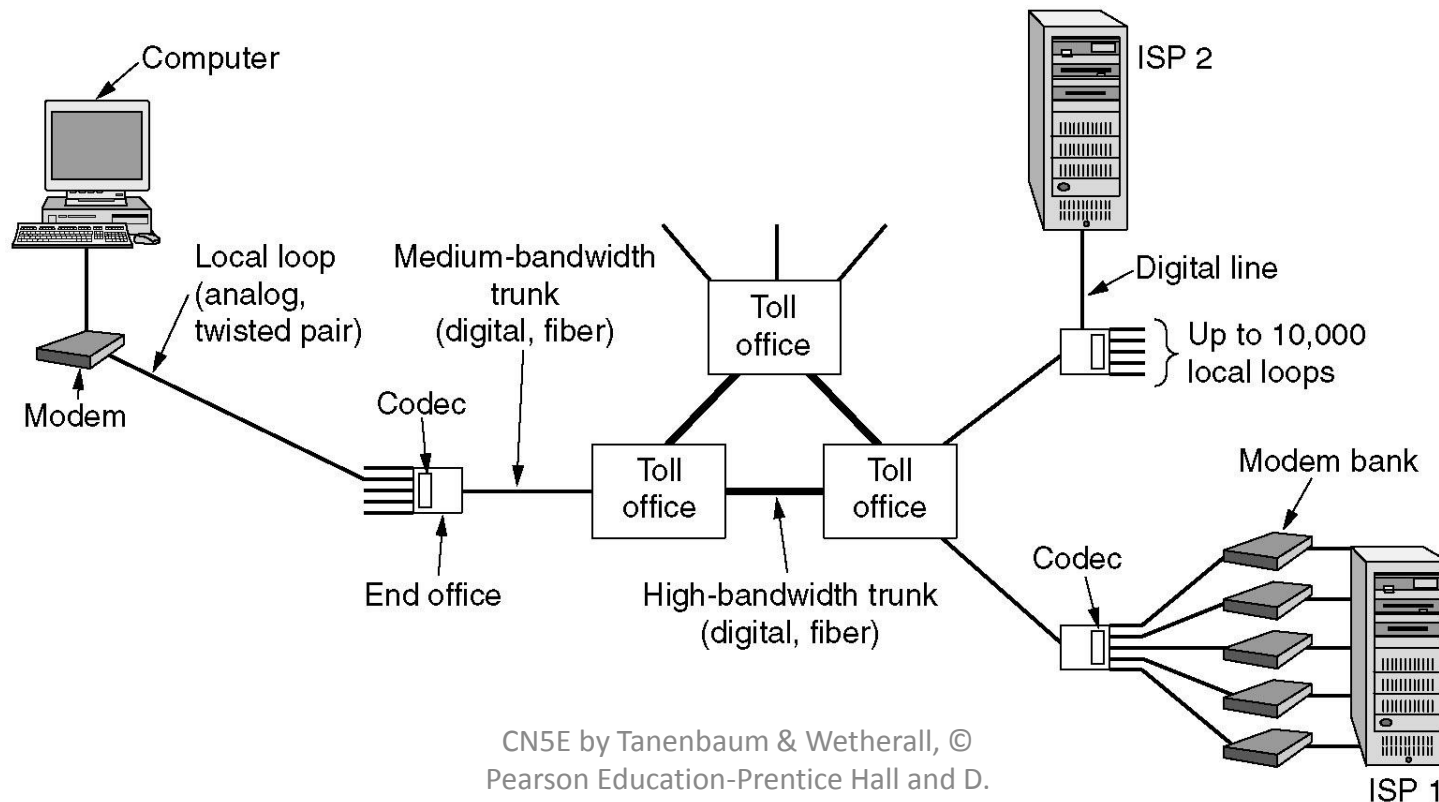

Digital Subscriber Lines

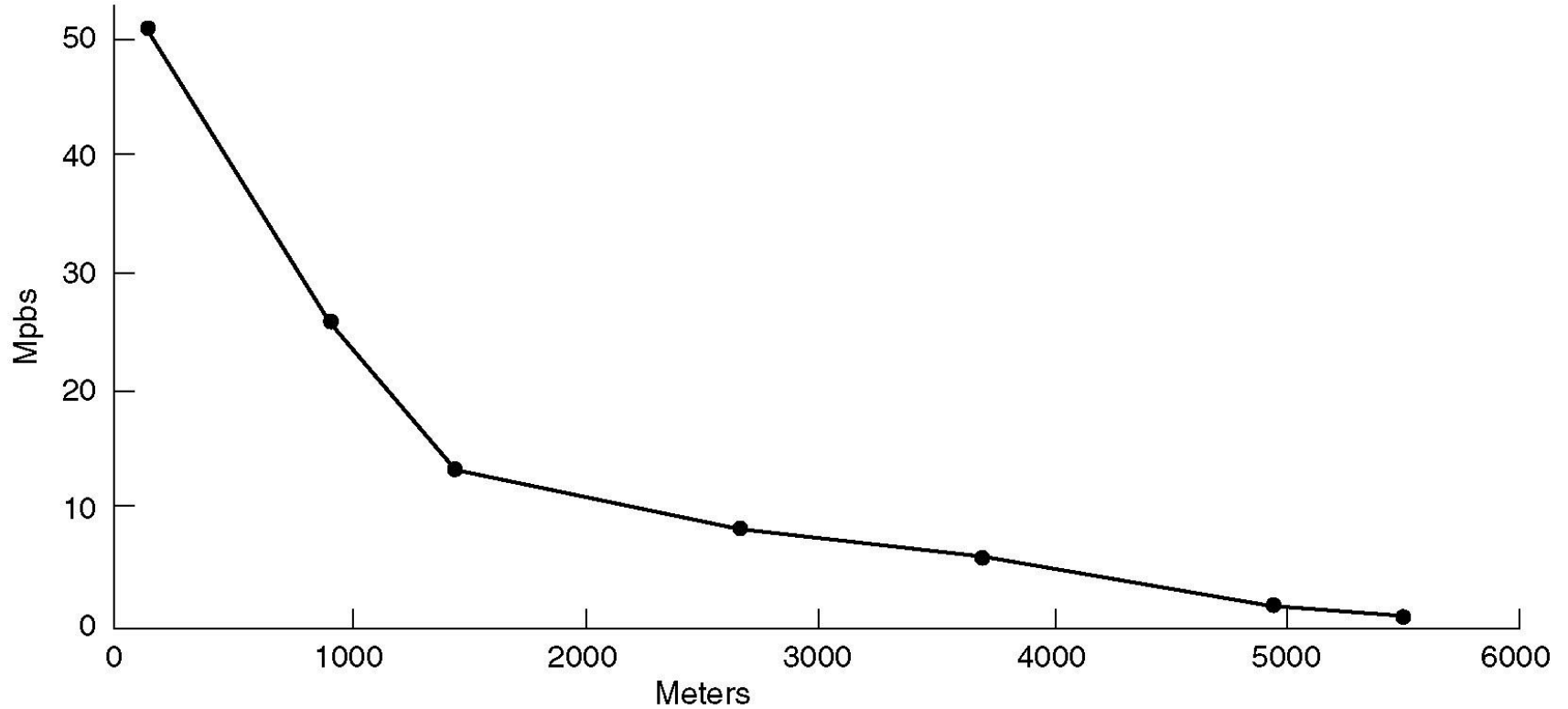

Digital Subscriber Lines (2)

Operation of ADSL using discrete multitone

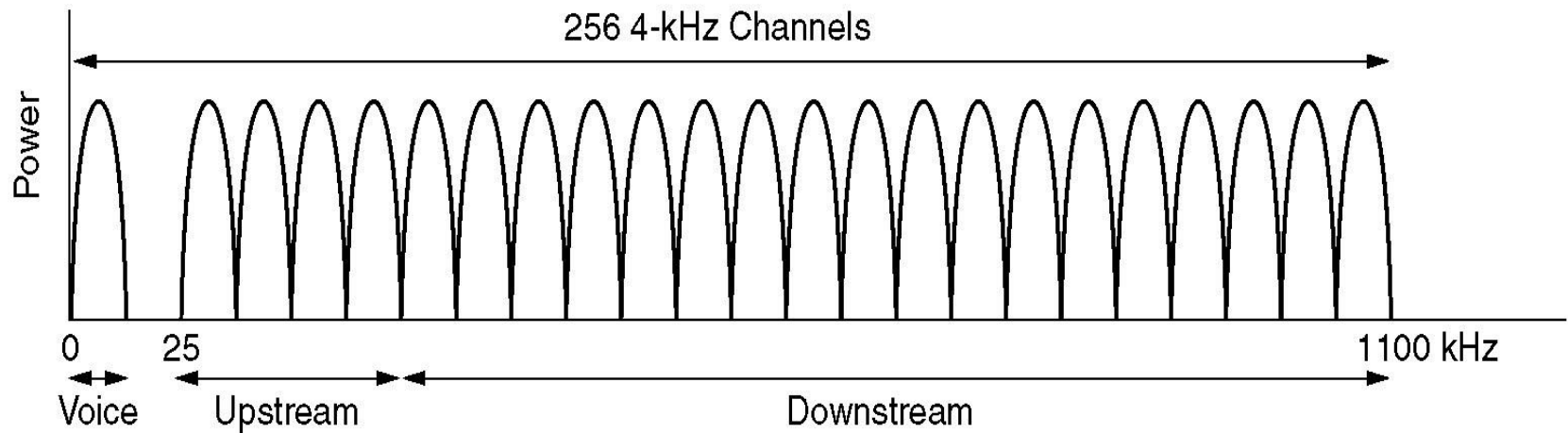

Digital Subscriber Lines (3)

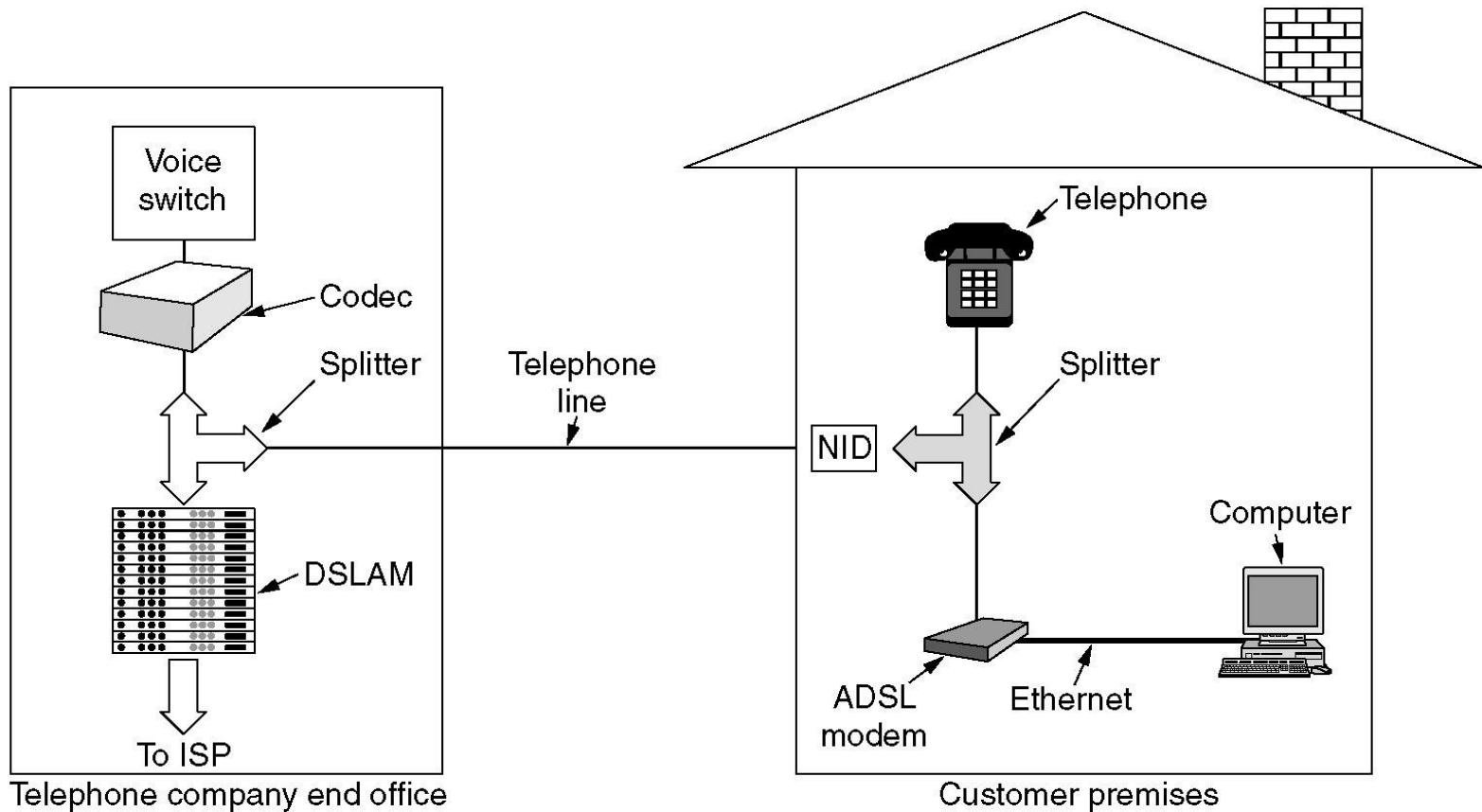

Wireless Local Loops

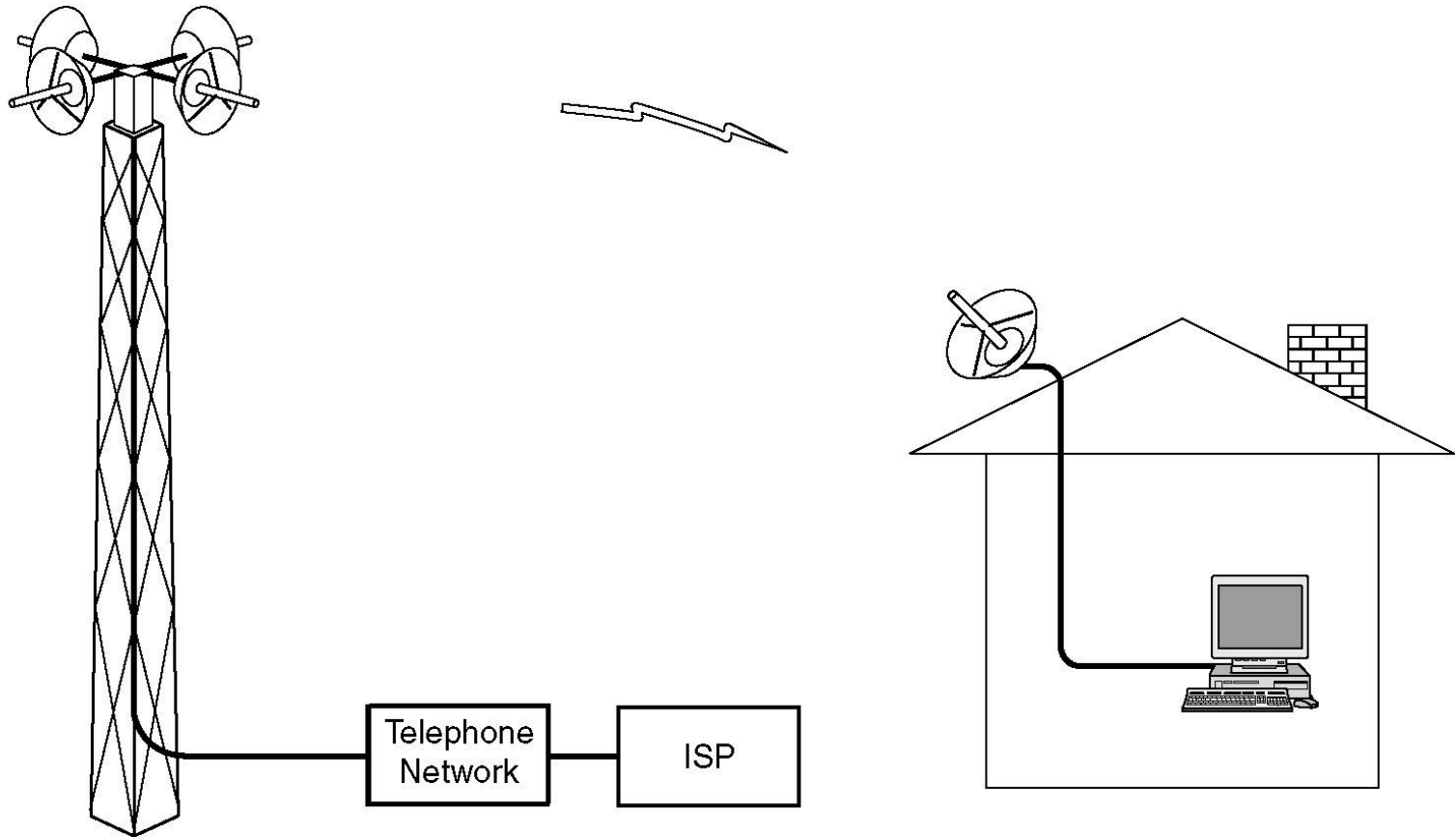

Architecture of an LMDS system.

CN5E by Tanenbaum & Wetherall, ©
Pearson Education-Prentice Hall and D.
Wetherall, 2011

Fiber To The Home

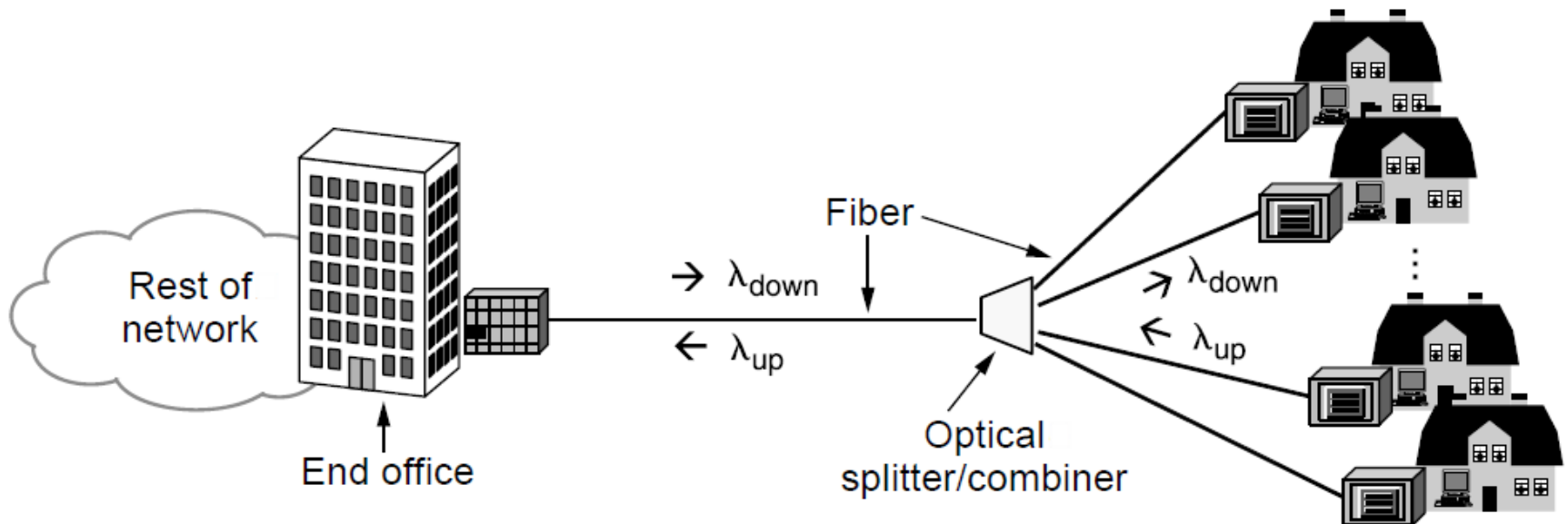

Passive optical network for Fiber To The Home.

Trunks and Multiplexing (1)

Calls are carried digitally on PSTN trunks using TDM

- A call is an 8-bit PCM sample each 125 μ s (64 kbps)
- Traditional T1 carrier has 24 call channels each 125 μ s (1.544 Mbps) with symbols based on AMI

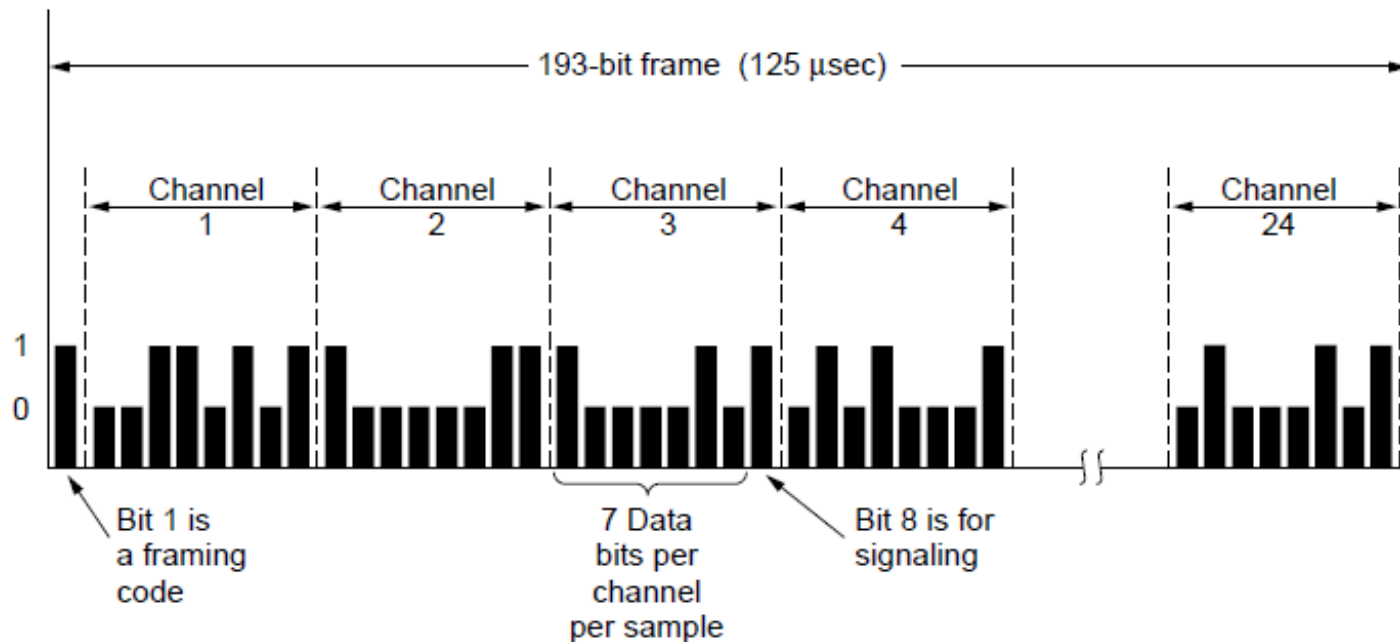

Time Division Multiplexing (2)

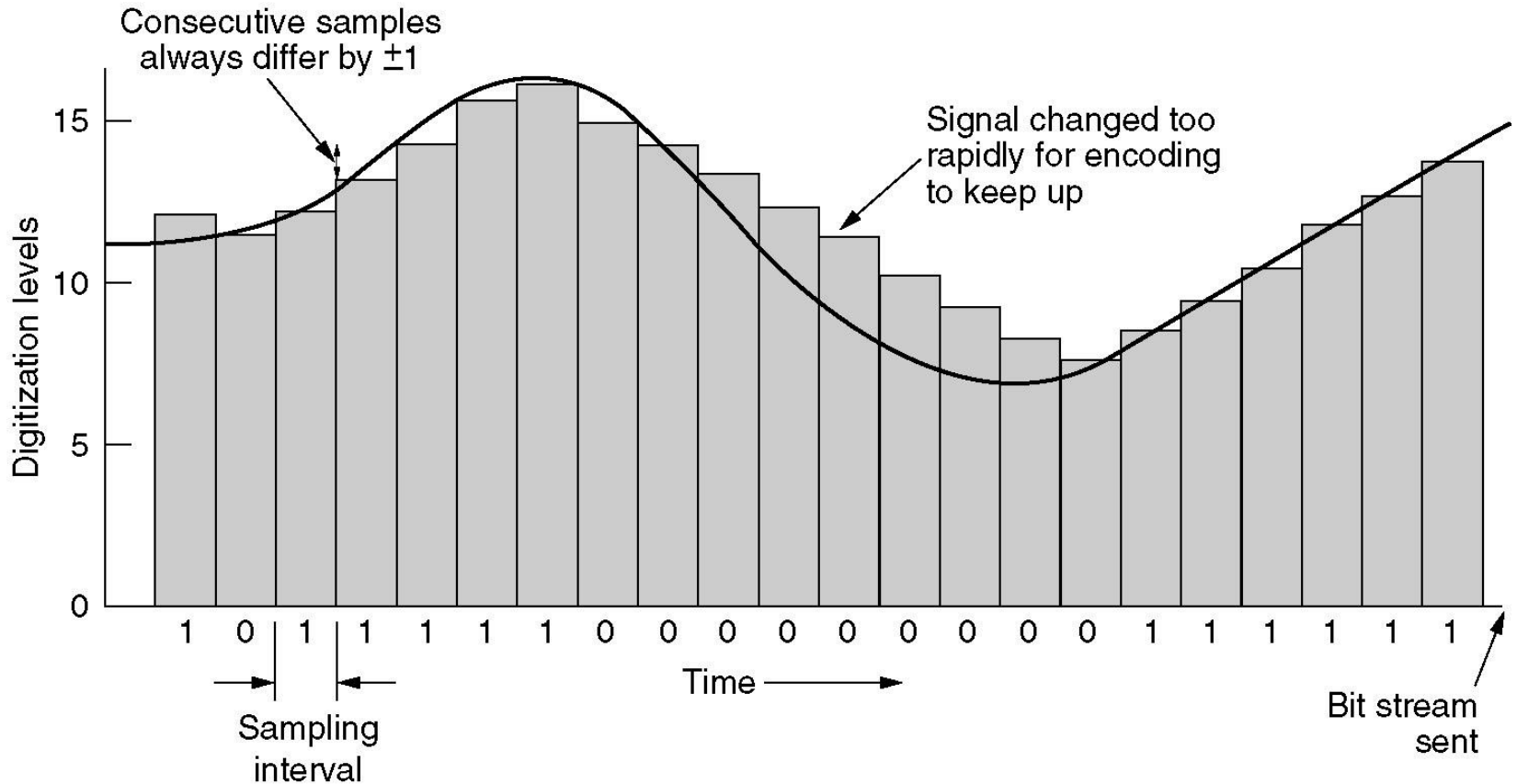

Time Division Multiplexing (3)

Multiplexing T1 streams into higher carriers.

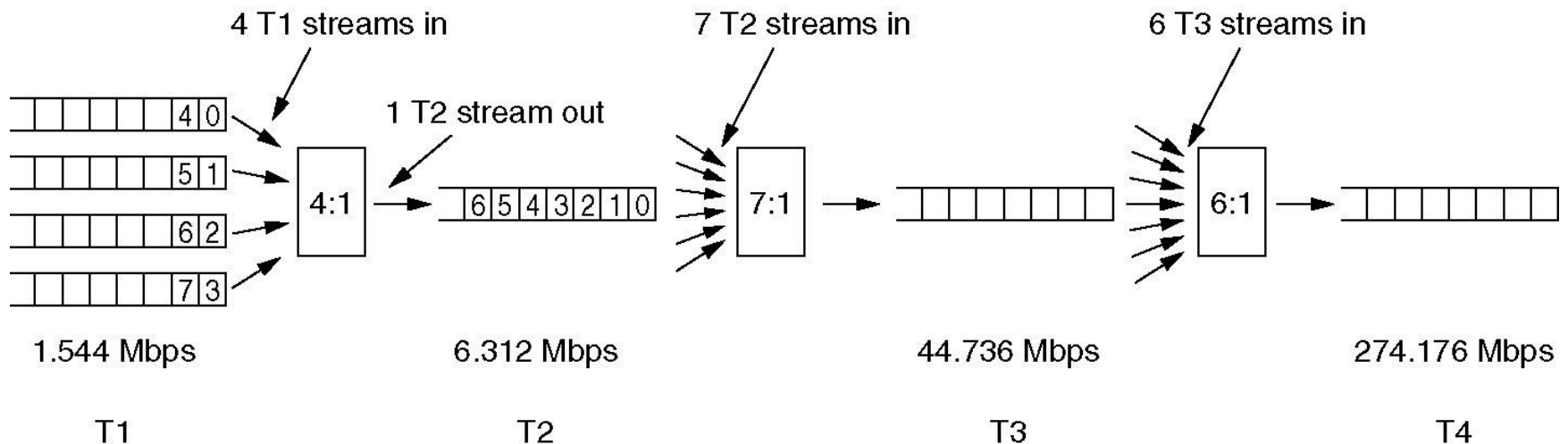

Time Division Multiplexing (4)

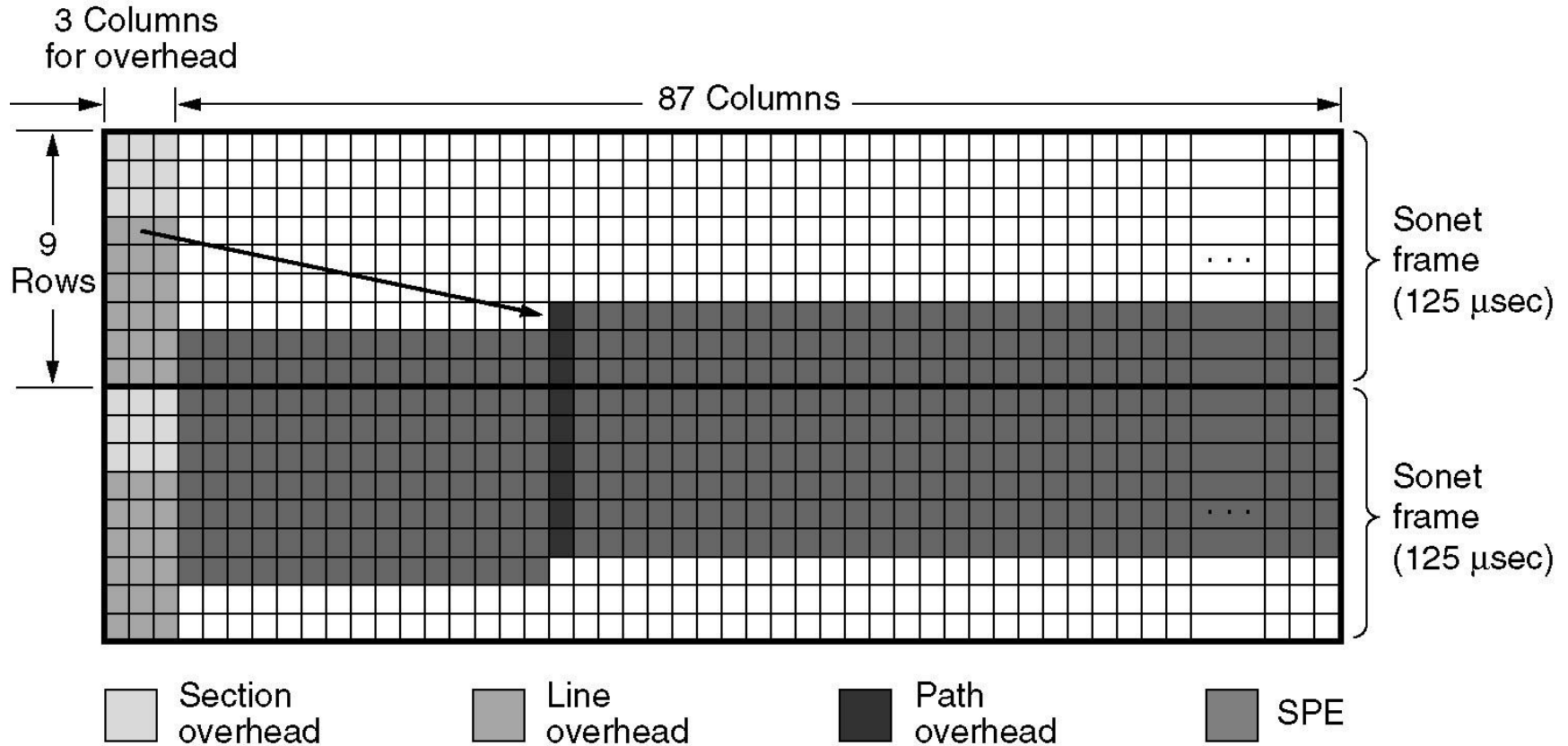

Time Division Multiplexing (5)

SONET		SDH	Data rate (Mbps)		
Electrical	Optical	Optical	Gross	SPE	User
STS-1	OC-1		51.84	50.112	49.536
STS-3	OC-3	STM-1	155.52	150.336	148.608
STS-9	OC-9	STM-3	466.56	451.008	445.824
STS-12	OC-12	STM-4	622.08	601.344	594.432
STS-18	OC-18	STM-6	933.12	902.016	891.648
STS-24	OC-24	STM-8	1244.16	1202.688	1188.864
STS-36	OC-36	STM-12	1866.24	1804.032	1783.296
STS-48	OC-48	STM-16	2488.32	2405.376	2377.728
STS-192	OC-192	STM-64	9953.28	9621.504	9510.912

Wavelength Division Multiplexing

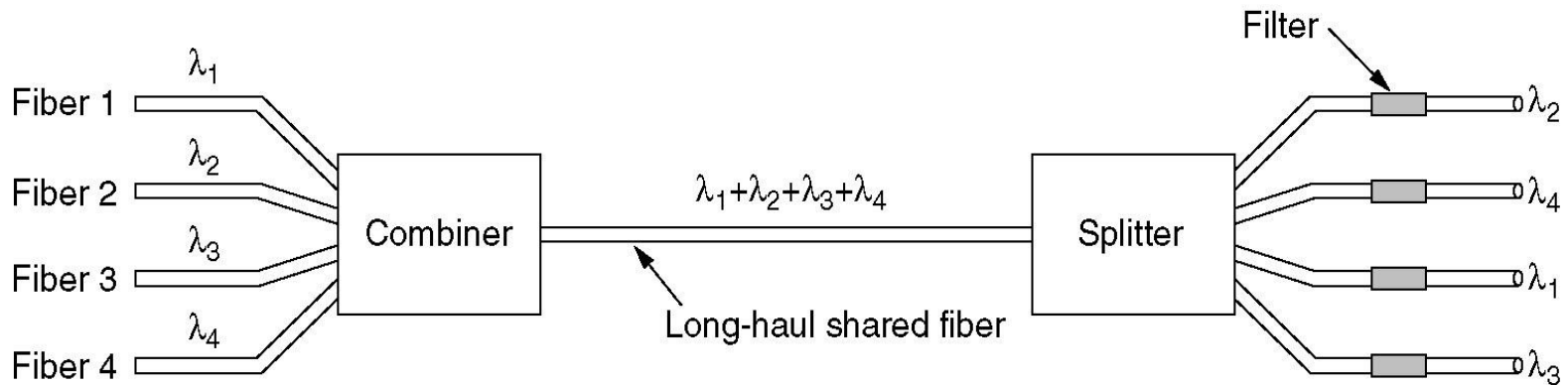
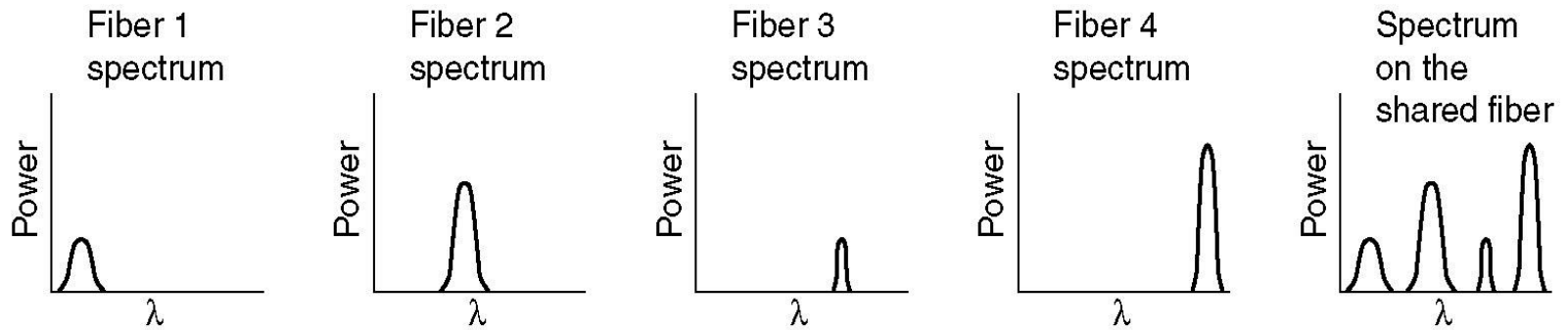

Switching (1)

- PSTN uses circuit switching: Internet uses packet switching

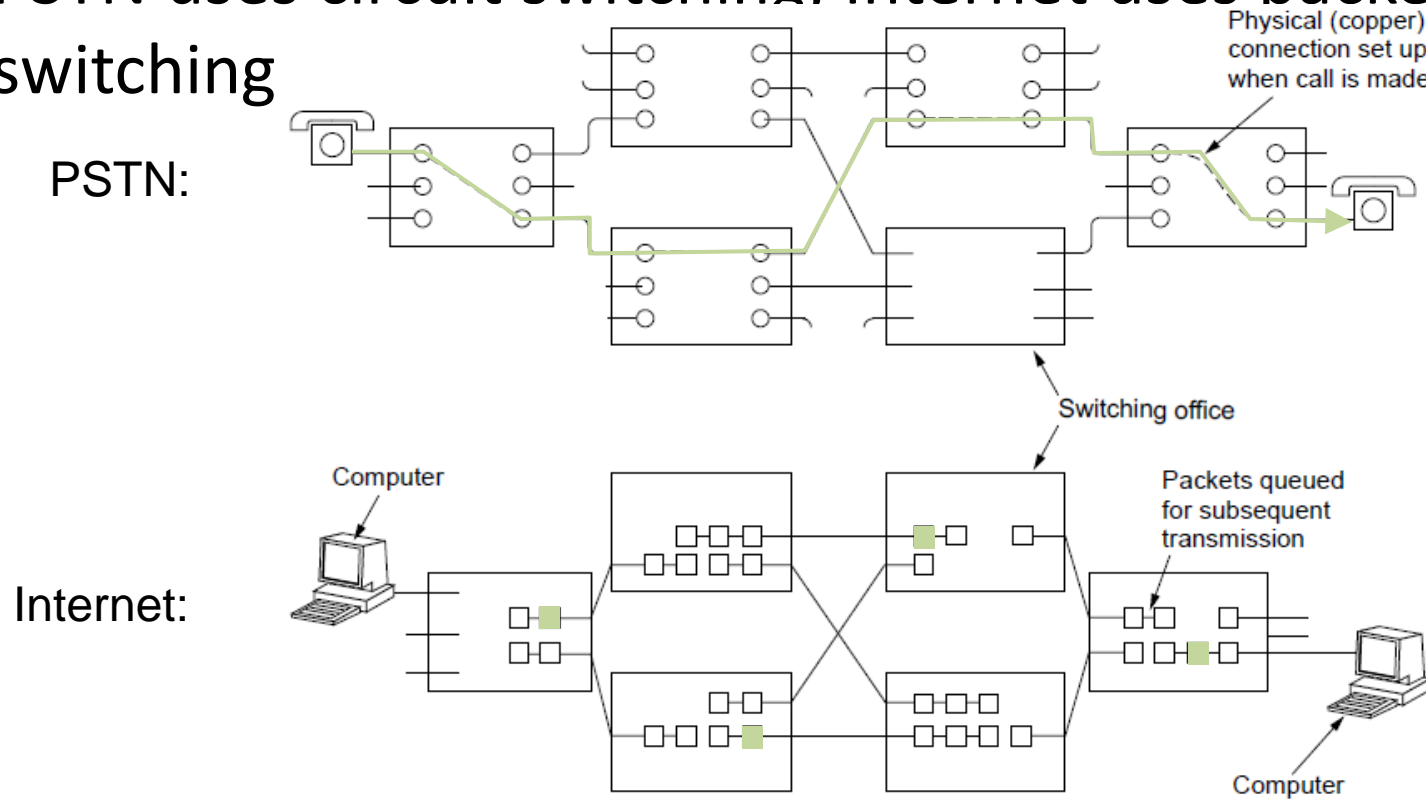

Switching (2)

Circuit switching
requires call setup
(connection) before
data flows smoothly

- Also teardown at end
(not shown)

Packet switching treats
messages
independently

- No setup, but variable
queuing delay at routers

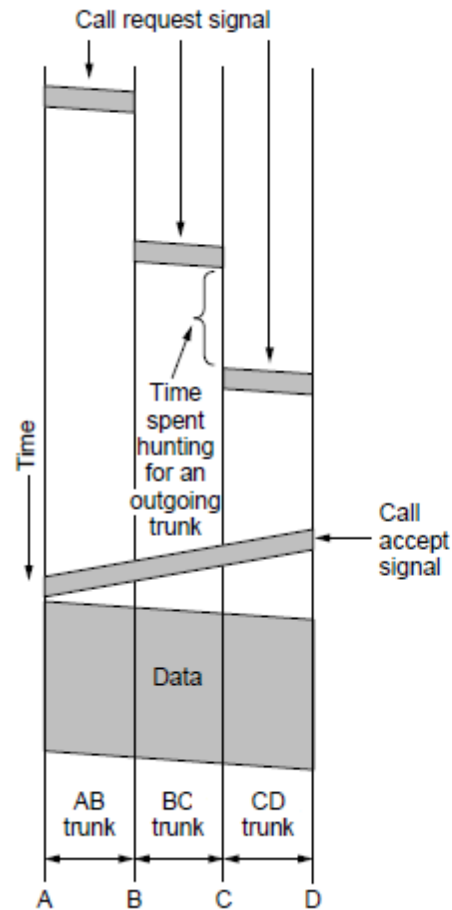

Circuits

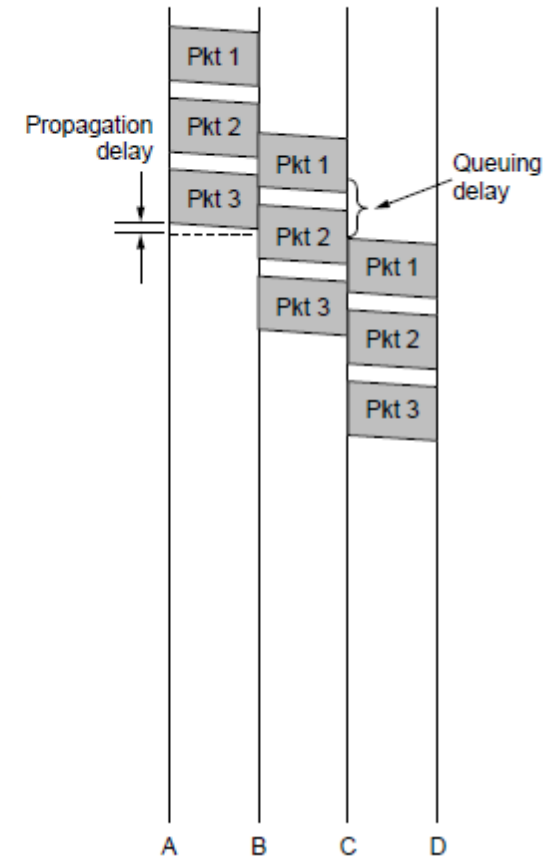

Packets

Message Switching

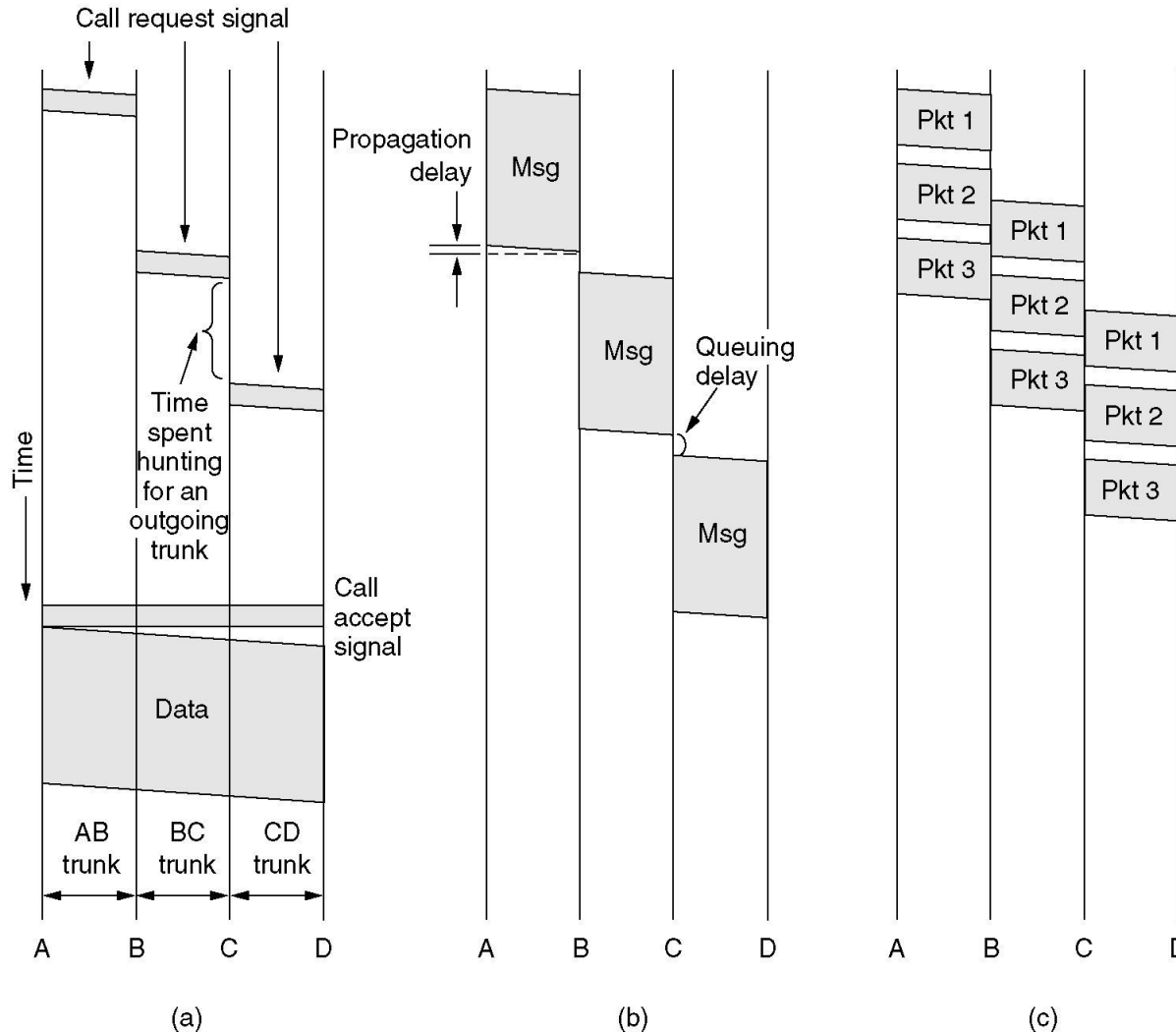

(a) Circuit switching (b) Message switching (c) Packet switching

CM5E by Tanenbaum & Wetherall, © Pearson Education-Prentice Hall and ©

Packet Switching

Item	Circuit-switched	Packet-switched
Call setup	Required	Not needed
Dedicated physical path	Yes	No
Each packet follows the same route	Yes	No
Packets arrive in order	Yes	No
Is a switch crash fatal	Yes	No
Bandwidth available	Fixed	Dynamic
When can congestion occur	At setup time	On every packet
Potentially wasted bandwidth	Yes	No
Store-and-forward transmission	No	Yes
Transparency	Yes	No
Charging	Per minute	Per packet

A comparison of circuit switched and packet-switched networks.

Mobile Telephone System

- Generations of mobile telephone systems »
- Cellular mobile telephone systems »
- GSM, a 2G system »
- UMTS, a 3G system »

Generations of mobile telephone systems

1G, analog voice

- AMPS (Advanced Mobile Phone System) is example, deployed from 1980s. Modulation based on FM (as in radio).

2G, analog voice and digital data

- GSM (Global System for Mobile communications) is example, deployed from 1990s. Modulation based on QPSK.

3G, digital voice and data

- UMTS (Universal Mobile Telecommunications System) is example, deployed from 2000s. Modulation based on CDMA

4G, digital data including voice

- LTE (Long Term Evolution) is example, deployed from 2010s. Modulation based on OFDM

Cellular mobile phone systems

All based on notion of spatial regions called cells

- Each mobile uses a frequency in a cell; moves cause handoff
- Frequencies are reused across non-adjacent cells
- To support more mobiles, smaller cells can be used

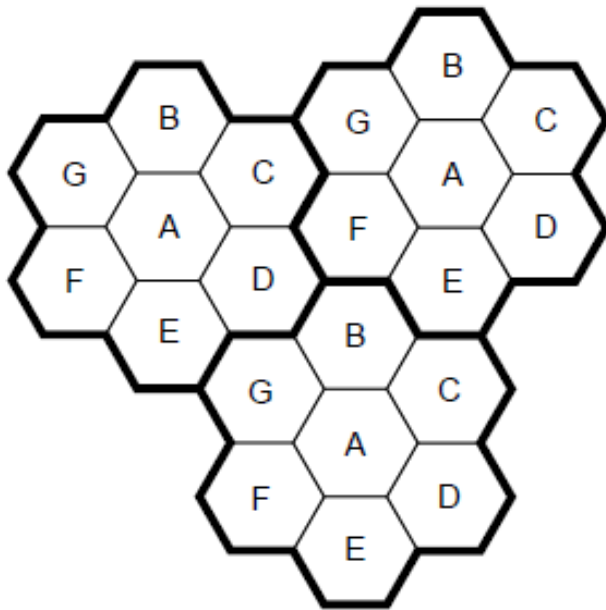

Cellular reuse pattern

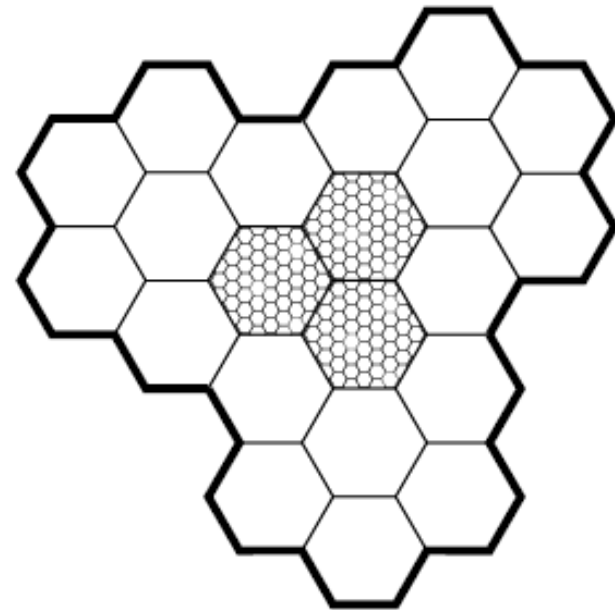

Smaller cells for dense mobiles

Channel Categories

The 832 channels are divided into four categories:

- Control (base to mobile) to manage the system
- Paging (base to mobile) to alert users to calls for them
- Access (bidirectional) for call setup and channel assignment
- Data (bidirectional) for voice, fax, or data

D-AMPS

Digital Advanced Mobile Phone System

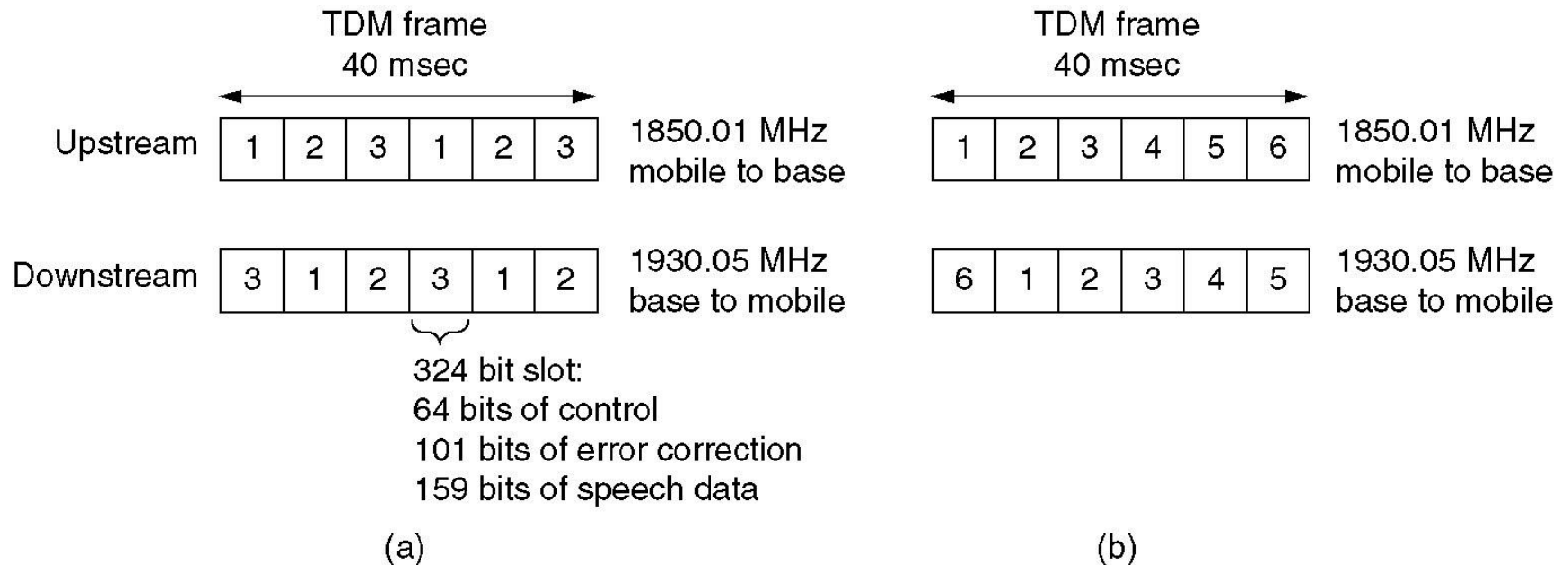

(a) A D-AMPS channel with three users.

(b) A D-AMPS channel with six users.

GSM – Global System for Mobile Communications (1)

- Mobile is divided into handset and SIM card (Subscriber Identity Module) with credentials
- Mobiles tell their HLR (Home Location Register) their current whereabouts for incoming calls
- Cells keep track of visiting mobiles (in the Visitor LR)

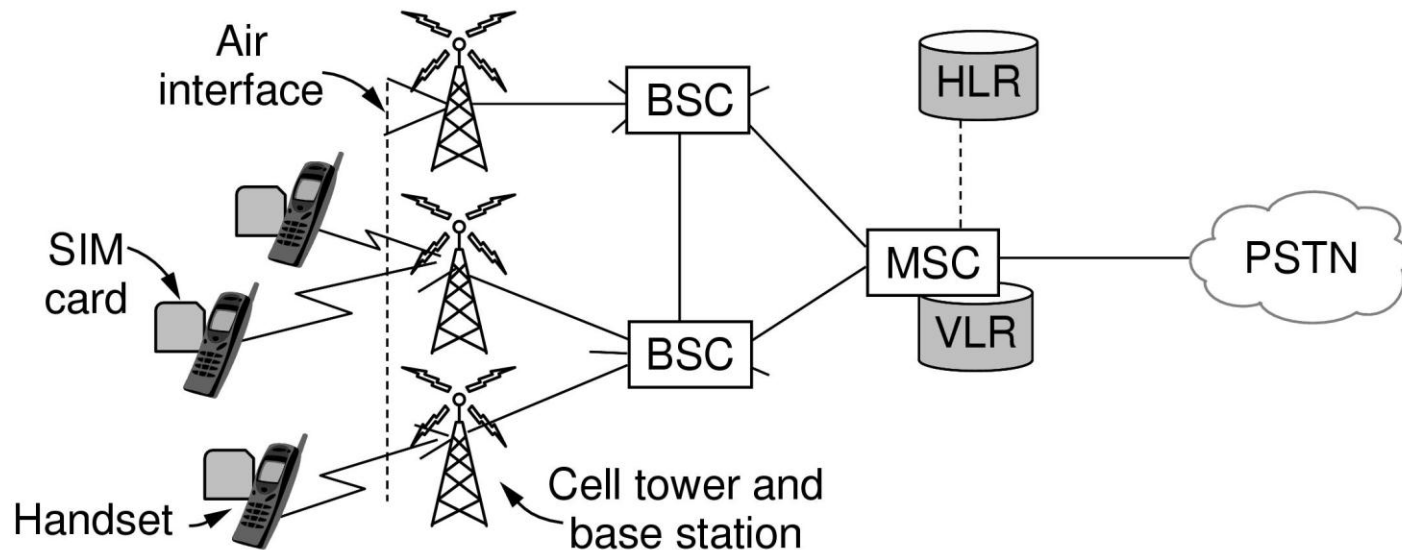

GSM – Global System for Mobile Communications (2)

Air interface is based on FDM channels of 200 KHz divided in an eight-slot TDM frame every 4.615 ms

- Mobile is assigned up- and down-stream slots to use
- Each slot is 148 bits long, gives rate of 27.4 kbps

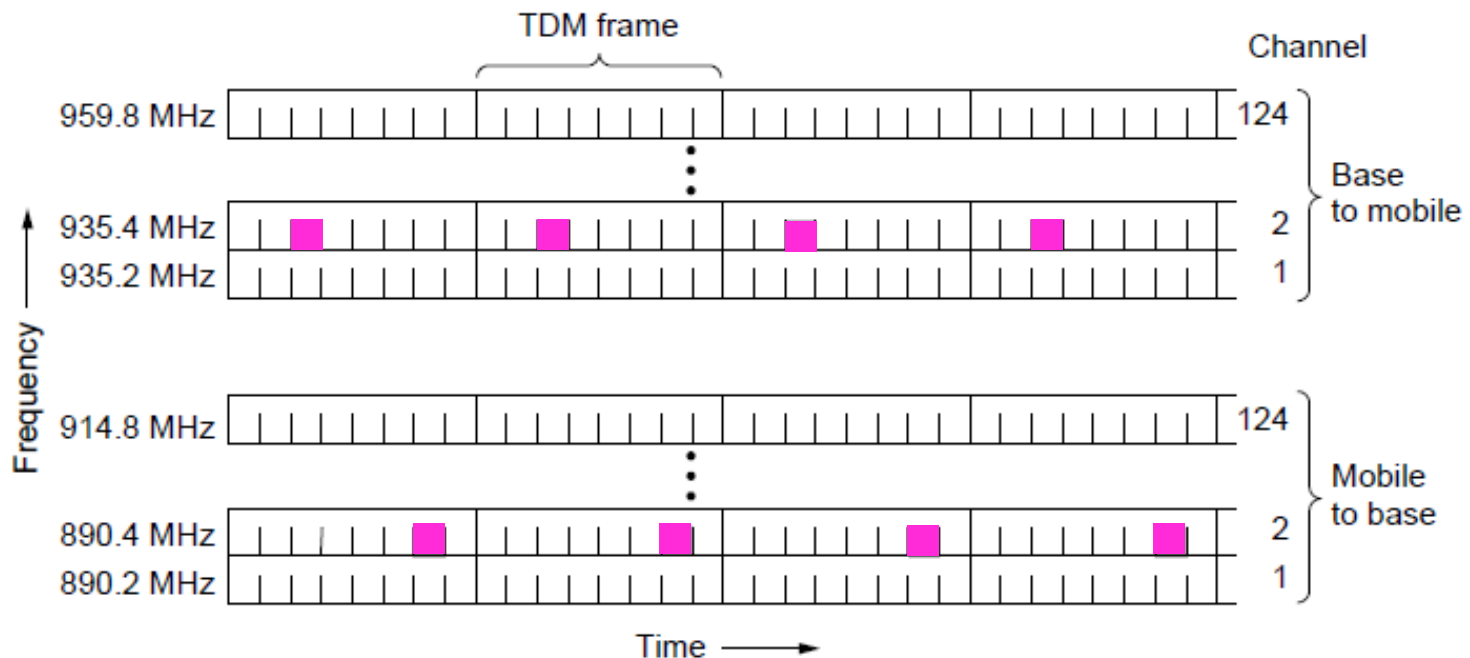

GSM (2)

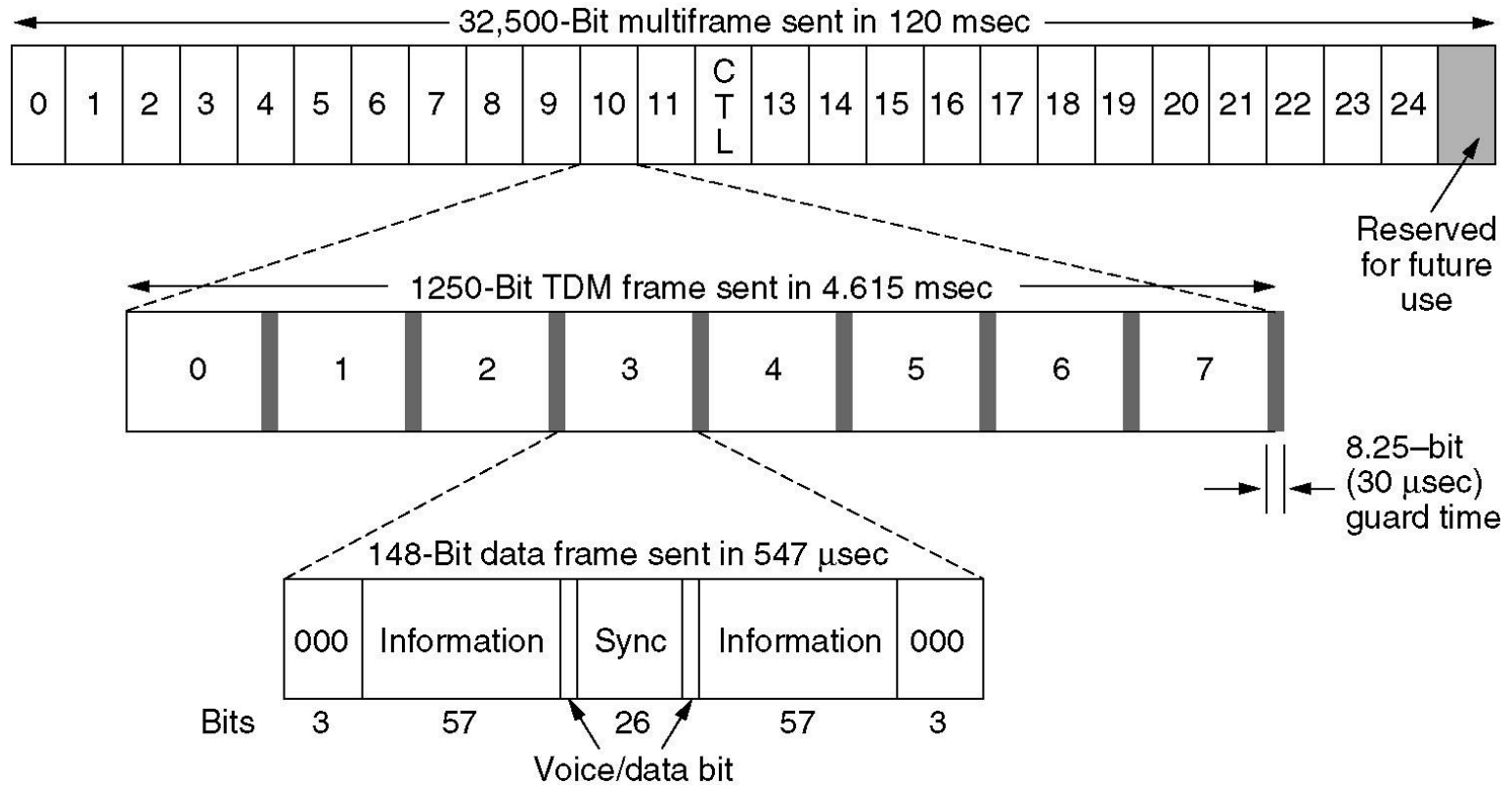

UMTS – Universal Mobile Telecommunications System (1)

Architecture is an evolution of GSM; terminology differs
Packets goes to/from the Internet via SGSN/GGSN

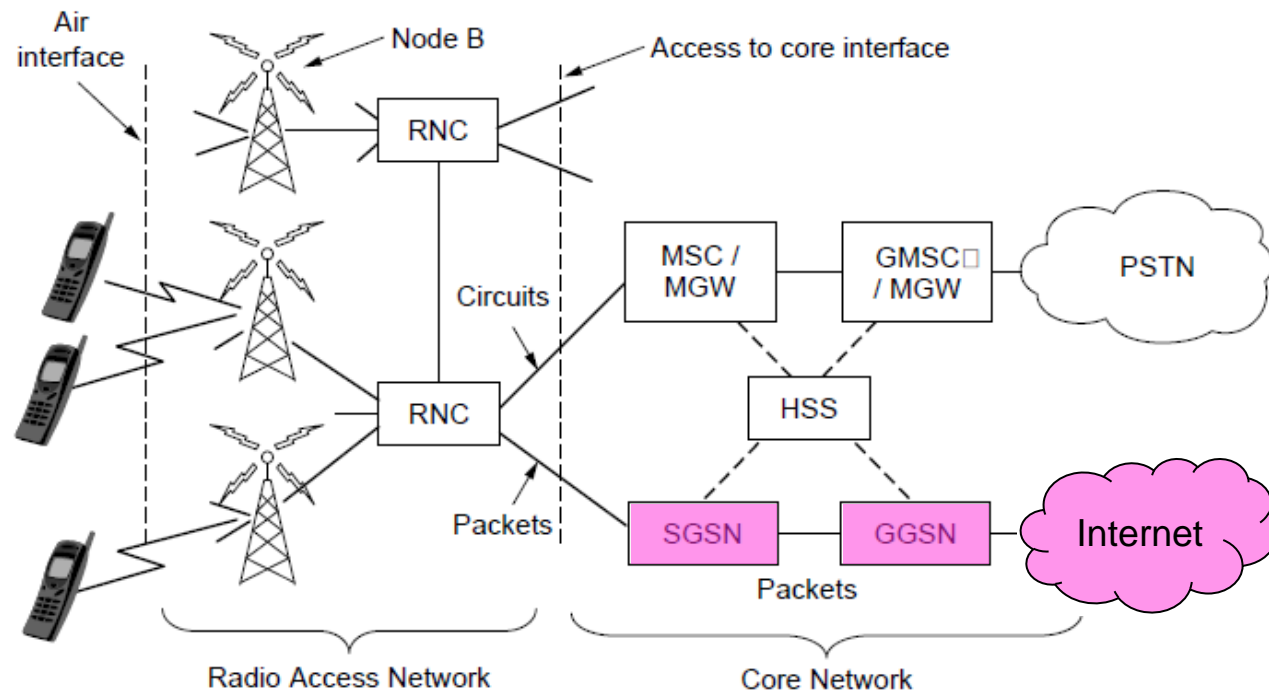

CDMA – Code Division Multiple Access

A: 0 0 0 1 1 0 1 1
 B: 0 0 1 0 1 1 1 0
 C: 0 1 0 1 1 1 0 0
 D: 0 1 0 0 0 0 1 0

(a)

A: (-1 -1 -1 +1 +1 -1 +1 +1)
 B: (-1 -1 +1 -1 +1 +1 +1 -1)
 C: (-1 +1 -1 +1 +1 +1 -1 -1)
 D: (-1 +1 -1 -1 -1 -1 +1 -1)

(b)

Six examples:

-- 1 --	C	$S_1 = (-1 +1 -1 +1 +1 +1 -1 -1)$
- 1 1 -	B + C	$S_2 = (-2 0 0 0 +2 +2 0 -2)$
1 0 --	A + B	$S_3 = (0 0 -2 +2 0 -2 0 +2)$
1 0 1 -	A + B + C	$S_4 = (-1 +1 -3 +3 +1 -1 -1 +1)$
1 1 1 1	A + B + C + D	$S_5 = (-4 0 -2 0 +2 0 +2 -2)$
1 1 0 1	A + B + C + D	$S_6 = (-2 -2 0 -2 0 -2 +4 0)$

(c)

$S_1 \cdot C = (1 +1 +1 +1 +1 +1 +1 +1)/8 = 1$
 $S_2 \cdot C = (2 +0 +0 +0 +2 +2 +0 +2)/8 = 1$
 $S_3 \cdot C = (0 +0 +2 +2 +0 -2 +0 -2)/8 = 0$
 $S_4 \cdot C = (1 +1 +3 +3 +1 -1 +1 -1)/8 = 1$
 $S_5 \cdot C = (4 +0 +2 +0 +2 +0 -2 +2)/8 = 1$
 $S_6 \cdot C = (2 -2 +0 -2 +0 -2 -4 +0)/8 = -1$

(d)

- (a) Binary chip sequences for four stations
- (b) Bipolar chip sequences
- (c) Six examples of transmissions
- (d) Recovery of station C's signal

Third-Generation Mobile Phones: Digital Voice and Data

Basic services an IMT-2000 network should provide

- High-quality voice transmission
- Messaging (replace e-mail, fax, SMS, chat, etc.)
- Multimedia (music, videos, films, TV, etc.)
- Internet access (web surfing, w/multimedia.)

Digital Voice and Data (2)

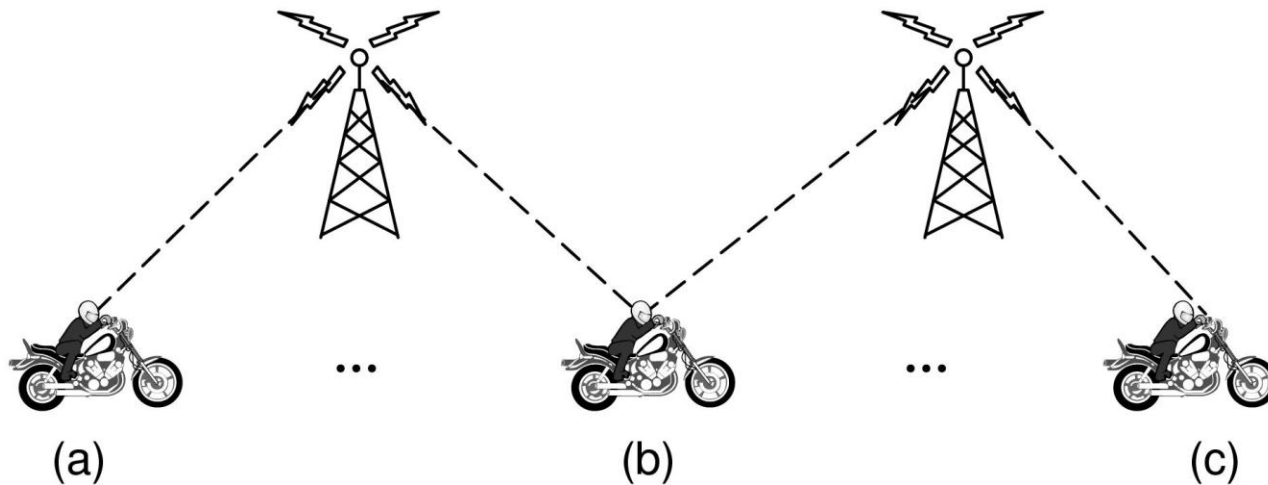

Soft handoff (a) before, (b) during, and (c) after.

Cable Television

- Internet over cable »
- Spectrum allocation »
- Cable modems »
- ADSL vs. cable »

Community Antenna Television

An early cable television system.

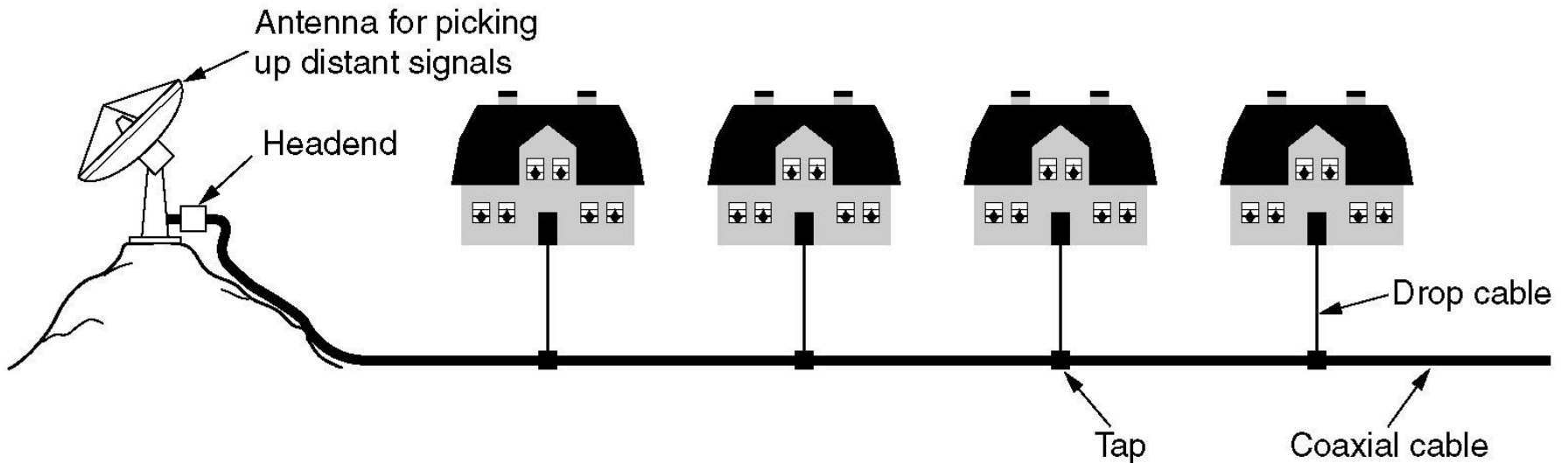

Internet over Cable

Internet over cable reuses the cable television plant

- Data is sent on the shared cable tree from the head-end, not on a dedicated line per subscriber (DSL)

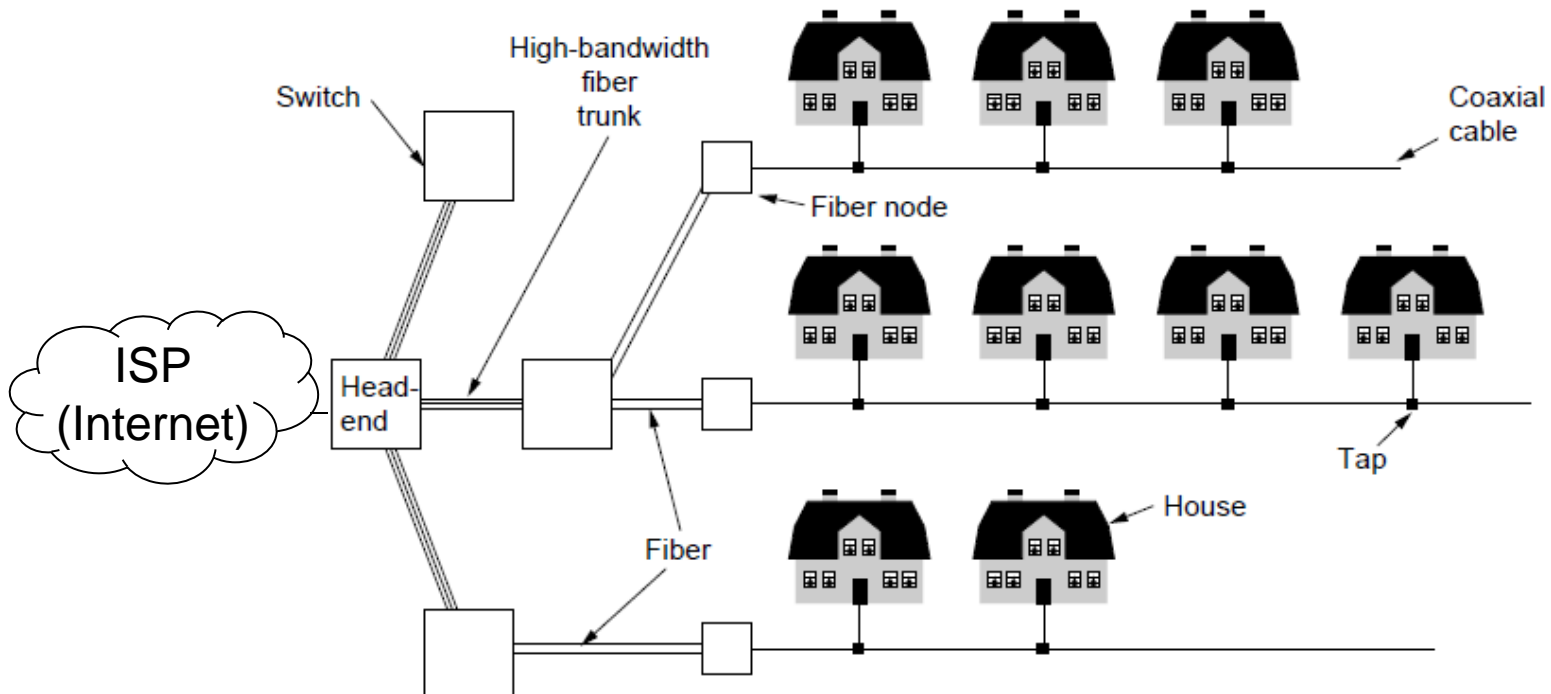

Spectrum Allocation

Upstream and downstream data are allocated to frequency channels not used for TV

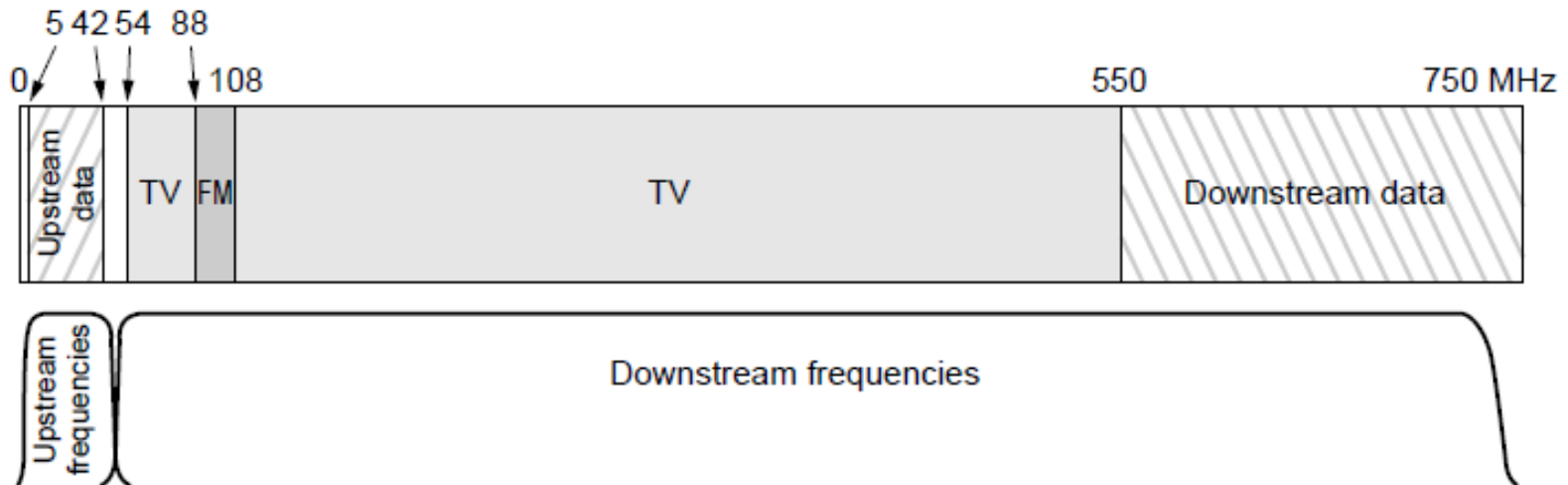

Cable Modems

Cable modems at customer premises implement the physical layer of the DOCSIS standard

- QPSK/QAM is used in timeslots on frequencies that are assigned for upstream/downstream data

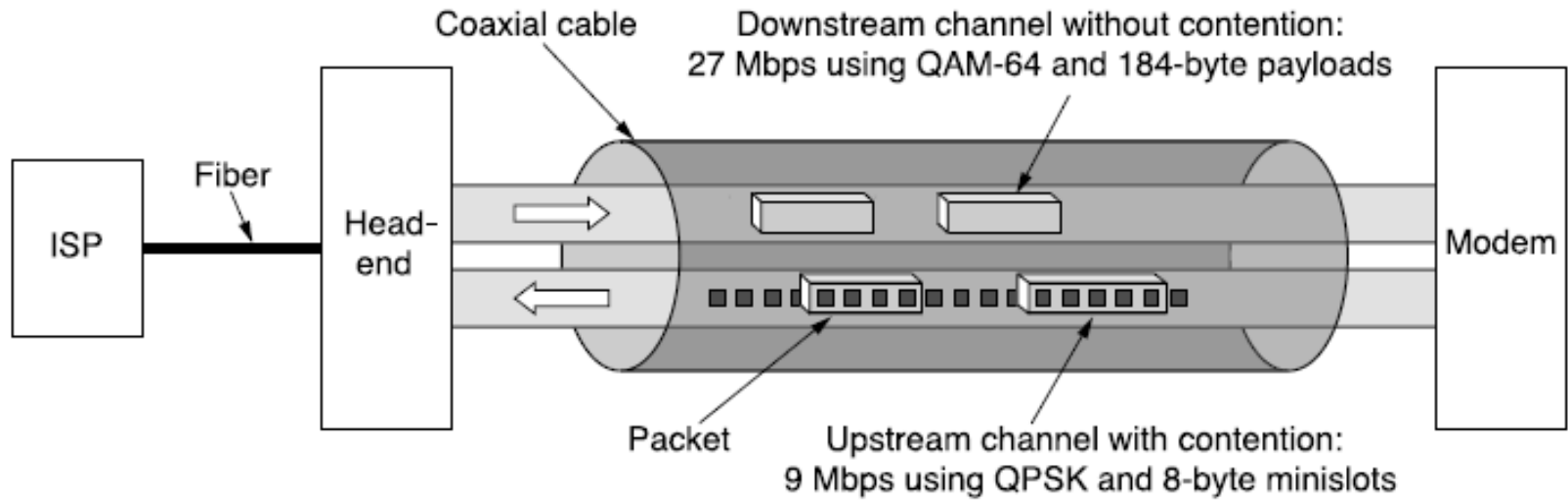

Cable vs. ADSL

Cable:

- + Uses coaxial cable to customers (good bandwidth)
- Data is broadcast to all customers (less secure)
- Bandwidth is shared over customers so may vary

ADSL:

- + Bandwidth is dedicated for each customer
- + Point-to-point link does not broadcast data
- Uses twisted pair to customers (lower bandwidth)

End

Chapter 2