

Questions?

- Project

Asynchronous serial communication

- Key points
 - Data is transmitted one bit at a time
 - *With a start bit and a stop bit*
 - Asynchronous: no clock signal is transmitted
 - Two wires protocol
 - *Transmit line, and receive line*
 - *Need to be crossed over!*
 - Flow control
 - *None*
 - *Hardware*
 - RTS (Request To Send), CTS (Clear To Send);
 - DSR (Data Set Ready), DTR (Data Terminal Ready);
 - *Software protocols such as Xon/Xoff;*

Transmitting

FIGURE 16-2: ASYNCHRONOUS TRANSMISSION

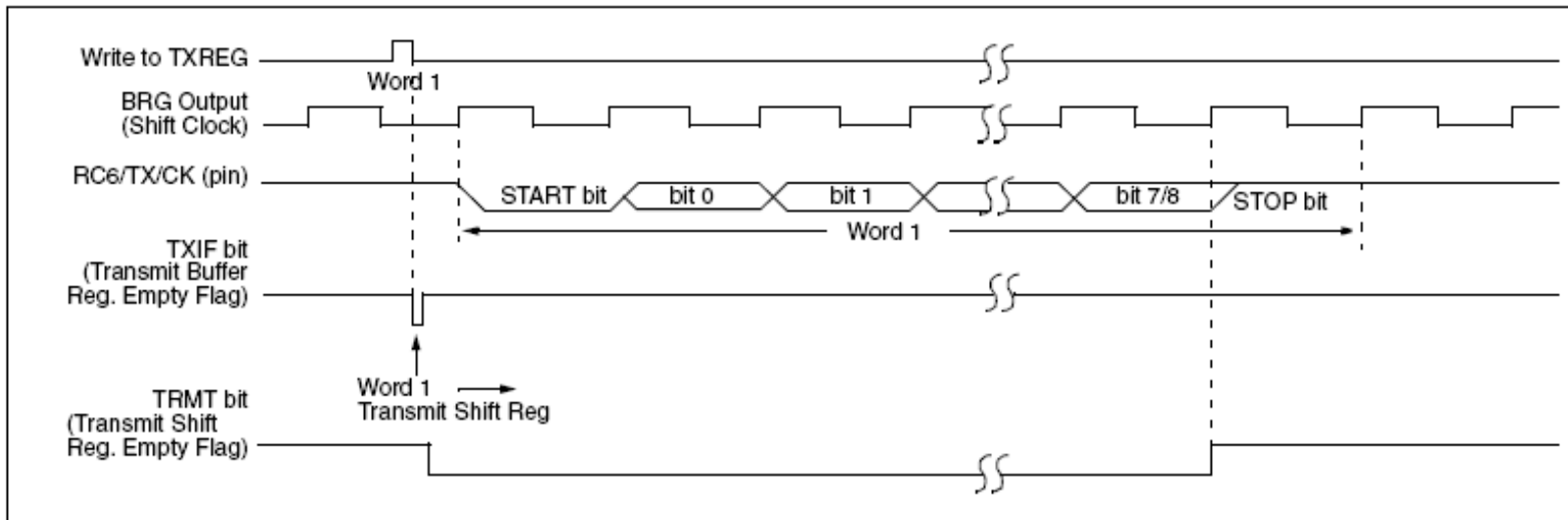
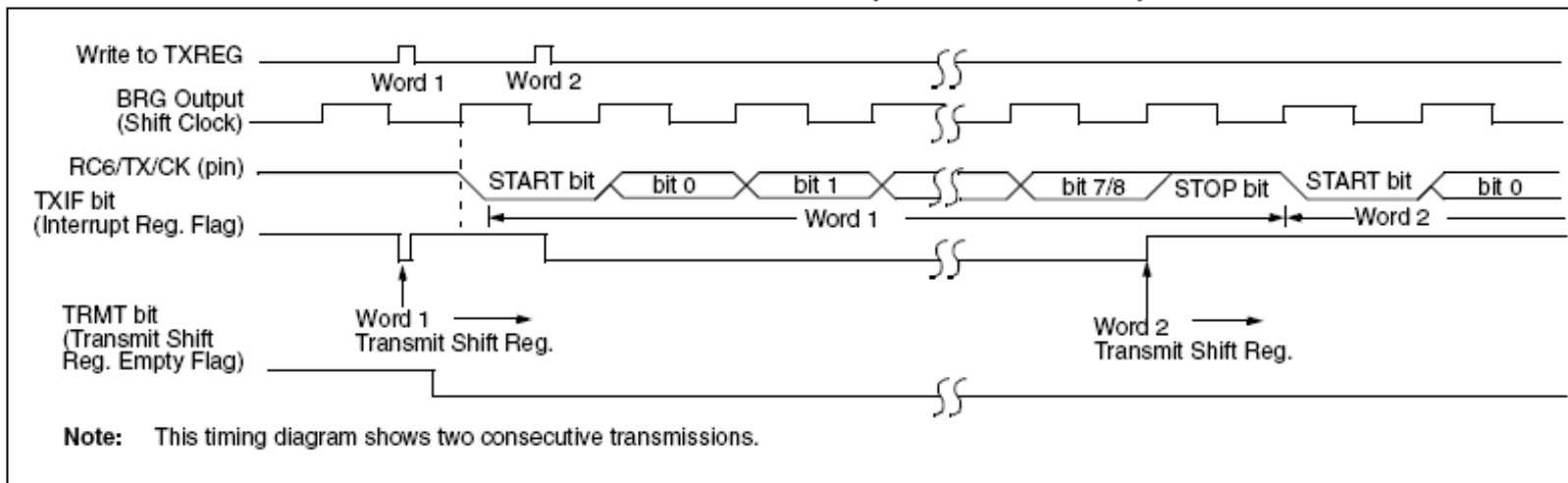
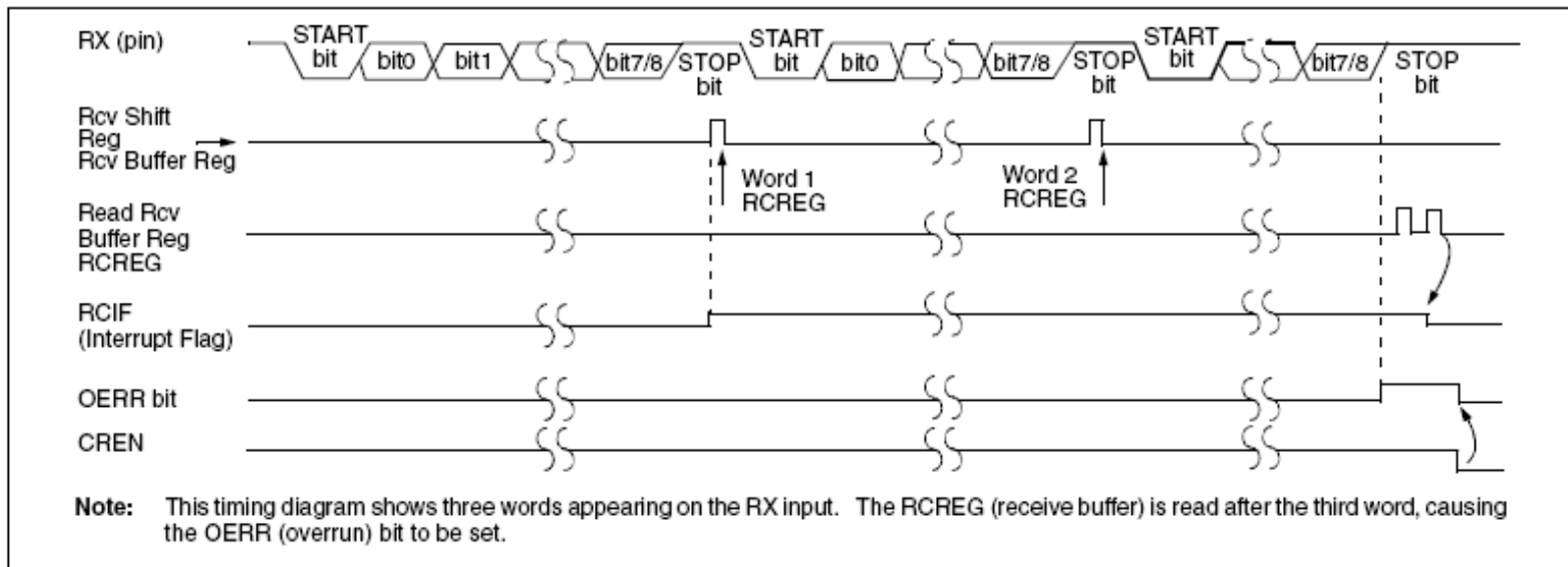

FIGURE 16-3: ASYNCHRONOUS TRANSMISSION (BACK TO BACK)



Receiving

FIGURE 16-5: ASYNCHRONOUS RECEPTION



USART Setting

- To do:
 - Set the port direction (TRISC6 and TRSC7)
 - Select the baud rate (SPBRG)
 - TXSTAbits.BRGH set low/high baud rate
 - Set the unit for Asynchronous communication (TXSTAbits.SYNC)
 - Set the data length (RCSTAbits.RX9 and TXSTAbits.TX9)
 - Enable receiver (RCSTAbits.CREN)
 - Enable transmission (TXSTAbits.TXEN)
 - Enable the serial port (RCSTAbits.SPEN)

Assignment

- Print the current value of the A/D;
- Print the current value of the A/D upon request
 - Using interrupt handling