

# MeshTest: Laboratory-Based Wireless Testbed for Large Topologies

T. Charles Clancy  
clancy@ltsnet.net

Brenton D. Walker  
brenton@ltsnet.net

Laboratory for Telecommunications Sciences  
US Department of Defense

**Abstract**—Mobile, ad-hoc, wireless networks offer an interesting paradigm for ubiquitous connectivity. They have many proposed applications, and with every application comes new protocols. To test such protocols, one has two basic options: simulators and testbeds. We describe a novel wireless networks testbed called MeshTest, supporting mobile, ad-hoc, and mesh environments, with an emphasis on laboratory testing of large, outdoor environments.

This paper details the testbed design, and derives mathematical relationships between attenuator settings and real-world topologies. We show how to accurately and efficiently map topologies to our testbed configuration in real time, while supporting both device mobility and multipath fading.

## I. INTRODUCTION

Multihop, wireless mesh networks offer an interesting new environment for designers of network protocols. They can also be a very cost-effective mechanism for supporting large, distributed communications, with applications ranging from mobile wireless broadband to sensor networks. However, realistic and repeatable simulation environments are difficult to come by.

Network simulators, such as ns-2 and Opnet, offer repeatability, but it is difficult to quantify their accuracy. Their RF propagation and interference models are based on vast oversimplifications of electromagnetic wave theory. If we cannot be sure how accurate their lower layers are, how can we trust the simulation results for upper-layer protocols?

At the other extreme, one can create testbeds that use *real RF* for experiments. These typically involve many wireless devices in a relatively small area all communicating over the air. This setup too has its shortcomings. In

particular, it can be very difficult to create reproducible, multi-hop networks with such short distances between nodes. Also, testing mobility either involves physically moving devices around the room or using simulation techniques with questionable accuracy.

More accurate wireless test environments require a hybrid between the two. One must be able to reproducibly create arbitrary topologies that more accurately reflect real physics. This can be done by either making more sophisticated simulators or more simulation-like testbeds. We have chosen the latter approach.

We propose MeshTest, an entirely new type of wireless mesh testbed capable of creating much more diverse multi-hop network topologies with complete reproducibility. This is accomplished by putting wireless nodes into RF-shielded enclosures. Antennas are removed and replaced with cables that connect wireless devices to matrix switches. Using these switches, devices can be interconnected with arbitrary attenuation. With Ethernet interfaces, the switches can be reconfigured on the order of milliseconds, changing connections and attenuations.

Section two discusses current wireless testbed research and environments. Section three describes the MeshTest testbed in more detail. Section four presents algorithms for mapping real-world topologies to the MeshTest environment. Section five concludes.

## II. CURRENT WIRELESS TESTBEDS

In the past 10 years, there have been many research endeavors investigating test environments for wireless network protocols. [1] presents a good survey of current research and describes desirable properties for a multi-hop wireless network testbed.

The authors list the following properties that should be evaluated with respect to a wireless testbed:

- **Cost:** the price per node of the wireless testbed should be relatively low for wide-scale deployments.

---

This work was funded by the Laboratory for Telecommunications Sciences, US Department of Defense, and supported by the University of Maryland and Rutgers. The opinions expressed in this paper reflect those of the authors, and do not necessarily represent those of the Department of Defense or US Federal Government.

- **Management:** nodes should be easily managed from a single location via some out-of-band control channel such as an independent Ethernet interface.
- **Resource Sharing:** the testbed should be usable by multiple users simultaneously if enough nodes are available to accommodate their simulations.
- **Experimental Control:** the testbed should allow for the automatic configuration of the experiment topology, applications, node mobility, device configuration, execution, and debugging.
- **Experimental Analysis:** analysis tools should be available to filter, visualize, and extract statistics from collected traces.
- **Applicability:** the testbed should support testing and evaluation of diverse protocol suites, both at the application layers and PHY/MAC layers.
- **Repeatability:** experiment executions should produce repeatable results.

Next, we consider several current testbeds. For a complete analysis of available testbeds see [1].

MIT's RoofNet project [2] was the first testbed to allow realistic testing of large-scale mesh protocols. Rooftops throughout Cambridge, MA have wireless nodes that form a static mesh topology for the purpose of providing wireless broadband service. A similar network geared more for testing of indoor networks, TAP [3], has also been extended to provide wireless broadband access. Both RoofNet and TAP, however, lack the ability to create arbitrary topologies or experiment with mesh node mobility in an automated, reproducible way.

Another class of testbeds emulates large-scale networks in small spaces by regulating radio transmit power and adding attenuation to antennas. These include the EWANT [4], ORBIT [5], and MiNT [6] testbeds. The biggest problem with this approach is that it is very tricky to get transmit power levels set at exactly right to reliably obtain multi-hop topologies. For example, the ORBIT testbed has 400 nodes, but can only create topologies with a diameter of 4 to 6 nodes. Also, unless these testbeds are constructed in shielded, anechoic chambers, multipath interference levels are extremely unrepresentative of large-scale outdoor environments. Additionally, signal reception is not always a function of SNR, but also absolute power. Consequently, testbeds that lower SNR by raising the noise floor of the environment do not necessarily offer correct simulation results.

MeshTest, on the other hand, is able to strictly control multipath interference and attenuation while giving the experimenter complete control over mobility and topology. The major drawback, however, is cost, which may be prohibitively high for many academic research environments.

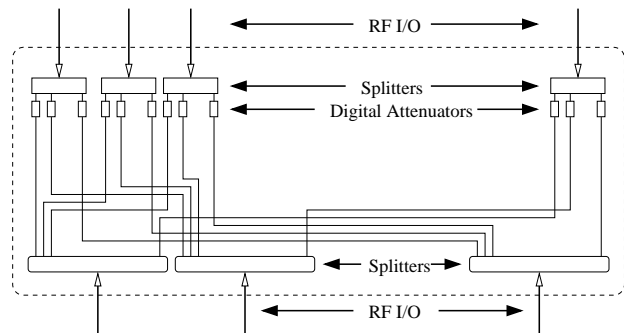

Fig. 1. RF matrix switch diagram, showing  $n$  upper I/O ports,  $b$  lower I/O ports, and  $nb$  Ethernet-controlled digital attenuators with ranges 0-127 dB

### III. MESHTEST TESTBED

MeshTest is an entirely new paradigm in wireless network testbeds. Current testbeds, such as ORBIT, are very well suited to test conventional WiFi-like services. For example, one could easily measure the per-user throughput as a function of the number of active nodes transmitting through a base station. However, mesh networks require much more detailed topology control and flexibility. MeshTest provides this.

#### A. Basic Construction

MeshTest is built in modular racks of 12 computers. Each computer is housed in an RF-shielded enclosure, and has two wireless network interface cards. These cards' antenna connectors are wired to SMA bulkhead connectors. The enclosures themselves offer roughly 80 dB of signal isolation.

Cables are then attached to the SMA outputs that connect them into an RF matrix switch. Figure 1 shows the logical construction of an  $n \times b$  switch. It has  $n$  inputs that connect through  $nb$  digital attenuators to  $b$  buses. Each bus has a direct, unattenuated, external connection.

Figure 2 depicts a 12-node setup that uses a single RF matrix switch. The shielded enclosures also provide filtered Ethernet, USB, and DC power for the devices inside them.

Note that the RF switch only simulates inter-node channel loss, and not propagation times. Propagation delay is simulated by delaying packet transmission and processing times in software at the sender and receiver.

While any device may be placed into the enclosures, ranging from cellular telephones to a software-defined radios, the default configuration involves 802.11-based computers. Through a partnership with Rutgers, nodes from their ORBIT testbed have been acquired.



Fig. 2. Assembly and connection of the shielded enclosures and RF switch.

### B. Simulation Management

In order to be effective, the testbed must be easy to configure, be able to accept scripted simulation scenarios, and be able to measure the outcome. To that end, the testbed utilizes the ORBIT testbed infrastructure. It provides the ability to input a mobile network simulation, much like an ns-2 script.

Reusing ORBIT's management framework allows us to meet many of the testbed requirements, including management, resource sharing, experimental control, and experimental analysis. Applicability and repeatability are addressed through our use of the RF matrix switches.

## IV. TOPOLOGY MAPPING

The first step in any experiment is to configure the testbed with the desired topology. Internode attenuation, as configured through the switch matrices, must be representative of the target environment.

### A. Topology Modeling

Consider an arbitrary network of  $n$  nodes. One can completely represent its topology as a matrix  $L$  of inter-

node attenuations.

$$L = \begin{bmatrix} \ell_{1,1} & \cdots & \ell_{1,n} \\ \vdots & \ell_{i,j} & \vdots \\ \ell_{n,1} & \cdots & \ell_{n,n} \end{bmatrix} \quad (1)$$

Here,  $\ell_{i,j}$  represents the multiplicative attenuation between nodes  $n_i$  and  $n_j$ . For a static network without fading, the values represented in this matrix will be constant, and represent attenuation due to path loss and obstructions.

Mobility and fading significantly complicate the model. In this case, matrix  $L$  will vary as a function of time, and  $L(t)$  will be a random process where each matrix entry  $\ell_{i,j}$  has a log-normal distribution. In particular,

$$10 \log_{10} \ell_{i,j}(t) \sim \mathcal{N}(\mu_{i,j}, \sigma^2) \quad (2)$$

Mobility is simply a further extension of this idea. Now  $E[\ell_{i,j}]$  varies as a function of time. The values correspond to internode attenuations changing as devices move around and the topology changes.

For the purposes of our analysis, let's rewrite  $L(t)$  in terms of a deterministic portion and a stochastic portion. That is,

$$L(t) = L_m(t) .* L_f(t) \quad (3)$$

where  $.*$  is MATLAB notation for entry-wise multiplication of matrices, rather than standard matrix multiplication. Here,  $L_m(t)$  is deterministic and has a time-varying mean representing signal attenuation due to path loss and obstructions, and  $L_f(t)$  is a log-normal stochastic process representing the effects of fading.

For fading coherence time  $t_c$ , the values in  $L_f(t)$  are statistically independent of  $L_f(t+\tau)$ , for all  $\tau > t_c$ . Thus  $L(t)$  is white on time scale  $t_c$ .

### B. Matrix Decomposition

Mapping a physical topology to the MeshTest network is equivalent to solving a constrained optimization problem. Let us assume matrix  $L(t)$  is positive, real, and symmetric, and that  $\ell_{i,i} = 1$ .

Now consider our RF matrix switch. Assume it has  $n$  inputs and  $b$  internal buses. At any particular instant in time, its internal state can be represented as a matrix  $S$  of attenuations, where  $s_{i,j}$  is the attenuation between input  $j$  and bus  $i$ .

$$S = \begin{bmatrix} s_{1,1} & \cdots & s_{1,n} \\ \vdots & s_{i,j} & \vdots \\ s_{b,1} & \cdots & s_{b,n} \end{bmatrix} \quad (4)$$

Let's examine how to find a matrix  $S$  that will give us inter-node attenuations  $L(t_0)$  for a specific time  $t_0$ . First, notice that for  $i \neq j$  we have

$$\ell_{i,j} = \ell_{j,i} = \lambda_{i,j} \sum_{k=1}^b s_{k,i} s_{k,j} \quad (5)$$

We can represent this relationship as

$$L = \Lambda \cdot * S^T S \quad (6)$$

Notice the introduction of matrix  $\Lambda$  with elements  $\lambda_{i,j}$ . These represent insertion losses between two inputs of the RF matrix switch when the tunable attenuators are all set to 0 dB. The values in  $\Lambda$  will depend on the particular construction and attenuation properties of the matrix switch. Our devices have 16 inputs with 4 busses. Each input goes through a 4-way splitter, then the digital attenuator. The busses consist of two 8-way combiners connected with a 2-way combiner. If we assume a standard 2-way splitter has a 3.5 dB insertion loss, the resulting matrix is

$$10 \log_{10} \Lambda = \begin{bmatrix} 24.5 & 38.5 \\ 38.5 & 24.5 \end{bmatrix} - \text{diag}(24.5) \quad (7)$$

In words, this means the insertion loss between a node and itself is zero. Then we define two banks. One bank consists of nodes 1 through 8 while the other is nodes 9 through 16. The insertion loss between any two nodes in the same bank is 24.5 dB, while the attenuation across banks is 38.5.

To find our required attenuations, we must solve (6) for  $S$ . Let

$$L_\Lambda = L \cdot / \Lambda \quad (8)$$

where  $\cdot /$  is again MATLAB notation for element-wise division. Solving for  $S$  then equates to decomposing the rank- $n$  matrix  $L_\Lambda$  into a rank- $b$  matrix  $S$ . Unfortunately, since  $n > b$ , an exact solution is not possible. Our goal is to compute a matrix that *best approximates* the real environment. The basic approach will be to compute an initial decomposition, and then use simulated annealing to optimize this decomposition.

The following sections describe this decomposition in more detail, first for a basic, static scenario, and then for an environment that involves mobility and fading.

### C. Basic Decomposition

Since the initial decomposition is just a starting point, its calculation is fairly simplistic. Assume all entries of  $S_0$  are equal to a single value  $s$ . Then each entry of the product matrix  $S^T S$  equals  $bs^2$ . We want this to be

closest in dB to the average value of  $L_\Lambda$  in dB. This relation can be expressed as

$$10 \log_{10}(bs^2) = \frac{1}{n^2} \text{Sum}(10 \log_{10} L_\Lambda) \quad (9)$$

where for an arbitrary matrix  $M$ ,

$$\text{Sum}(M) = \begin{bmatrix} 1 & 1 & \dots & 1 \end{bmatrix} M \begin{bmatrix} 1 \\ 1 \\ \vdots \\ 1 \end{bmatrix} \quad (10)$$

By manipulating our original relation, we can compute a value  $s$  as follows:

$$s = \frac{1}{\sqrt{b}} 10^{\text{Sum}(\log_{10} L_\Lambda)/2n^2} \quad (11)$$

Using  $S_0$  as our initial state, we perform simulated annealing to search for a global minimizer. In each iteration we randomly perturb entries and then find local minimums for each one independently. The perturbations become smaller with each successive iteration, and we converge to a mean-squared optimal value such that for  $\hat{L}_\Lambda = S^T S$ , we minimize

$$\sum_{i,j} (\log \hat{\ell}_{i,j} - \log \ell_{i,j})^2 \quad (12)$$

An in depth analysis of simulated annealing algorithms is beyond the scope of this paper. See any basic AI textbook for a more detailed explanation [7].

This was implemented in MATLAB, with  $n = 16$ . Transceivers were placed randomly, with uniform distribution, over a square kilometer, and their internode attenuations were computed using simple free-space path loss at 2.4GHz, giving us matrix  $L_\Lambda$ .

The initial decomposition  $S_0$  is computed and simulated annealing is executed. The simulated annealing iterates, computing  $S_i$  from  $S_{i-1}$ . It perturbs entries in  $S_i$ , and evaluates those perturbations with respect to objective function (12).

Two experiments were conducted 50 times each, and their results were averaged. In the first, we set  $b = 4$ , and examined how an error function changed with each simulated annealing iteration. The error function was defined as

$$\bar{\Delta} = \frac{10}{n(n-1)} \sum_{i,j} \left| \log_{10}(\ell_{i,j}/\hat{\ell}_{i,j}) \right| \quad (13)$$

This represents the absolute mean difference in dB between coresponding entries in  $L_\Lambda$  and  $\hat{L}_\Lambda$ . This represents an effort to minimize the average distance between desired attenuation and actual attenuation on a per-link basis, and is similar to an L-1 norm. Figure 3

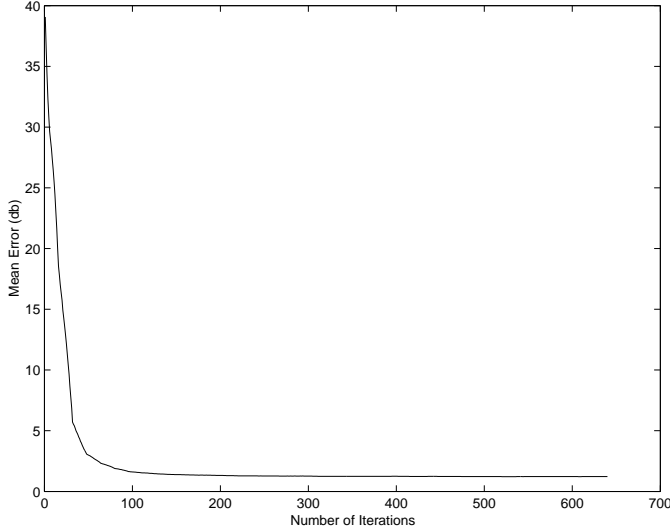

Fig. 3. Plot of  $E[\bar{\Delta}]$  for  $n = 16$  and  $b = 4$ , as a function of the number of simulated annealing iterations, indicating an exponential convergence to an asymptote roughly around 1.2 dB.

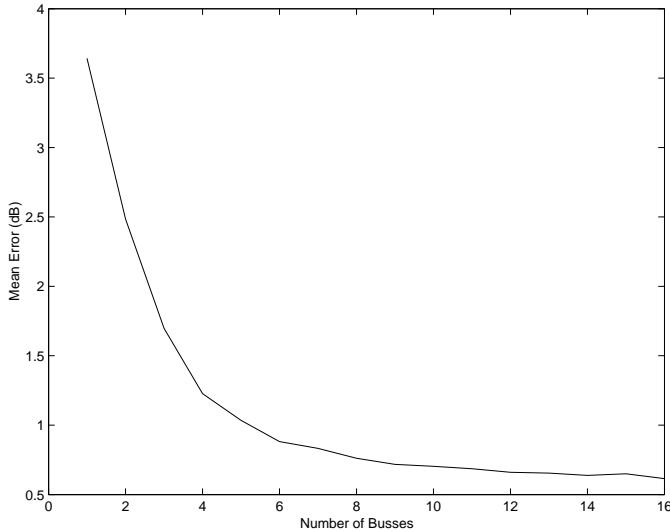

Fig. 4. Plot of  $E[\bar{\Delta}]$  for  $n = 16$ , as a function of  $b$ , indicating an exponential convergence to an asymptote roughly around 0.5 dB.

plots these results, showing very fast convergence to an asymptote.

In the second experiment we varied  $b$  from 1 to  $n$ . This is plotted in figure 4. Regression analysis indicates the curve is  $\mathcal{O}(2^{-b})$ . It's fairly obvious that with more busses you can reach a more accurate solution. Worth mentioning, however, is that for  $n = b$  we should have  $\bar{\Delta} = 0$ , since an exact solution is possible if  $L_\Lambda$  is positive definite. However our simulated annealing fails to find that solution, and achieves one with  $\bar{\Delta} \approx 0.5dB$ .

Our testbed uses  $b = 4$ , and therefore can approximate random topologies to within roughly 1.2 dB of actual

signal path losses. Realize, however, that most real-world inter-device signal attenuations are also affected by obstruction loss and fading. These can be incorporated into the model by constructing an  $L_\Lambda$  based on all these sources, in addition to basic path loss, as is described in the next section.

#### D. Decompositions for Mobility and Fading

In a mobile, fading scenario, we need to be able to rapidly compute new decompositions for our time-varying environment. Let a new decomposition of  $L_\Lambda$  be:

$$L_\Lambda = (SF)^T(SF) \quad (14)$$

where  $S$  is a decomposition of the deterministic portions of  $L_\Lambda$  (i.e. static attenuation caused by path loss and obstructions), and  $F$  represents the stochastic portions (i.e. dynamic attenuation caused by fading). The fading must not induce correlation between independent internode attenuations, and as a result,  $F$  must be a diagonal matrix  $\text{diag}(f_1, \dots, f_n)$ . The resulting decomposition can be expressed as

$$\begin{aligned} (SF)^T(SF) &= FS^T SF \\ &= F\hat{L}_\Lambda F \\ &= \begin{bmatrix} f_1^2 & \cdots & f_1 f_n \\ \vdots & f_i f_j & \vdots \\ f_1 f_n & \cdots & f_n^2 \end{bmatrix} .* \hat{L}_\Lambda \end{aligned} \quad (15)$$

Let  $\hat{F}$  be this new matrix containing pairwise multiplications of  $f_i$ . Thus,

$$(SF)^T(SF) = \hat{F} .* \hat{L}_\Lambda \quad (16)$$

Notice that this is exactly the desired property. Each attenuation is symmetrically affected by a matrix of log-normal random variables. All that remains is to come up with distributions for the  $f_i$  such that the product of two i.i.d. entries,  $f_i f_j$ , yields a log-normal distribution with variance  $\sigma^2$ . This requirement is equivalent to:

$$10 \log_{10} f_i \sim \mathcal{N}(0, \sigma^2/2) \quad (17)$$

or

$$\begin{aligned} f_i &\sim 10^{\mathcal{N}(0, \sigma^2/200)} \\ &\sim e^{\mathcal{N}(0, (\ln^2 10)\sigma^2/200)} \end{aligned} \quad (18)$$

It's also important to look at the correlation of entries in  $\hat{F}$ . The values  $f_i$  represent fading characteristics for node  $n_i$ , and thus the attenuation between  $n_i$  and  $n_j$  is related to the fading characteristics  $f_i$  and  $f_j$ , which is a very intuitive result.

We can compute the correlation more precisely. Let  $f_i$  be distributed as above. Without loss of generality,

consider  $\mathcal{X} = f_1 f_2$ , and  $\mathcal{Y} = f_1 f_3$ . The random variables  $\mathcal{X}$  and  $\mathcal{Y}$  are distributed

$$\mathcal{X}, \mathcal{Y} \sim 10^{\mathcal{N}(0, \sigma^2/100)} \quad (19)$$

The covariance can be computed as

$$\begin{aligned} \text{Cov}[\mathcal{X}, \mathcal{Y}] &= E[(f_1 f_2 - E[f_1 f_2])(f_1 f_3 - E[f_1 f_3])] \\ &= E[f_1^2 f_2 f_3] - \left( e^{(\ln^2 10)\sigma^2/200} \right)^2 \\ &= e^{(3 \ln^2 10)\sigma^2/200} - e^{(\ln^2 10)\sigma^2/100} \end{aligned} \quad (20)$$

From this we can compute the correlation.

$$\begin{aligned} \rho_{\mathcal{X}\mathcal{Y}} &= \frac{\text{Cov}[\mathcal{X}, \mathcal{Y}]}{\sqrt{\text{Var}[\mathcal{X}]\text{Var}[\mathcal{Y}]}} \\ &= \frac{e^{(3 \ln^2 10)\sigma^2/200} - e^{(\ln^2 10)\sigma^2/100}}{e^{(\ln^2 10)\sigma^2/50} - e^{(\ln^2 10)\sigma^2/100}} \\ &= \frac{1}{e^{(\ln^2 10)\sigma^2/200} + 1} \end{aligned} \quad (21)$$

This portion was also simulated. Assuming fading can cause a relative shift in signal power from -5 dB to +5 dB, the following MATLAB code generates a matrix  $F$  with proper statistics:

$$F = \text{diag}(10.^{(\text{randn}(n, 1)/10)})$$

This implies that  $\sigma^2 = 2$  gives good results. The resulting correlation is

$$\rho_{\mathcal{X}\mathcal{Y}} \approx 0.4867 \quad (22)$$

Combining the described algorithms, we achieve an effective mechanism for computing statistics in truly diverse environments. We perform an initial decomposition of  $L_m(t_0)$  based on our starting topology, using the simulated annealing approach. This gives us the matrix  $S(t_0)$ . As  $L_m(t)$  changes with time, we can update  $S(t)$  using simulated annealing. This will require very little computation power, provided we use  $S(t_{i-1})$  as the initial decomposition for computing  $S(t_i)$ .

Fading can then be managed separately. Every  $t_c$  time units a new  $F$  can be generated and multiplied by  $S(t)$  to yield the proper attenuator settings.

## V. CONCLUSION

This paper has described a novel wireless mesh testbed capable of reproducibly simulating, multi-hop, mobile topologies with a fading channel. This type of testbed will be essential for realistically testing network protocols.

In addition to describing the testbed, we detail algorithms for computing the appropriate attenuator settings for our RF matrix switches, a problem which ended

up having a very interesting, linear algebra solution. We've shown through MATLAB implementation that on average our algorithms can model the deterministic portion of our internode attenuation to within 1.2 dB. Considering a typical fade margin is 10 dB, this is a very reasonable margin of error.

Future work will examine improving our simulated annealing implementation, focusing on faster, closer approximations. Some preliminary investigation into further algorithm randomization has decreased the mean error, but increased its variance.

This research presents a fundamental mathematical basis on which our testbed can be constructed, showing the accuracy with which we can model real-world RF environments in a laboratory setting. Physical construction of the testbed is currently complete, and we are currently interfacing the management software. We expect to have interesting results from that in the next 12 months.

## REFERENCES

- [1] P. De, A. Raniwala, S. Sharma, and T. cker Chiueh, "Design considerations for a multihop wireless network testbed," *IEEE Communications Magazine*, 2005.
- [2] B. A. Chambers, "The grid roofnet: A rooftop ad hoc wireless network." MIT Masters Thesis, June 2002.
- [3] R. Karrer, A. Sabharwal, and E. Knightly, "Enabling large-scale wireless broadband: The case for TAPs," ACM Hotnets 2002.
- [4] S. Sanghani, T. X. Brown, S. Bhandare, and S. Doshi, "EWANT: The emulated wireless ad hoc network testbed," IEEE WCNC 2003.
- [5] D. Raychaudhuri, I. Seskar, M. Ott, S. Ganu, K. Ramachandran, H. Kremo, R. Siracusa, H. Liu, and M. Singh, "Overview of the ORBIT radio grid testbed for evaluation of next-generation wireless network protocols," IEEE WCNC 2005.
- [6] P. De, A. Raniwala, S. Sharma, and T. cker Chiueh, "MiNT: A miniaturized network testbed for mobile wireless research," IEEE INFOCOM 2005.
- [7] S. Russell and P. Norvig, *Artificial Intelligence: A Modern Approach*. Prentice Hall, 2002.