

THE PLANAR HAMILTONIAN CIRCUIT PROBLEM IS NP-COMplete*

M. R. GAREY†, D. S. JOHNSON‡ AND R. ENDRE TARJAN‡

Abstract. We consider the problem of determining whether a planar, cubic, triply-connected graph G has a Hamiltonian circuit. We show that this problem is NP-complete. Hence the Hamiltonian circuit problem for this class of graphs, or any larger class containing all such graphs, is probably computationally intractable.

Key words. algorithms, computational complexity, graph theory, Hamiltonian circuit, NP-completeness

1. Introduction. A *Hamiltonian circuit* in a graph¹ is a path which passes through every vertex exactly once and returns to its starting point. Many attempts have been made to characterize the graphs which contain Hamiltonian circuits (see [2, Chap. 10] for a survey). While providing characterizations in various special cases, none of these results has led to an efficient algorithm for identifying such graphs in general. In fact, recent results [5] showing this problem to be "NP-complete" indicate that no simple, computationally-oriented characterization is possible. For this reason, attention has shifted to special cases with more restricted structure for which such a characterization may still be possible. One special case of particular interest is that of planar graphs. In 1880 Tait made a famous conjecture [8] that every cubic, triply-connected, planar graph contains a Hamiltonian circuit. Though this conjecture received considerable attention (if true it would have resolved the "four color conjecture"), it was not until 1946 that Tutte constructed the first counterexample [9]. We shall show that, not only do these highly-restricted planar graphs occasionally fail to contain a Hamiltonian circuit, but it is probably impossible to give an efficient algorithm which distinguishes those that do from those that do not.

2. Proof of result. Our proof of this result is based on the recently developed theory of "NP-complete problems". This class of problems possesses the following important properties:

(A) There is no known polynomial-time algorithm that solves any single problem in the class.

(B) The existence of a polynomial-time algorithm for solving any *particular* problem in the class would imply that *every* problem in the class can be solved with a polynomial-time algorithm.

It is widely believed that no NP-complete problem can be solved with a polynomial-time algorithm and hence that all such problems are inherently

* Received by the editors October 23, 1975.

† Bell Laboratories, Murray Hill, New Jersey 07974.

‡ Computer Science Department, Stanford University, Stanford, California 94305. This research was supported in part by a Miller Research Fellowship at the University of California, Berkeley, National Science Foundation Grant GJ-36473X at Stanford University and Bell Laboratories.

¹ See [2] for any undefined terminology in graph theory.

computationally intractable. Formal introductions to the notion of NP-completeness can be found in [1], [5], [6]. Karp [5] first demonstrated that many well-known combinatorial problems were NP-complete. Others have added to a long and growing list of such problems (see [6] for a recent survey).

In [5] a construction due to Lawler was presented which showed that the Hamiltonian circuit problem for arbitrary graphs is NP-complete. Garey, Johnson and Stockmeyer [4] proved that the Hamiltonian line problem for directed planar graphs is NP-complete. (A Hamiltonian line in a directed graph is a directed path which passes through each vertex exactly once, but need not return to its starting point.) We shall show that the Hamiltonian circuit problem is NP-complete even for graphs G satisfying

- (i) G is planar,
- (ii) G is cubic (each vertex has degree 3),
- (iii) G is triply-connected (deletion of any two vertices leaves the graph connected).

Thus the Hamiltonian circuit problem for these highly restricted graphs seems to be essentially as difficult as that for arbitrary graphs.

The formal technical requirements for a proof of NP-completeness are adequately described in [1, Chap. 10], [5], [6]. For our purposes, the only nontrivial requirement is that we show how a known NP-complete problem can be "transformed" in polynomial time into this restricted Hamiltonian circuit problem. This "known" NP-complete problem will be the satisfiability problem of propositional calculus [3], [5].

Let F be any well-formed formula containing atomic variables and the connectives \wedge (and), \vee (or) and $-$ (not). F is *satisfiable* if there exists some assignment of the values *true* and *false* to the variables which makes F *true* under the standard interpretation of the connectives. We shall show how to construct, in polynomial time, a graph G satisfying (i)-(iii) such that F is satisfiable if and only if G contains a Hamiltonian circuit. By results in [3], [5], it suffices to consider only formulas F in conjunctive normal form with three literals per clause. That is, we may assume that F has the form

$$(p_{11} \vee p_{12} \vee p_{13}) \wedge (p_{21} \vee p_{22} \vee p_{23}) \wedge \cdots \wedge (p_{m1} \vee p_{m2} \vee p_{m3}),$$

where each $(p_{i1} \vee p_{i2} \vee p_{i3})$ is called a *clause* and each p_{ij} , called a *literal*, is either an atomic variable or the negation of an atomic variable. We assume that F contains n atomic variables, denoted x_1, x_2, \dots, x_n .

A number of special graph configurations will be used in our construction and are illustrated in Figs. 1-7. Consider the graph, due to Tutte [9], shown in Fig. 1(a). Any Hamiltonian circuit in a graph G that contains this graph as a vertex-induced subgraph must appear locally as one of the states shown in Fig. 1(b) and thus must use the edge marked A . That is, this subgraph acts like a single degree-3 vertex which has one "specified" edge that is required to be used in any Hamiltonian circuit of G .

We use the graph in Fig. 1 to construct the "exclusive-or" graph shown in Fig. 2(a). Any Hamiltonian circuit in a graph G which contains this graph as a vertex-induced subgraph must appear locally in one of the two states shown in Fig. 2(b). Thus this subgraph acts like two separate edges, one joining v to v' and the

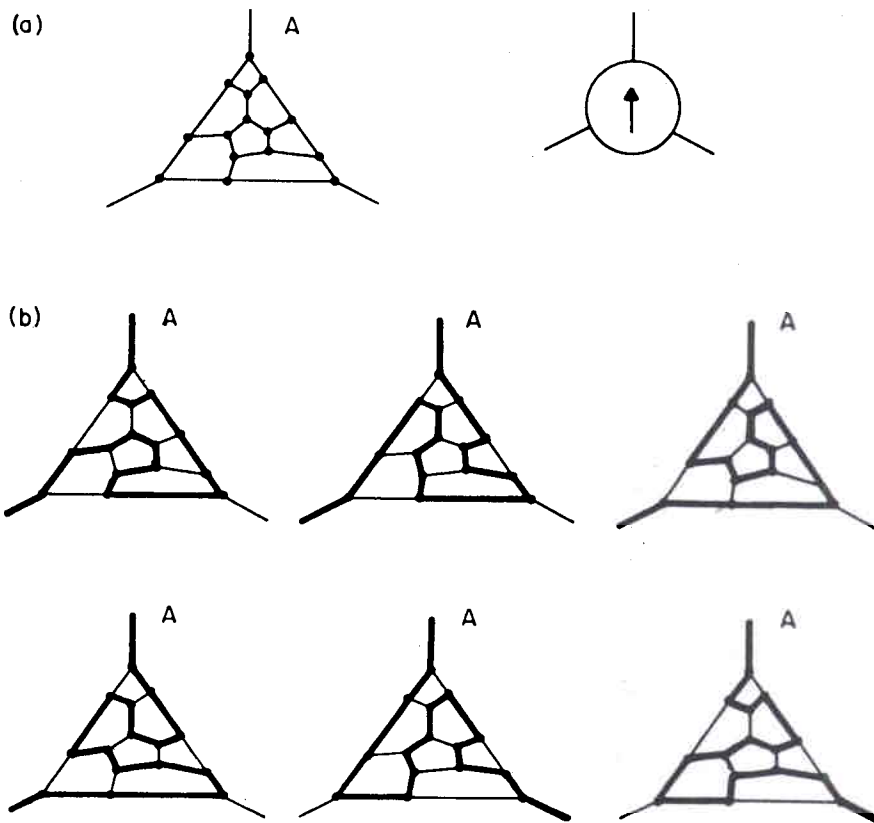

FIG. 1. *Required-edge graph*
 (a) *Graph and abbreviation*
 (b) *Possible local states*

other joining u to u' , with the constraint that exactly one of these two edges must occur in any Hamiltonian circuit of G . In this case, we say that the edges $\{u, u'\}$ and $\{v, v'\}$ have been “joined” by an exclusive-or. Schematically, this will be represented by the abbreviation shown in Fig. 2(a), which we shall call an “exclusive-or line”.

The exclusive-or construction is crucial to the planarity of the graph G which will correspond to the formula F . The key observation is that two “exclusive-or lines” joining different pairs of edges may cross each other without destroying the planarity of G . The property which permits this is that “exclusive-or lines” can be connected in series, as shown in Fig. 3, to cross over an edge of G , when that edge is required to occur in any Hamiltonian circuit. The sequence of two exclusive-or’s pictured there act like a single “exclusive-or line” joining the two outermost edges (B and D) while permitting the required edge (C) to pass between them. In particular, since all 4 vertical edges in an exclusive-or graph must occur in any Hamiltonian circuit, we can use this property to allow two “exclusive-or lines” to

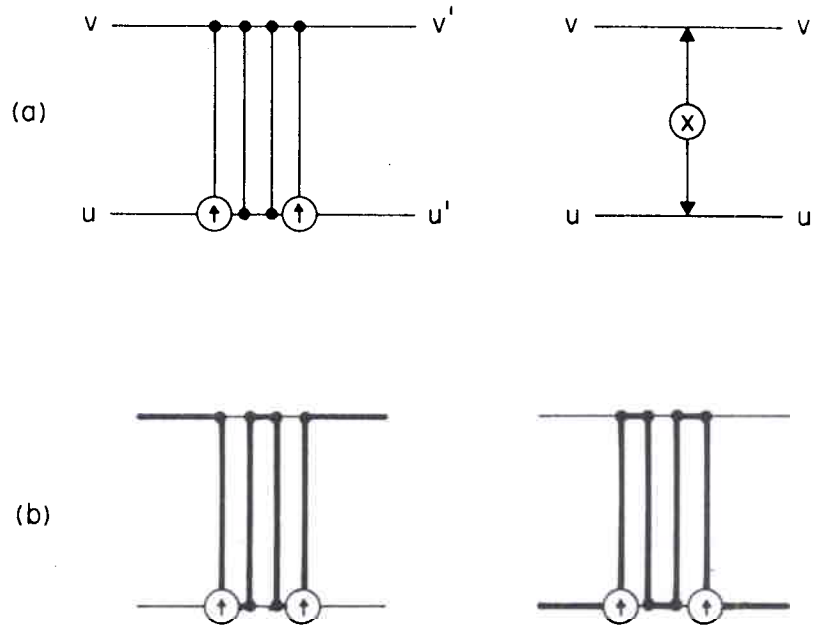

FIG. 2. *Exclusive-or*
 (a) *Graph and abbreviation*
 (b) *Possible local states*

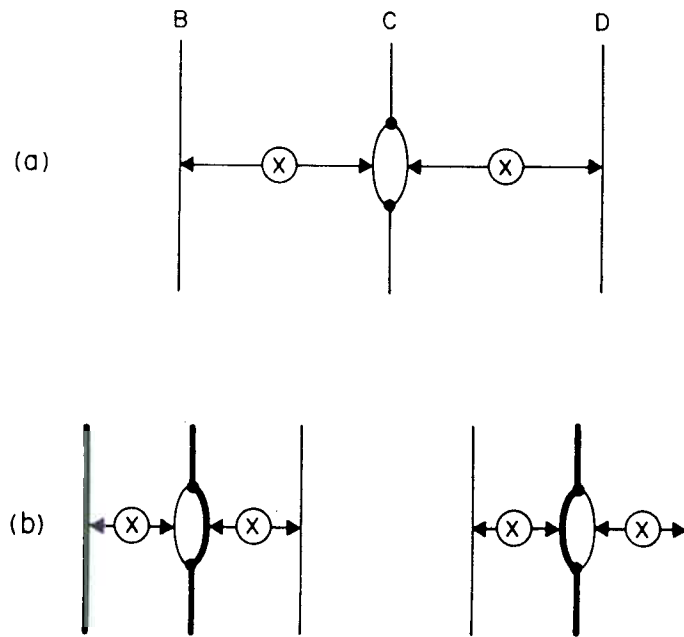

FIG. 3. *Exclusive-or's in series*
 (a) *Schematic of graph*
 (b) *Possible local states*

cross each other. Figure 4 shows schematically how this can be done and illustrates the possible states that can occur in a Hamiltonian circuit.

In addition to the exclusive-or, we will also use the two-input "or" graph of Fig. 5(a). Any Hamiltonian circuit in a graph G which contains this graph as a vertex-induced subgraph must appear locally in one of the states shown in Fig. 5(b). Thus this subgraph acts like two separate edges, one joining v to v' and the other joining u to u' , with the constraint that at least one of these two edges must occur in any Hamiltonian circuit of G .

Finally we use the graphs in Figs. 1, 2 and 5 to construct the three-input "or" shown in Fig. 6. This subgraph acts like three separate edges, one joining v to v' , one joining u to u' , and one joining w to w' , with the constraint that at least one of these three edges must occur in any Hamiltonian circuit of G .

With these components we can undertake the construction. For each of the variables x_i , $1 \leq i \leq n$, we construct four vertices v_{i1}, v_{i2}, v_{i3} and v_{i4} , and for each

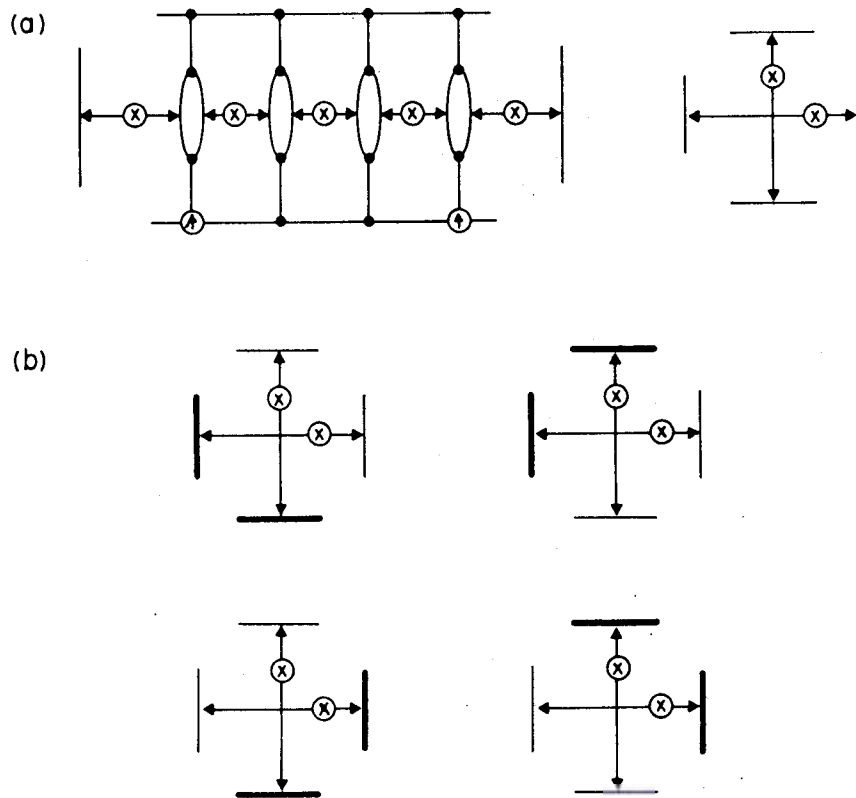

FIG. 4. Crossing of exclusive-or's
 (a) Graph and abbreviation
 (b) Possible local states

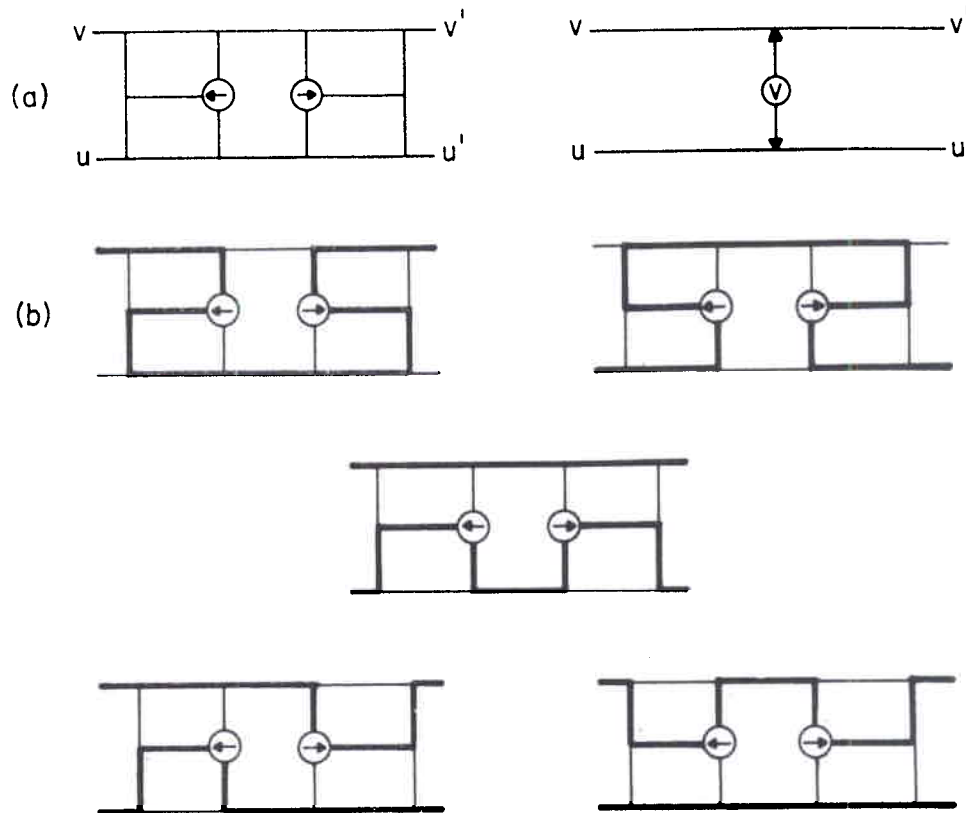

FIG. 5. 2-input or
 (a) Graph and abbreviation
 (b) Possible local states

clause C_j , $1 \leq j \leq m$, we construct six vertices $w_{j1}, w_{j2}, w_{j3}, w_{j4}, w_{j5}, w_{j6}$. We start with the following skeletal edges:

- (a) two copies each of $\{v_{i1}, v_{i2}\}$ and $\{v_{i3}, v_{i4}\}$, $1 \leq i \leq n$;
- (b) $\{v_{i2}, v_{i3}\}$, $1 \leq i \leq n$;
- (c) $\{v_{i4}, v_{i+1,1}\}$, $1 \leq i \leq n - 1$;
- (d) $\{v_{n4}, w_{m6}\}$;
- (e) $\{v_{11}, w_{11}\}$;
- (f) two copies each of $\{w_{j1}, w_{j2}\}$, $\{w_{j3}, w_{j4}\}$ and $\{w_{j5}, w_{j6}\}$, $1 \leq j \leq m$;
- (g) $\{w_{j2}, w_{j3}\}$, $\{w_{j4}, w_{j5}\}$, $1 \leq j \leq m$;
- (h) $\{w_{j6}, w_{j+1,1}\}$, $1 \leq j \leq m - 1$

For each i , we join one copy of $\{v_{i1}, v_{i2}\}$ to one copy of $\{v_{i3}, v_{i4}\}$ with an "exclusive-or". For each j , we connect one copy each of $\{w_{j1}, w_{j2}\}$, $\{w_{j3}, w_{j4}\}$, and $\{w_{j5}, w_{j6}\}$ with a three-input "or". Observe that so far the construction is planar and depends only on the numbers m and n , rather than any more specific details about F .

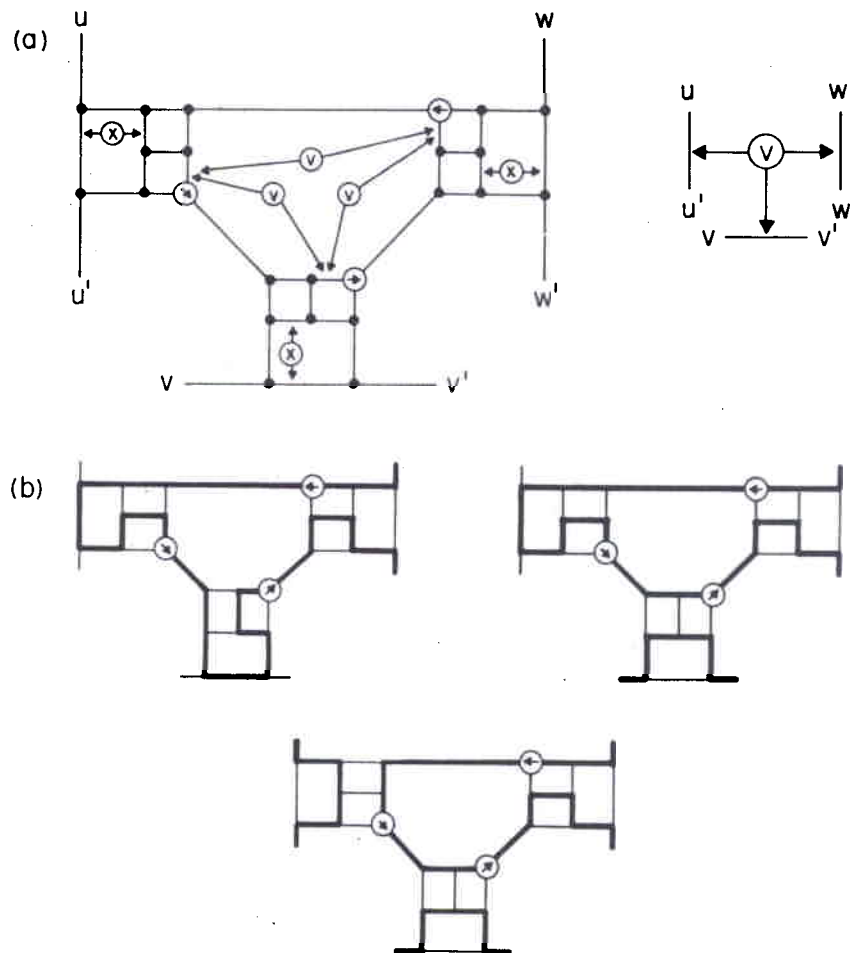

FIG. 6. 3-input or

(a) Graph and abbreviation

(b) Possible local states (symmetric cases not shown)

Now let us consider each literal p_{jk} in F . If $p_{jk} = x_i$, we use an "exclusive-or" to join the copy of $\{w_{j,2k-1}, w_{j,2k}\}$ not connected to a three-input "or" to the copy of $\{v_{i1}, v_{i2}\}$ which is not joined to $\{v_{i3}, v_{i4}\}$ by an "exclusive-or". If $p_{jk} = \bar{x}_i$, we use an "exclusive-or" to join that copy of $\{w_{j,2k-1}, w_{j,2k}\}$ to a copy of $\{v_{i3}, v_{i4}\}$ which is not joined to $\{v_{i1}, v_{i2}\}$ by an "exclusive-or". Finally, we connect $\{v_{i1}, w_{i1}\}$ and $\{v_{i4}, w_{i4}\}$ to a two-input "or". (This is only used to ensure triple-connectedness; both edges in fact must be used in any Hamiltonian circuit of G .) See Fig. 7 for a schematic of this construction for $F = (x \vee y \vee z) \wedge (\bar{x} \vee \bar{y} \vee w) \wedge (y \vee \bar{z} \vee \bar{w})$.

Our constructed graph is planar except for crossing "exclusive-or lines", which are made planar as in Fig. 4. Two "exclusive-or's" need only cross once so

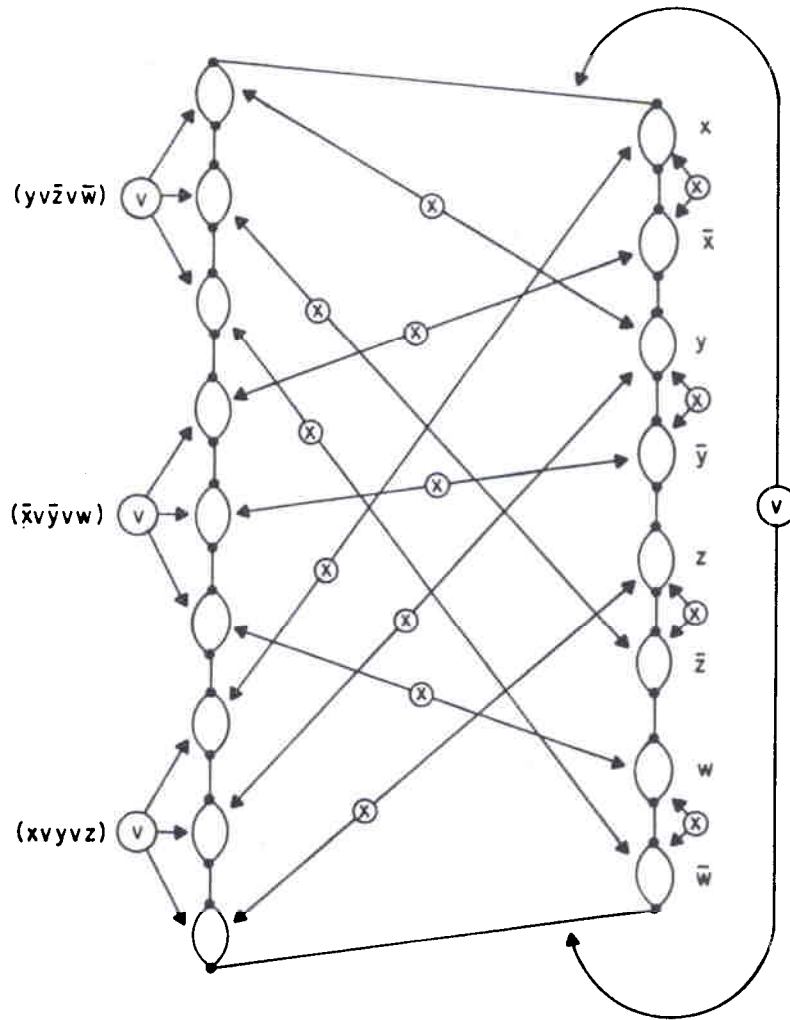

FIG. 7. Complete construction for $F = (x \vee y \vee z) \wedge (\bar{x} \vee \bar{y} \vee w) \wedge (y \vee \bar{z} \vee \bar{w})$

the constructed graph has $O(m^2)$ vertices and edges and is easily constructed in polynomial time.

We leave to the reader the straightforward but tedious verification that the graph is cubic and triply connected. Basically, all one need do is verify that our special subgraphs have these properties (or would if their external edges were connected by external paths) and that the overall superstructure does also (while in addition providing the required "external paths"). Let us now see why the graph as it stands has a Hamiltonian circuit if and only if F is satisfiable.

Consider any Hamiltonian circuit in G . Of each pair of edges $\{v_{i1}, v_{i2}\}, \{v_{i3}, v_{i4}\}$ joined by an "exclusive-or", the circuit must use exactly one. If the circuit uses $\{v_{i1}, v_{i2}\}$ from this pair, we assign x_i the value *false*; otherwise x_i is assigned *true*.

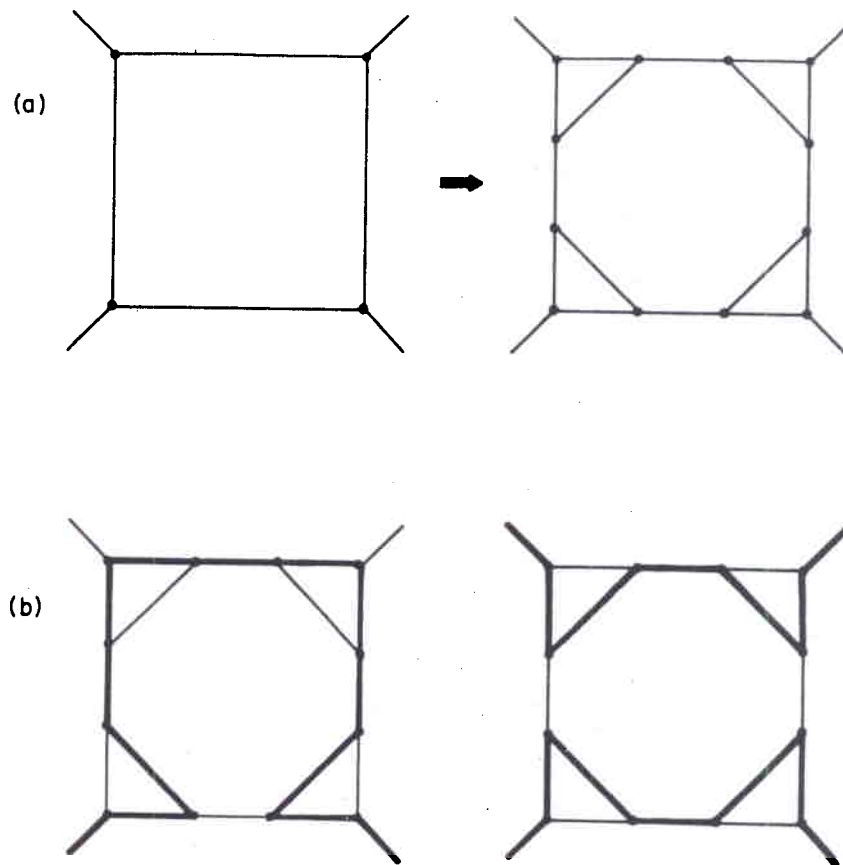

FIG. 8. *Elimination of four-sided face*
 (a) *Substitution graph*
 (b) *Possible local states (symmetric cases not shown)*

The “exclusive-or lines” connecting edges for variables to edges for clauses prevent the clause edges participating in the three-input “or” for that clause from being used unless the corresponding variable makes the clause *true*. Since at least one of those edges *must* be used in any Hamiltonian circuit, it follows that this truth setting must make each clause, and hence F itself, *true*. Similar reasoning shows that any truth assignment satisfying F can be used to construct a Hamiltonian circuit for G . Thus the Hamiltonian circuit problem for graphs satisfying (i)–(iii) is NP-complete.

From our construction, we can also conclude that the three general planar Hamiltonian problems that were left open in [4] are all NP-complete. The undirected planar Hamiltonian circuit problem is NP-complete because it contains our problem as a special case. The directed planar Hamiltonian circuit problem is NP-complete because we can replace every edge $\{u, v\}$ in our construction with two directed edges (u, v) and (v, u) and thus get a directed graph

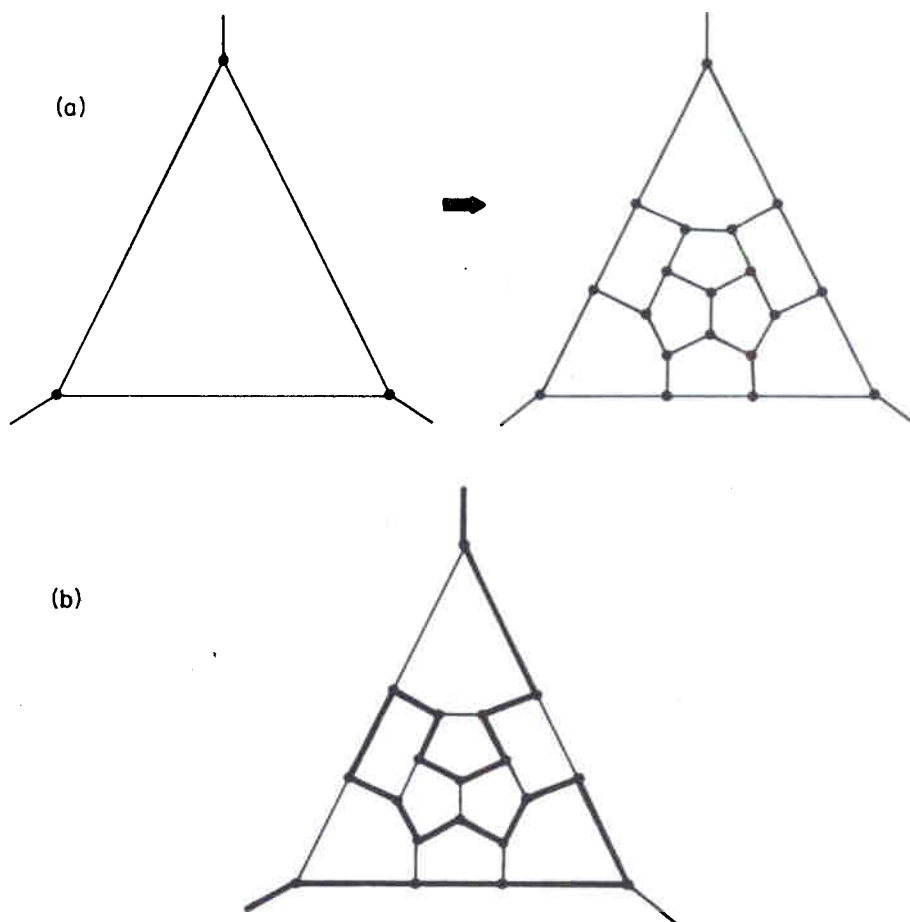

FIG. 9. Elimination of triangle
 (a) Substitution graph
 (b) Possible local state (alternate and symmetric states not shown)

which has a Hamiltonian circuit if and only if our original undirected graph had one. Finally, the undirected planar Hamiltonian line problem is NP-complete: convert the “or” linking edges $\{v_{11}, w_{11}\}$ and $\{v_{n4}, w_{m6}\}$ into an “exclusive or”. A Hamiltonian line must either start at v_{11} and finish at w_{11} , or start at v_{n4} and finish at w_{m6} . Such a line will exist if and only if the original graph had a Hamiltonian circuit. Note that the construction preserves triple connectivity and degree threeness, as well as planarity.

We can also obtain a more specialized result that may be of interest. It has been shown (see [7, Thm. 8.4.1]) that the four color conjecture depends only on graphs in which each face has at least five boundary edges. We can show that the Hamiltonian circuit problem remains NP-complete, even if we restrict ourselves to graphs which have this property and obey (i)–(iii). We do this by taking our

original graph and eliminating its faces with four or fewer sides by making the following substitutions:

If G contains a four-sided face, introduce triangles into each of its four corners as shown in Fig. 8(a). Figure 8(b) illustrates the fact that all the ways that a Hamiltonian circuit might pass through the original face can be mimicked by its replacement, and clearly no new possibilities are introduced. Also, since *two* vertices are introduced into every edge of the original face, no external faces can be made into four-sided faces by this substitution. We further note that the graph remains planar, cubic and three-connected. Repeat the substitution until there are no more four-sided faces.

Triangles are now eliminated in an analogous step by step manner, with the substitution shown in Fig. 9. The result is a graph which is planar, cubic, three connected, has no face with fewer than five sides, and has a Hamiltonian circuit if and only if our original graph did. Since the replacement can clearly be accomplished in time proportional to the number of faces in the original graph, this means that the more restricted problem is also NP-complete.

REFERENCES

- [1] A. V. AHO, J. E. HOPCROFT AND J. D. ULLMAN, *The Design and Analysis of Computer Algorithms*, Addison-Wesley, Reading, Mass., 1974.
- [2] C. BERGE, *Graphs and Hypergraphs*, American Elsevier, New York, 1973.
- [3] S. A. COOK, *The complexity of theorem proving procedures*, Proceedings of Third Annual ACM Symposium, on Theory of Computing, Association for Computing Machinery, New York, 1971, 151-158.
- [4] M. R. GAREY, D. S. JOHNSON AND L. J. STOCKMEYER, *Some simplified NP-complete graph problems*, Theoretical Computer Science, 1 (1976), pp. 237-267.
- [5] R. M. KARP, *Reducibility among combinatorial problems*, Complexity of Computer Computations, R. E. Miller and J. W. Thatcher, eds., Plenum Press, New York, 1972 pp. 85-104.
- [6] ———, *On the computational complexity of combinatorial problems*, Networks, 5 (1975), pp. 45-68.
- [7] O. ORE, *The Four-Color Problem*, Academic Press, New York, 1967.
- [8] P. G. TAIT, *Remarks on the colouring of maps*, Proc. Royal Soc. Edinburgh, 10 (1880), p. 729.
- [9] W. T. TUTTE, *On Hamilton circuits*, J. London Math. Soc. 21 (1946), pp. 98-101.