

# CSMC 412

## Operating Systems Prof. Ashok K Agrawala

Set 17

# File-System Interface

- File Concept
- Access Methods
- Disk and Directory Structure
- File-System Mounting
- File Sharing
- Protection

# Objectives

- To explain the function of file systems
- To describe the interfaces to file systems
- To discuss file-system design tradeoffs, including access methods, file sharing, file locking, and directory structures
- To explore file-system protection

# File Concept

- Contiguous logical address space
  - Records
- Types:
  - Data
    - numeric
    - character
    - binary
  - Program
- Contents defined by file's creator
  - Many types
    - Consider **text file, source file, executable file**

# File Attributes

- **Name** – only information kept in human-readable form
- **Identifier** – unique tag (number) identifies file within file system
- **Type** – needed for systems that support different types
- **Location** – pointer to file location on device
- **Size** – current file size
- **Protection** – controls who can do reading, writing, executing
- **Time, date, and user identification** – data for protection, security, and usage monitoring
- Information about files are kept in the directory structure, which is maintained on the disk
- Many variations, including extended file attributes such as file checksum
- Information kept in the directory structure

# File info Window on Mac OS X

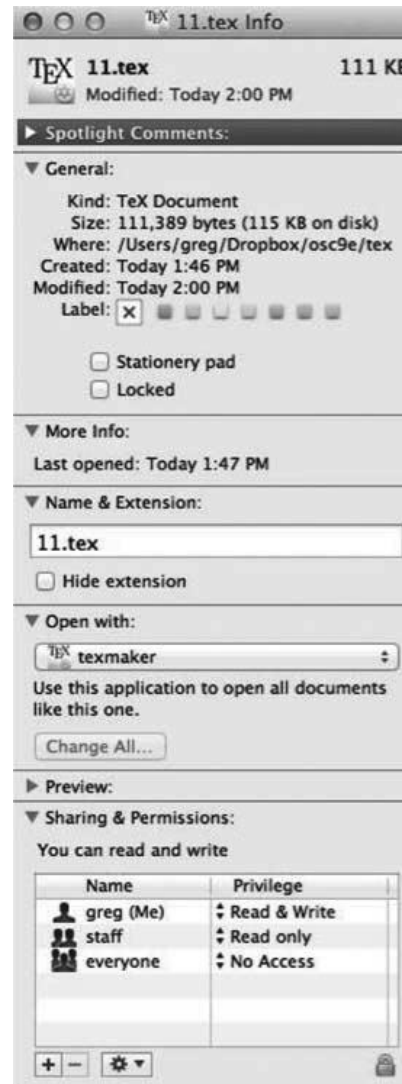

# File Operations

- File is an **abstract data type**
- **Create**
- **Write** – at **write pointer** location
- **Read** – at **read pointer** location
- **Reposition within file - seek**
- **Delete**
- **Truncate**
- **$Open(F_i)$**  – search the directory structure on disk for entry  $F_i$ , and move the content of entry to memory
- **$Close(F_i)$**  – move the content of entry  $F_i$  in memory to directory structure on disk

# Open Files

- Several pieces of data are needed to manage open files:
  - **Open-file table**: tracks open files
  - File pointer: pointer to last read/write location, per process that has the file open
  - **File-open count**: counter of number of times a file is open – to allow removal of data from open-file table when last processes closes it
  - Disk location of the file: cache of data access information
  - Access rights: per-process access mode information



# Open File Locking

- Provided by some operating systems and file systems
  - Similar to reader-writer locks
  - **Shared lock** similar to reader lock – several processes can acquire concurrently
  - **Exclusive lock** similar to writer lock
- Mediates access to a file
- Mandatory or advisory:
  - **Mandatory** – access is denied depending on locks held and requested
  - **Advisory** – processes can find status of locks and decide what to do

# File Locking Example – Java API

```
import java.io.*;
import java.nio.channels.*;
public class LockingExample {
    public static final boolean EXCLUSIVE = false;
    public static final boolean SHARED = true;
    public static void main(String arsg[]) throws IOException {
        FileLock sharedLock = null;
        FileLock exclusiveLock = null;
        try {
            RandomAccessFile raf = new RandomAccessFile("file.txt", "rw");
            // get the channel for the file
            FileChannel ch = raf.getChannel();
            // this locks the first half of the file - exclusive
            exclusiveLock = ch.lock(0, raf.length()/2, EXCLUSIVE);
            /** Now modify the data . . . */
            // release the lock
            exclusiveLock.release();
        }
    }
}
```

## File Locking Example – Java API (Cont.)

```
        // this locks the second half of the file - shared
        sharedLock = ch.lock(raf.length()/2+1, raf.length(),           SHARED);
        /** Now read the data . . . */
        // release the lock
        sharedLock.release();
    } catch (java.io.IOException ioe) {
        System.err.println(ioe);
    }finally {
        if (exclusiveLock != null)
            exclusiveLock.release();
        if (sharedLock != null)
            sharedLock.release();
    }
}
}
```

# File Name

- name used to uniquely identify a computer file stored in a file system.
- Name may include:
  - Host
  - Device
  - Path/Directory/Folder
  - File – base name
  - Type/Extension
  - Version
- Common names:

File Name	Contents
README	Project overview
MANIFEST	List of project files with brief explanations
INSTALL	Installation instructions
Copying	Licensing information
TODO	Wish list for future extensions
NEWS	Documentation on user-visible changes
Changes	Code change summary
configure	Platform configuration script
Makefile	Build specification
Makefile.SH	Shell script producing the above
config.h	Platform configuration definitions
config_h.SH	Shell script producing the above
patchlevel.h	Defines the project release version

# File Types – Name, Extension

file type	usual extension	function
executable	exe, com, bin or none	ready-to-run machine- language program
object	obj, o	compiled, machine language, not linked
source code	c, cc, java, pas, asm, a	source code in various languages
batch	bat, sh	commands to the command interpreter
text	txt, doc	textual data, documents
word processor	wp, tex, rtf, doc	various word-processor formats
library	lib, a, so, dll	libraries of routines for programmers
print or view	ps, pdf, jpg	ASCII or binary file in a format for printing or viewing
archive	arc, zip, tar	related files grouped into one file, sometimes com- pressed, for archiving or storage
multimedia	mpeg, mov, rm, mp3, avi	binary file containing audio or A/V information

# File Structure

- None - sequence of words, bytes
- Simple record structure
  - Lines
  - Fixed length
  - Variable length
- Complex Structures
  - Formatted document
  - Relocatable load file
- Can simulate last two with first method by inserting appropriate control characters
- Who decides:
  - Operating system
  - Program

# Sequential-access File

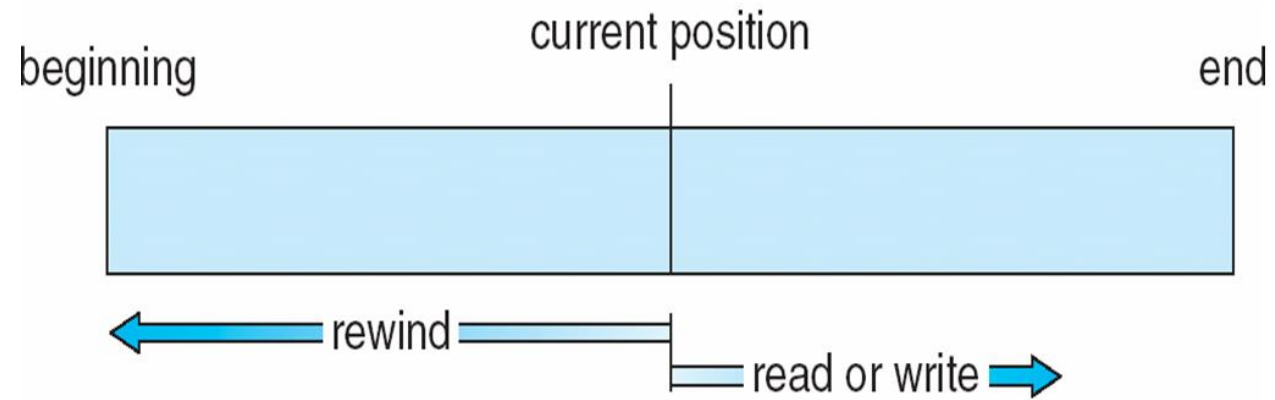

# Access Methods

- **Sequential Access**

```
read next
write next
reset
no read after last write
    (rewrite)
```

- **Direct Access** – file is fixed length **logical records**

```
read n
write n
position to n
    read next
    write next
rewrite n
```

*n* = relative block number

- Relative block numbers allow OS to decide where file should be placed



## Simulation of Sequential Access on Direct-access File

sequential access	implementation for direct access
<i>reset</i>	<i>cp = 0;</i>
<i>read next</i>	<i>read cp;</i> <i>cp = cp + 1;</i>
<i>write next</i>	<i>write cp;</i> <i>cp = cp + 1;</i>

# Other Access Methods

- Can be built on top of base methods
- General involve creation of an **index** for the file
- Keep index in memory for fast determination of location of data to be operated on (consider UPC code plus record of data about that item)
- If too large, index (in memory) of the index (on disk)
- IBM indexed sequential-access method (ISAM)
  - Small master index, points to disk blocks of secondary index
  - File kept sorted on a defined key
  - All done by the OS
- VMS operating system provides index and relative files as another example (see next slide)

# Example of Index and Relative Files

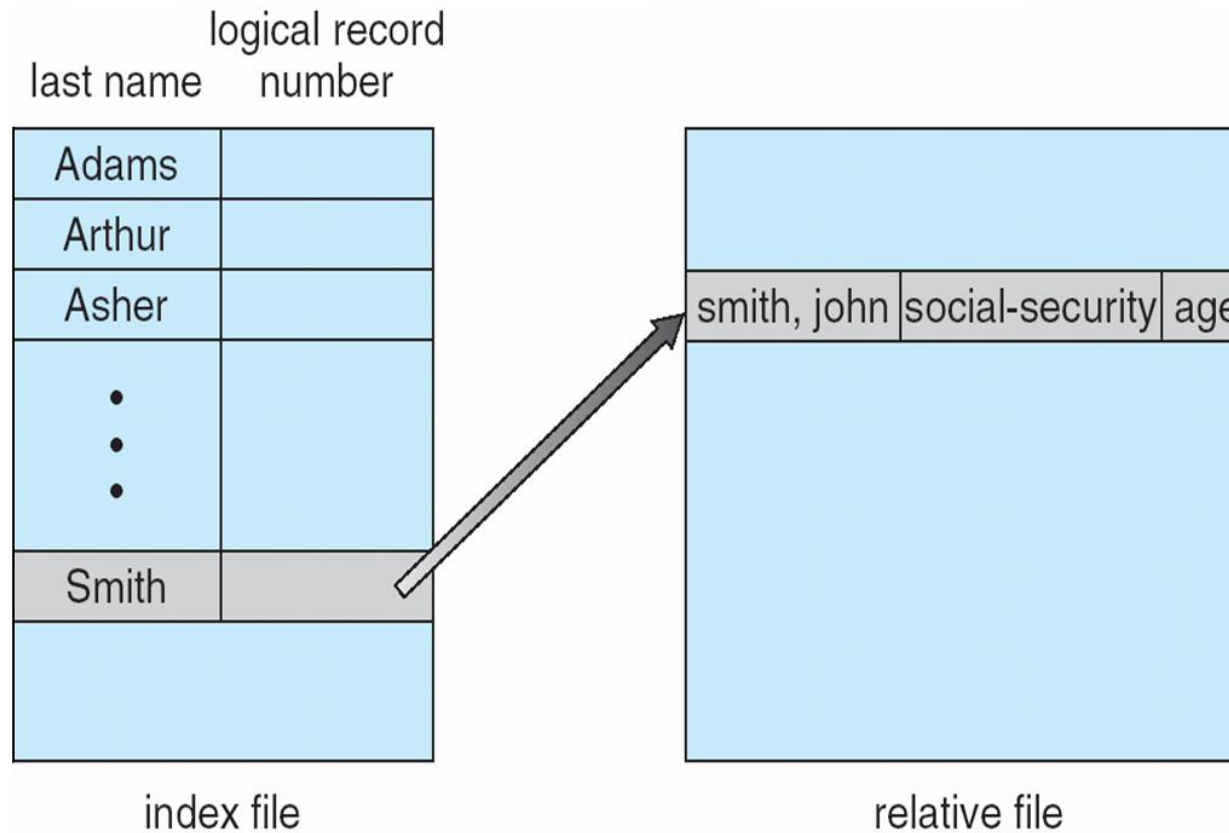

# Directory Structure

- A collection of nodes containing information about all files

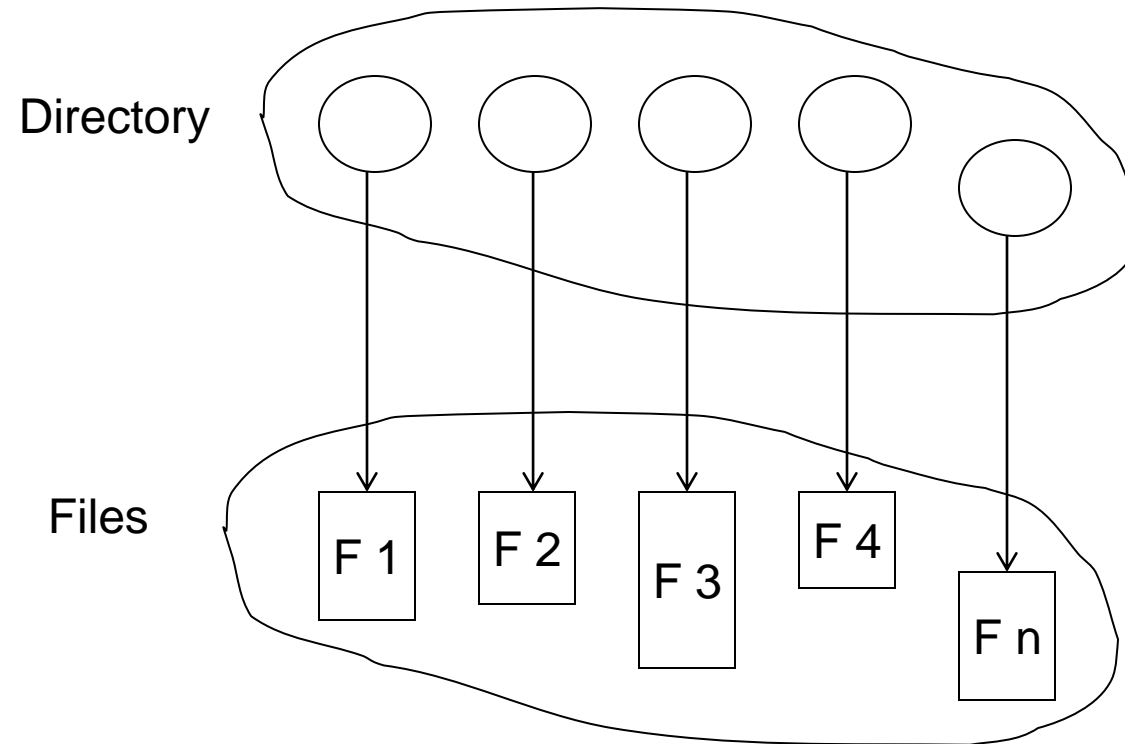

Both the directory structure and the files reside on disk

# Disk Structure

- Disk can be subdivided into **partitions**
- Disks or partitions can be **RAID** protected against failure
- Disk or partition can be used **raw** – without a file system, or **formatted** with a file system
- Partitions also known as minidisks, slices
- Entity containing file system known as a **volume**
- Each volume containing file system also tracks that file system's info in **device directory** or **volume table of contents**
- As well as **general-purpose file systems** there are many **special-purpose file systems**, frequently all within the same operating system or computer

# A Typical File-system Organization

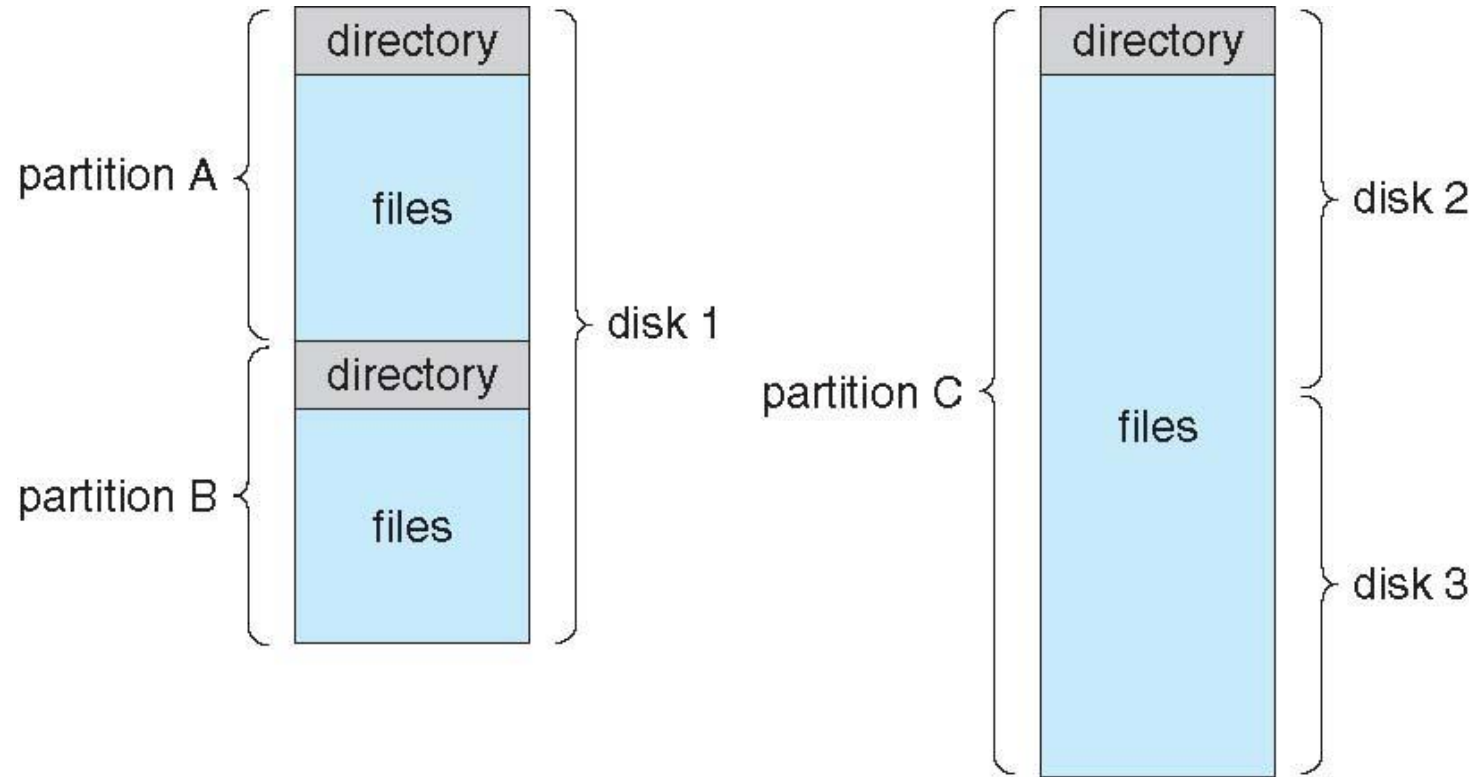

# Types of File Systems

- We mostly talk of general-purpose file systems
- But systems frequently have many file systems, some general- and some special- purpose
- Consider Solaris has
  - tmpfs – memory-based volatile FS for fast, temporary I/O
  - objfs – interface into kernel memory to get kernel symbols for debugging
  - ctfs – contract file system for managing daemons
  - lofs – loopback file system allows one FS to be accessed in place of another
  - procfs – kernel interface to process structures
  - ufs, zfs – general purpose file systems

# Operations Performed on Directory

- Search for a file
- Create a file
- Delete a file
- List a directory
- Rename a file
- Traverse the file system



# Directory Organization

The directory is organized logically to obtain

- Efficiency – locating a file quickly
- Naming – convenient to users
  - Two users can have same name for different files
  - The same file can have several different names
- Grouping – logical grouping of files by properties, (e.g., all Java programs, all games, ...)

# Single-Level Directory

- A single directory for all users

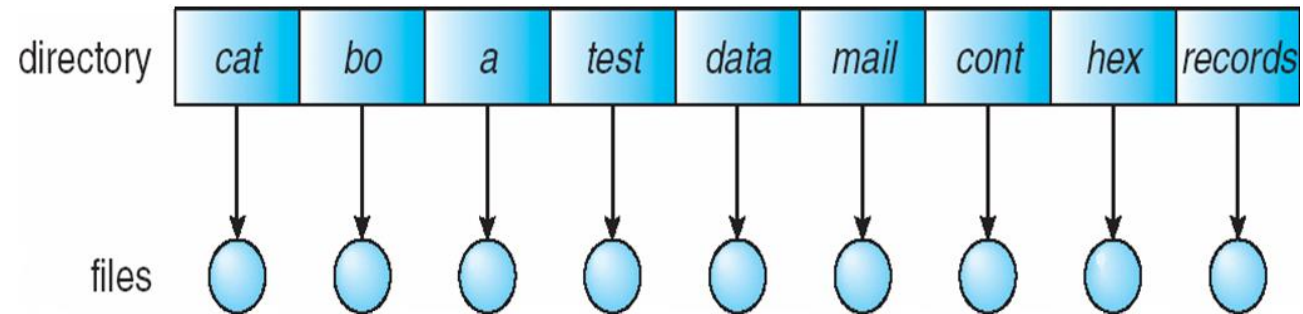

- Naming problem
- Grouping problem

# Two-Level Directory

- Separate directory for each user

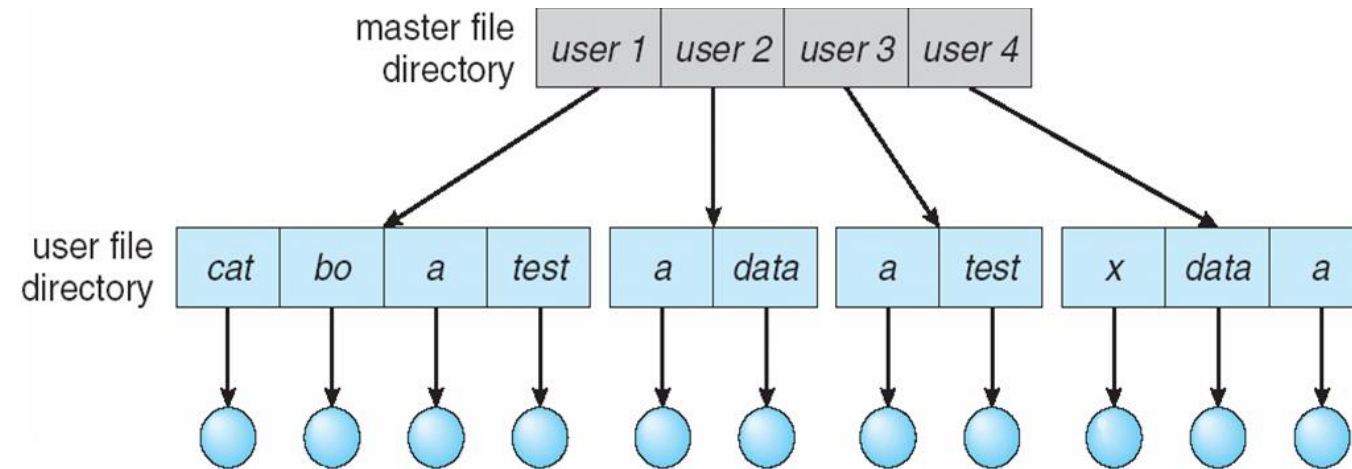

- ❑ Path name
- ❑ Can have the same file name for different user
- ❑ Efficient searching
- ❑ No grouping capability

# Tree-Structured Directories

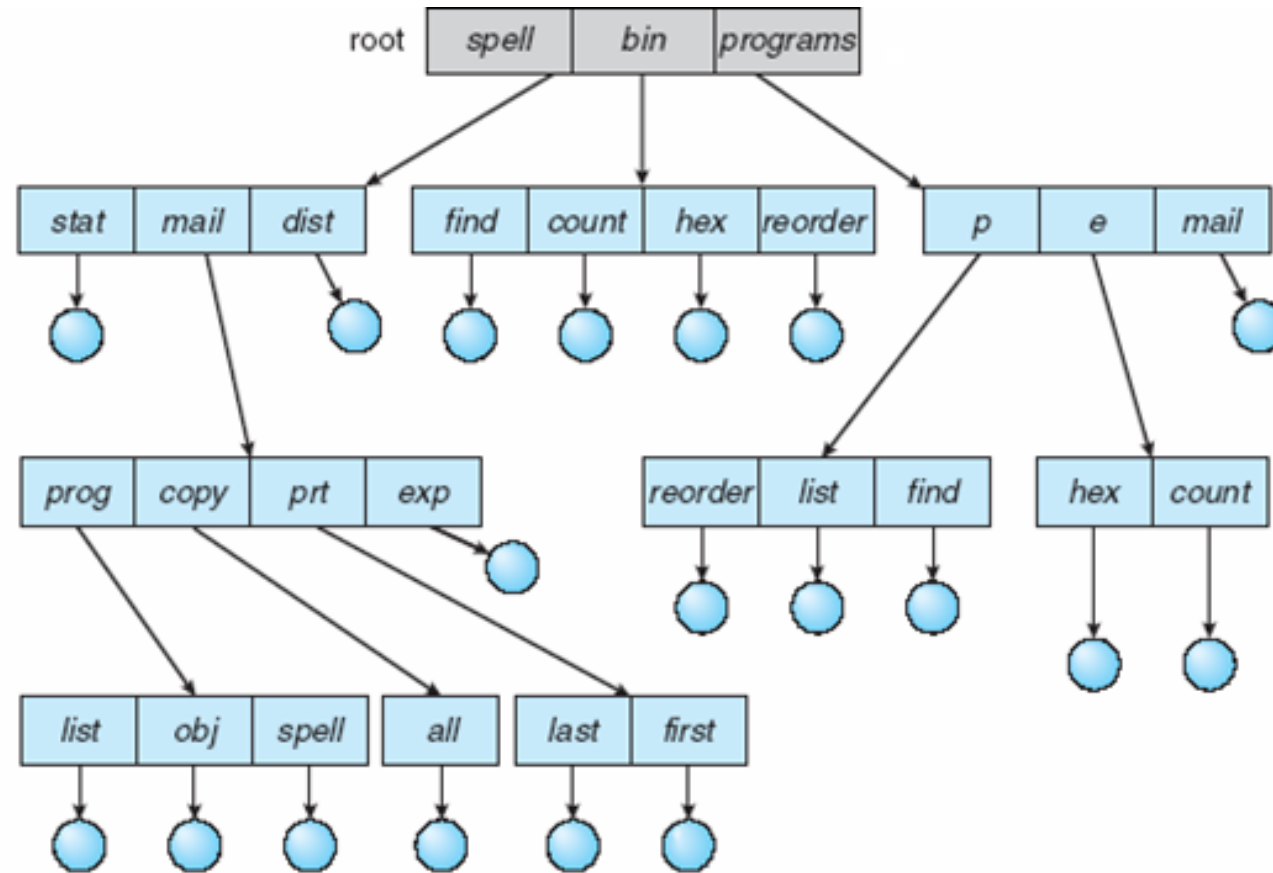

# Tree-Structured Directories (Cont.)

- Efficient searching
- Grouping Capability
- Current directory (working directory)
  - `cd /spell/mail/prog`
  - `type list`

# Tree-Structured Directories (Cont)

- **Absolute** or **relative** path name
- Creating a new file is done in current directory
- Delete a file

**rm <file-name>**

- Creating a new subdirectory is done in current directory

**mkdir <dir-name>**

Example: if in current directory **/mail**

**mkdir count**

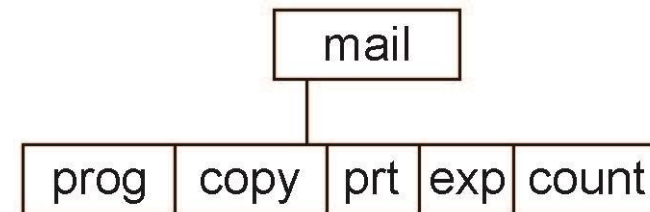

Deleting “mail” ⇒ deleting the entire subtree rooted by “mail”

# Acyclic-Graph Directories

- Have shared subdirectories and files

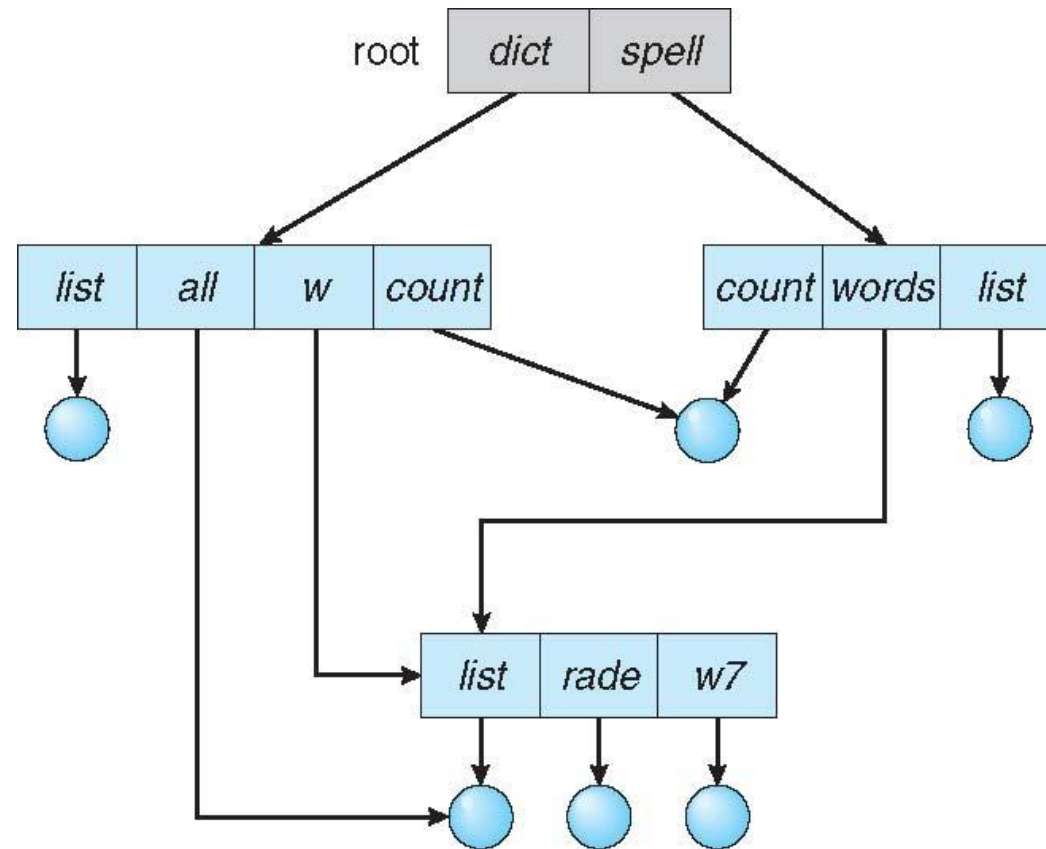

# Acyclic-Graph Directories (Cont.)

- Two different names (aliasing)
- If **dict** deletes **list**  $\Rightarrow$  dangling pointer

## Solutions:

- Backpointers, so we can delete all pointers  
Variable size records a problem
- Backpointers using a daisy chain organization
- Entry-hold-count solution
- New directory entry type
  - **Link** – another name (pointer) to an existing file
  - **Resolve the link** – follow pointer to locate the file



# General Graph Directory

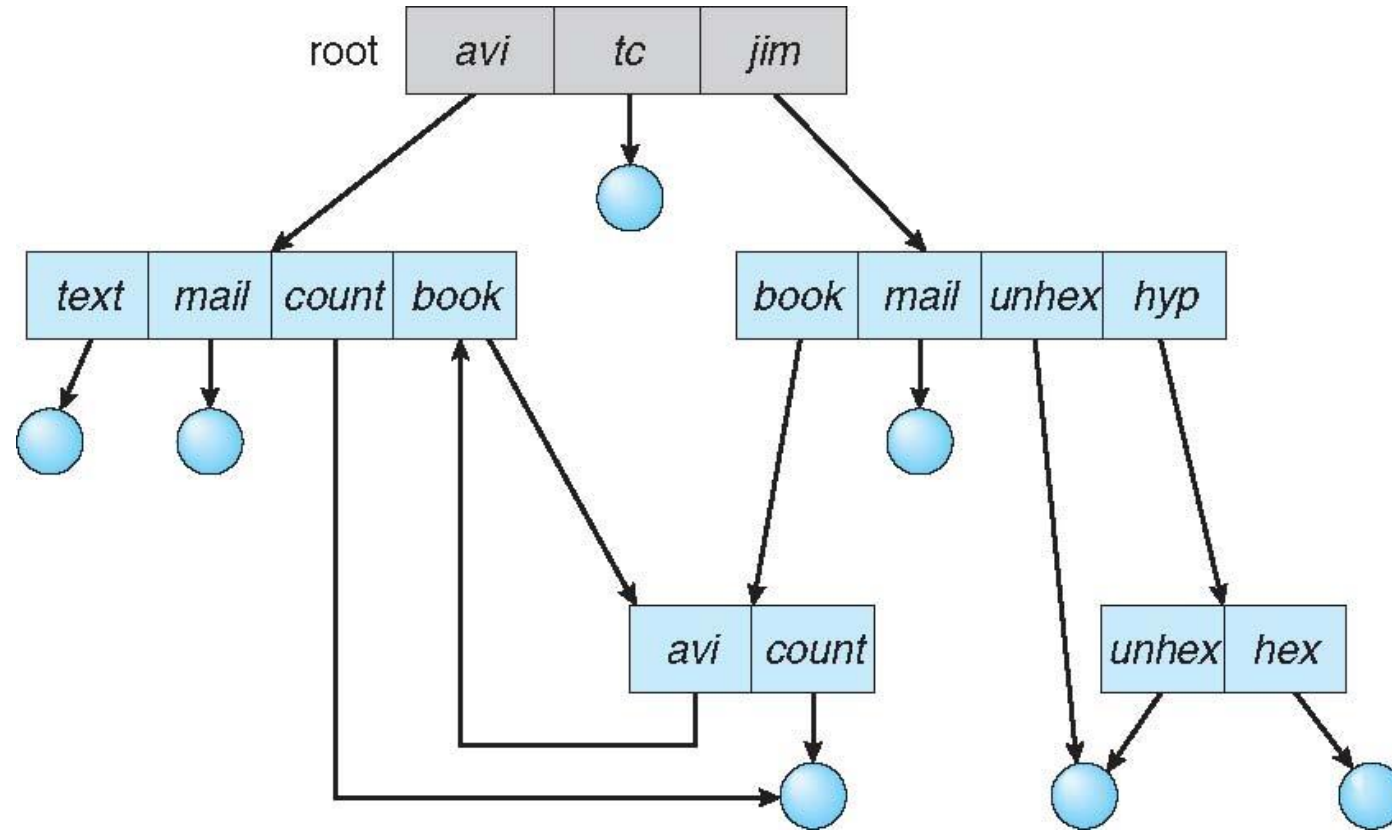

# General Graph Directory (Cont.)

- How do we guarantee no cycles?
  - Allow only links to file not subdirectories
  - **Garbage collection**
  - Every time a new link is added use a cycle detection algorithm to determine whether it is OK

# File System Mounting

- A file system must be **mounted** before it can be accessed
- A unmounted file system is mounted at a **mount point**

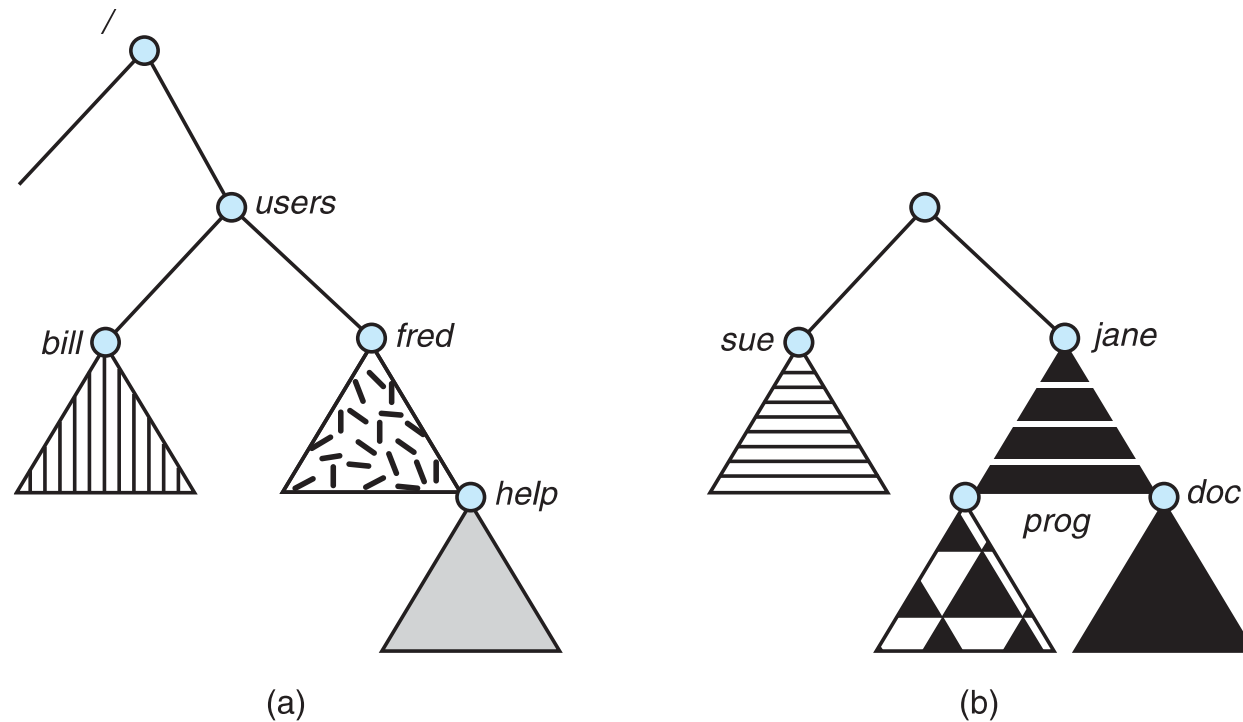

# Mount Point

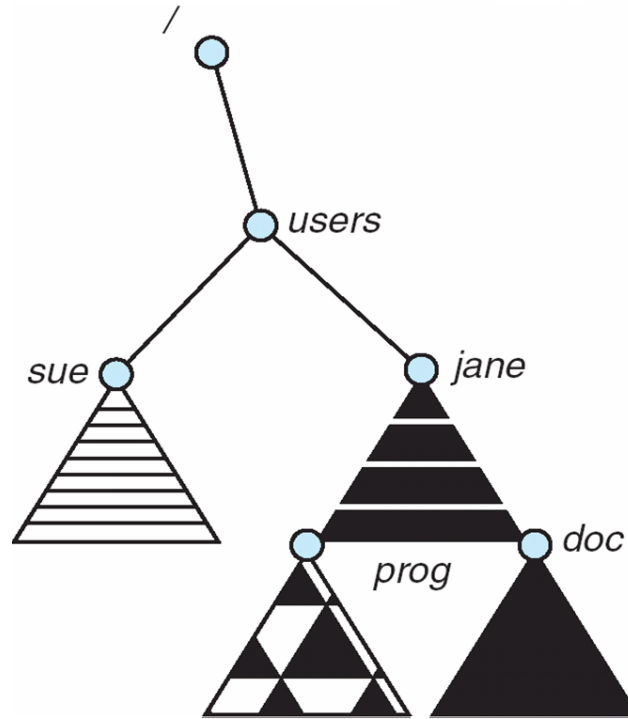

# File Sharing

- Sharing of files on multi-user systems is desirable
- Sharing may be done through a **protection** scheme
- On distributed systems, files may be shared across a network
- Network File System (NFS) is a common distributed file-sharing method
- If multi-user system
  - **User IDs** identify users, allowing permissions and protections to be per-user
  - **Group IDs** allow users to be in groups, permitting group access rights
  - Owner of a file / directory
  - Group of a file / directory

# File Sharing – Remote File Systems

- Uses networking to allow file system access between systems
  - Manually via programs like FTP
  - Automatically, seamlessly using **distributed file systems**
  - Semi automatically via the **world wide web**
- **Client-server** model allows clients to mount remote file systems from servers
  - Server can serve multiple clients
  - Client and user-on-client identification is insecure or complicated
  - **NFS** is standard UNIX client-server file sharing protocol
  - **CIFS** is standard Windows protocol
  - Standard operating system file calls are translated into remote calls
- Distributed Information Systems (**distributed naming services**) such as LDAP, DNS, NIS, Active Directory implement unified access to information needed for remote computing

# File Sharing – Failure Modes

- All file systems have failure modes
  - For example, corruption of directory structures or other non-user data, called **metadata**
- Remote file systems add new failure modes, due to network failure, server failure
- Recovery from failure can involve **state information** about status of each remote request
- **Stateless** protocols such as NFS v3 include all information in each request, allowing easy recovery but less security

# File Sharing – Consistency Semantics

- Specify how multiple users are to access a shared file simultaneously
  - Similar to process synchronization algorithms
    - Tend to be less complex due to disk I/O and network latency (for remote file systems)
  - Andrew File System (AFS) implemented complex remote file sharing semantics
  - Unix file system (UFS) implements:
    - Writes to an open file visible immediately to other users of the same open file
    - Sharing file pointer to allow multiple users to read and write concurrently
  - AFS has session semantics
    - Writes only visible to sessions starting after the file is closed



# Protection

- File owner/creator should be able to control:
  - what can be done
  - by whom
- Types of access
  - **Read**
  - **Write**
  - **Execute**
  - **Append**
  - **Delete**
  - **List**

# Access Lists and Groups

- Mode of access: read, write, execute
- Three classes of users on Unix / Linux

a) owner access	7	⇒	RWX 1 1 1
b) group access	6	⇒	RWX 1 1 0
c) public access	1	⇒	RWX 0 0 1

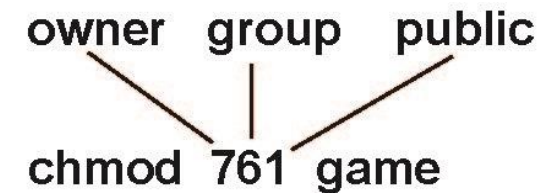

- Ask manager to create a group (unique name), say G, and add some users to the group.
- For a particular file (say *game*) or subdirectory, define an appropriate access.

Attach a group to a file

**chgrp        G        game**

# Windows 7 Access-Control List Management

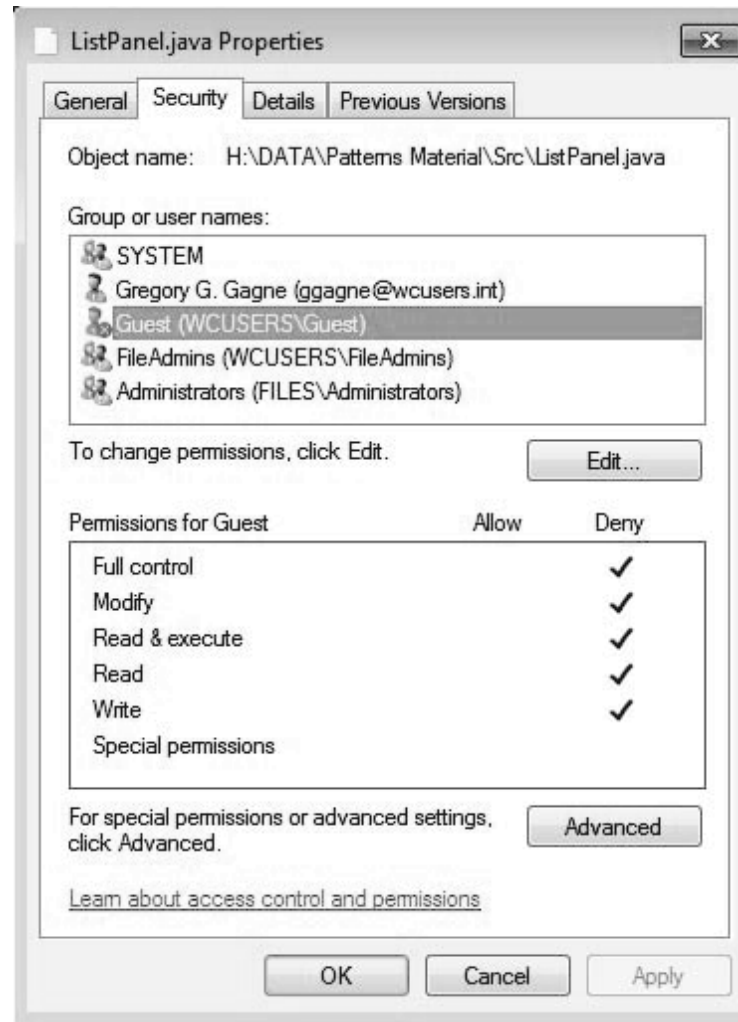

# A Sample UNIX Directory Listing

```
-rw-rw-r-- 1 pbg  staff  31200  Sep 3 08:30  intro.ps
drwx----- 5 pbg  staff    512   Jul 8 09:33  private/
drwxrwxr-x 2 pbg  staff    512   Jul 8 09:35  doc/
drwxrwx--- 2 pbg  student  512   Aug 3 14:13  student-proj/
-rw-r--r-- 1 pbg  staff   9423  Feb 24 2003  program.c
-rwxr-xr-x 1 pbg  staff  20471  Feb 24 2003  program
drwx--x--x 4 pbg  faculty   512   Jul 31 10:31  lib/
drwx----- 3 pbg  staff   1024  Aug 29 06:52  mail/
drwxrwxrwx 3 pbg  staff    512   Jul 8 09:35  test/
```