

CMSC 714
Lecture 21
Finding Idle Cycles
or
High Throughput Computing

Adam Bazinet and Alan
Sussman

Notes

- Send me email about group project presentation day
- Still working on grading midterm exams

Condor

- Developed at the University of Wisconsin-Madison
- Condor is aimed at High Throughput Computing (HTC) on collections of distributively owned resources
- Mainly used to scavenge idle CPU cycles from workstations (typically desktop machines and clusters)

Typical Condor Pool

-----> = Process Spawned
-> = ClassAd Communication Pathway

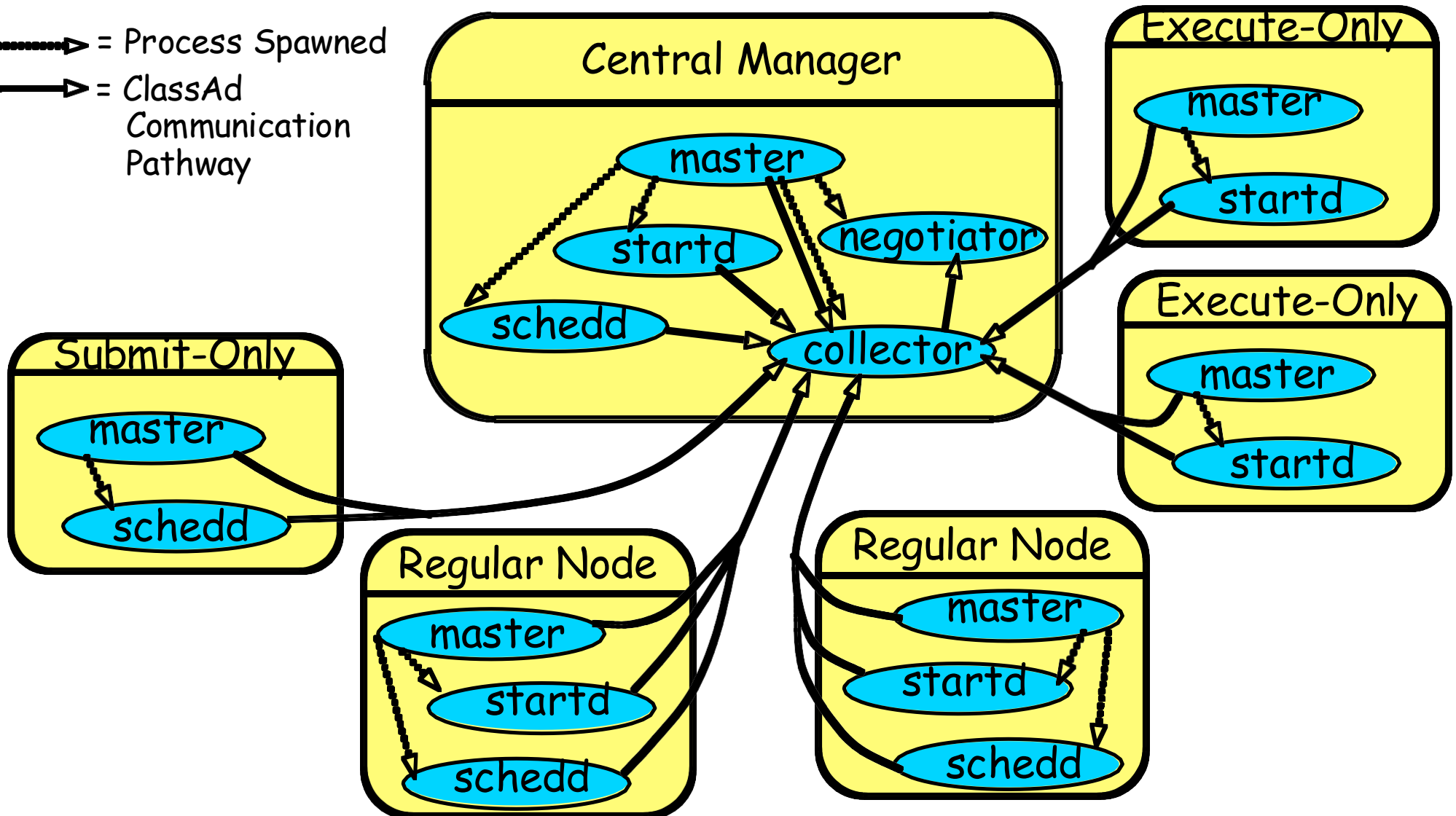

Condor Daemons

- *condor_master* - keeps other daemons running
- *condor_startd* - advertises a given resource
- *condor_starter* - spawns a remote Condor job
- *condor_schedd* - local job scheduler
- *condor_shadow* - coordinates with submitted job
- *condor_collector* - keeps status of Condor pool
- *condor_negotiator* - does all matchmaking

Condor Universes

- Universes are runtime environments for jobs
 - **Standard** universe
 - Provides checkpointing and remote system calls
 - Application must be re-linked with *condor_compile*
 - **Vanilla** universe
 - Instead of with remote system calls, files are accessed with NFS/AFS or explicitly transferred to the executing host
 - Other universes: **PVM, MPI, Globus, Java, Scheduler**

Matchmaking

- Matchmaking is Condor's scheduling mechanism
- Jobs specify their requirements as a list of attributes and values
- Resources advertise their capabilities as a list of attributes and values (ClassAds)
- The *condor_negotiator* matches jobs to resources using these criteria

Condor - A Hunter of Idle Workstations

Previous Work

- In three key areas:
 - The analysis of workstation usage patterns
 - The design of remote capacity allocation algorithms
 - The development of remote execution facilities

Design Goals

- Condor is designed to serve users executing long running background jobs on idle workstations
- Job placement should be transparent
- Job migration should be supported
- Fair access to cycles is expected
- The system should be low overhead

The Scheduling

- At one end: a centralized, static coordinator would handle scheduling
- At the other end: workstations cooperate to conduct a scheduling policy
- In the middle: Condor!

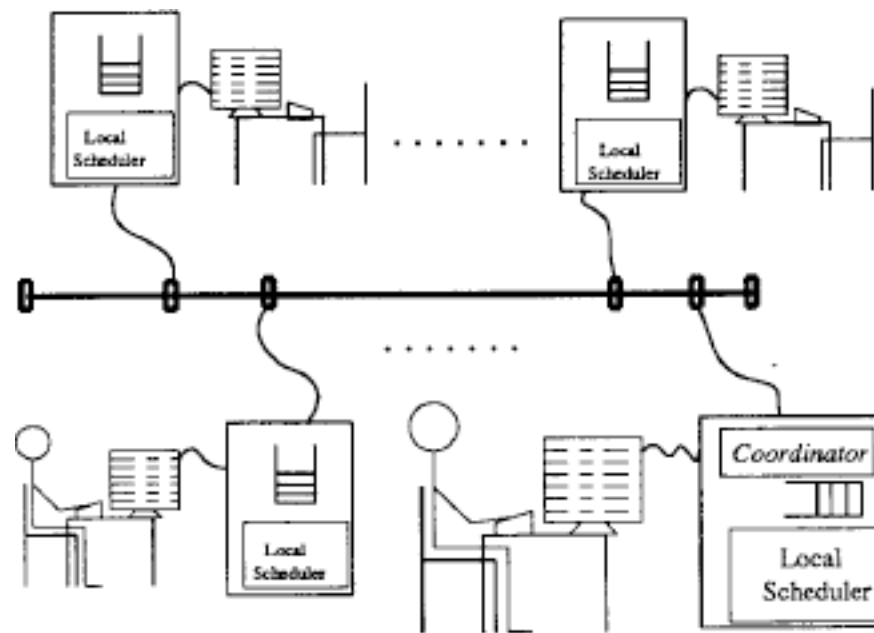

Figure 1: The Condor Scheduling Structure.

Remote Unix (RU) Facility

- Turns idle workstations into cycle servers
- When invoked, a *shadow* process runs locally as the surrogate of the remotely executing process
- System calls go over the network back to the *shadow* (an RPC of sorts)
- Used in the **standard** universe, nowadays

Checkpointing

- When a job is interrupted, RU checkpoints it
 - the state of the program is sent back to submitting machine, and the job may be rescheduled
- Checkpoints consist of the text, data, bss, and stack program segments, registers, status of open files, outstanding messages to the *shadow*, and so on ...
- So to restart the job has to run on on a compatible system

Checkpointing (cont'd)

- Adding checkpointing requires re-linking an application with *condor_compile*, which fattens up the binary a good deal
- Programs now use much more RAM than they did in the past, so checkpointing in the Condor fashion may be problematic in some (many?) cases...

Fair Access to Remote

- By means of the Up-Down algorithm
- In essence, the fewer cycles you burn, the greater your priority over other users of the system... (a dynamic equilibrium)

```
pknut777@leucine:~
> condor_userprio
Last Priority Update: 11/17 23:33

User Name                Effective
-----                -
cerca@umiacs.umd.edu      0.99
austinp@umiacs.umd.edu   69.91
freed@umiacs.umd.edu     143.34
-----                -
Number of users shown: 3
```

Performance Study

- 23 workstations executing Condor jobs were monitored for 1 month
- Study simulated a “heavy” user, and several light users
- Jobs ranged from 30 minutes to 6 hours
- Queue length as high as 40 jobs, for the heavy user

Results

- On average, light users didn't have to wait long for their jobs to run - that's good
- Utilization of remote resources was substantially increased - an additional 200 machine days of capacity were consumed by the Condor system
- Coordinator predicted to be able to manage at least 100 workstations with low overhead

Results (cont'd)

- Average cost of job placement and checkpointing was 2.5 seconds (again, would be higher nowadays)
- On average, all jobs experienced less than one checkpoint per hour
- Remote Unix calls are 20x more expensive than a comparable local call
- A metric called *leverage* is defined as the ratio of remote capacity consumed to local capacity consumed

Conclusions

- The major design goals were achieved!
 - Job placement is transparent
 - Job migration is supported
 - Fair access to cycles is granted
 - The system is low overhead

Condor Today

- Condor has been extremely successful
- It is used by a variety of organizations: large corporations, small businesses, and of course, academic institutions
- At least one company formed to provide Condor support: www.cyclecomputing.com
- And now it is called HTCondor

Top Five Myths About

- **Myth:** Condor requires users to recompile their applications.
- **Reality:** Condor runs ordinary, unmodified applications.
- **Myth:** Condor has a single point of failure.
- **Reality:** Condor has excellent failure isolation.
- **Myth:** Condor is only good at "cycle stealing."
- **Reality:** Condor can effectively manage many kinds of distributed systems.
- **Myth:** Condor only runs sequential jobs.
- **Reality:** Condor has extensive support for parallel programming environments.

Designing a Runtime System for Volunteer Computing

David P. Anderson, Carl Christensen, Bruce

BOINC

- BOINC - Berkeley Open Infrastructure for Network Computing
- A platform for volunteer computing
- Popular in the scientific community
- Well established projects include SETI@home, Folding@home, LHC@home, and about 30 others currently

Design Goals

- To attract and retain volunteers
- To handle widely varying applications
- Support for application debugging
- Support for all popular platforms

BOINC Server

- One per project
- Hands out work to clients
- Keeps track of work to be done for a specific application, available hosts, state of jobs currently running, and where output files end up – all in an RDBMS
- Uses lots of threads to keep everything going w/o much overhead
- Uses *adaptive replication* to make sure all jobs get done in a timely way, even with unreliable clients

BOINC Runtime System

- Consists of an **application**, the **core client**, the **BOINC manager**, and an optional **BOINC screensaver**

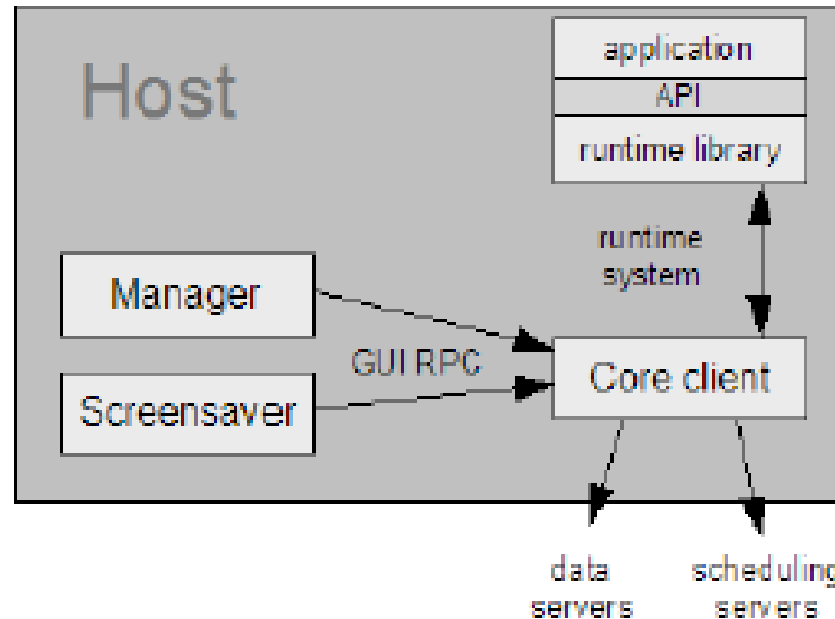

BOINC Core Client (CC)

- Can be run as a standalone command line program, or as a service
- Responsible for scheduling applications
- Also checks resource consumption of the running application
- BOINC runtime library allows application to interact with core client

Architecture: Shared

- For each application, the CC creates a shared memory segment containing a number of unidirectional message channels

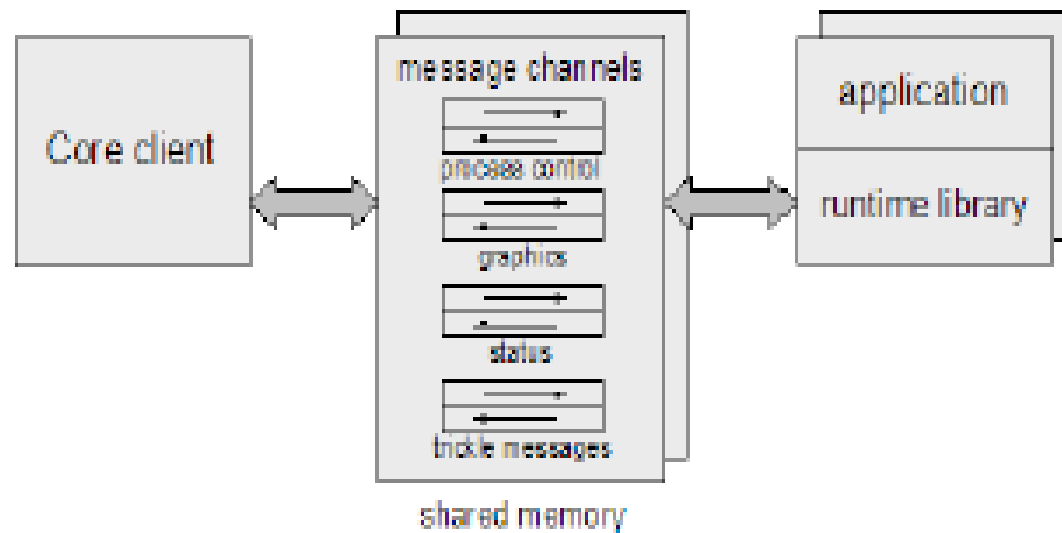

Architecture: Application Thread Structure

- Applications are threaded (pthreads on UNIX, native threads on Windows)

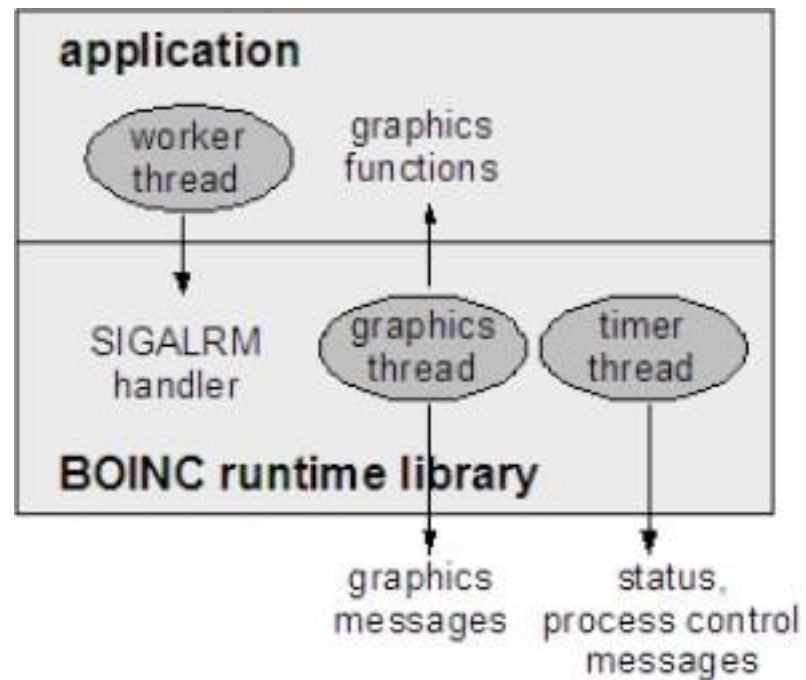

Compound

- Consists of several programs - typically a coordinator that executes one or more worker programs (so a workflow)

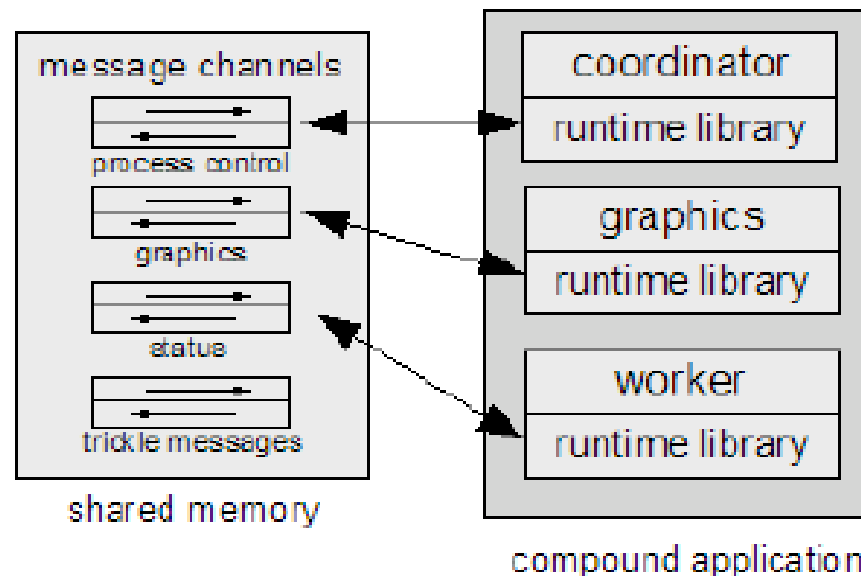

Task Control

- CC can perform various operations on running tasks: **suspend**, **resume**, **quit**, **abort**
- These operations are implemented by sending messages to the process control channel

Status Reporting

- CC needs to know the CPU time and memory usage of each application every second (or so)
- The BOINC runtime library makes the measurements and reports them through the status channel

Credit Reporting

- By default, credit is computed by multiplying a benchmark score by the application's total CPU time
- However, for a number of reasons, this estimate can be erroneous
- Hence, there is support in the BOINC API for allowing the application to directly compute floating point operations

Directory Structure and File Access

- BOINC must run tasks in separate directories, but want to avoid making unnecessary copies of data
 - `boinc_resolve_filename("infile", physical_name);`
 - `f = boinc_fopen(physical_name, "r");`

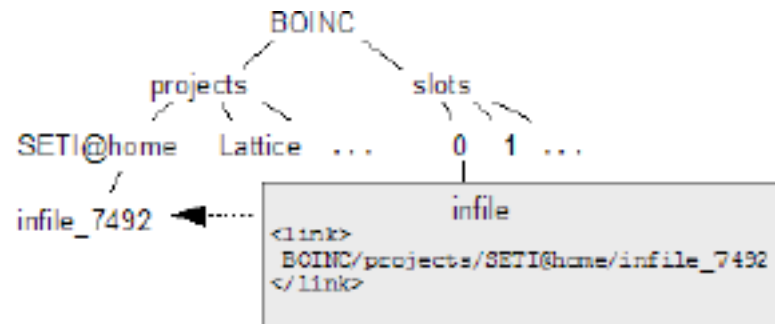

Checkpointing

- Not absolutely necessary, but extremely helpful when trying to get long-running results back, or when a reliable turnaround time is desired
- Checkpointing scheme is application specific! Unlike the Condor mechanism...
- BOINC users care about checkpointing immensely (and will harass you indefinitely until you implement it)

Graphics

- Applications supplied graphics are viewable either as a screensaver or in a window
- BOINC runtime library limits the fraction of CPU time used by the graphics thread

Remote Diagnostics

- Application's standard error is directed to a file and returned to the server for all tasks
- If an application crashes or is aborted, a stack trace is written to standard error
- Problems may occur only with specific OSes, architectures, library versions, etc.

Long-running

- Some projects run tasks that take an extremely long time to complete
- Besides checkpointing, other mechanisms are necessary to support these tasks - for example, periodically granting users credit, or communicating intermediate results to the server for processing
- These mechanisms use the trickle messages channel

Conclusions

- BOINC is very flexible - it satisfies those who want it to stay out of the way completely, as well as those who really want to be involved in the science
- BOINC supports a wide range of applications and runs on every major platform
- Current version includes using GPUs and multicore machines (and runs multithreaded applications)